



BA-C

Air clean up supply series BA

Version BA-C

Special Features

- **High degree of purity:**
 $C_n H_m < 0,1 \text{ ppm}$,
 $H_2O \text{ dew point} < -100 \text{ }^\circ\text{F}$
 $CO_2 < 2 \text{ ppm}$
- **Long service life**
- **Minimum operating costs**
- **Status self-monitoring**
- **Compact, easy-to-use and easy-to-service 19 inch plug-in or wall mounting housing**
- **Safe handling and easy servicing**

Application

Dilution extractive technology requires a constant low dew point clean air supply that removes the concentrations well below the lower detection limits (LDL) of the analyzers used. This translates to low ppb concentrations in some cases.

With ever decreasing concentrations of measured pollutants, an increased purity specification is required to maintain system repeatability since simply changing dilution ratios can cause serious complications

The air clean up supply BA-C has been developed in order to achieve proper dilution air for gas sample dilution probes (see data sheet 2-1.1.7), independent of gas cylinders.

The BA-C unit can also be used as a zero gas generator when calibrating I.R.-analysers for immission monitoring and for hydrocarbon free burner air when measuring hydrocarbons with a FID, FTIR and gas Chromatography also need an ultra-pure reference as well as carrier air supplies.

Description

The M&C-air clean up supply version BA-C has been designed as compact, easy-to-use and easy-to-service 19 inch and wall mounting module.

With version BA-C compressed air is taken via the rear-mounted air filter and is directed to particle and condensate separation by means of a high-performance filter (0.01 micron of filter fineness) with an integrated, floating condensate drainer.

There upon the compressed air is cleaned as a result of low power catalytic oxidation by means of a platinum/palladium catalyst of hydrocarbon traces



Drying the condensate-free compressed air to $< -100 \text{ }^\circ\text{F}$ dew point and removing NO_x and CO_2 takes place in two mol sieve columns.

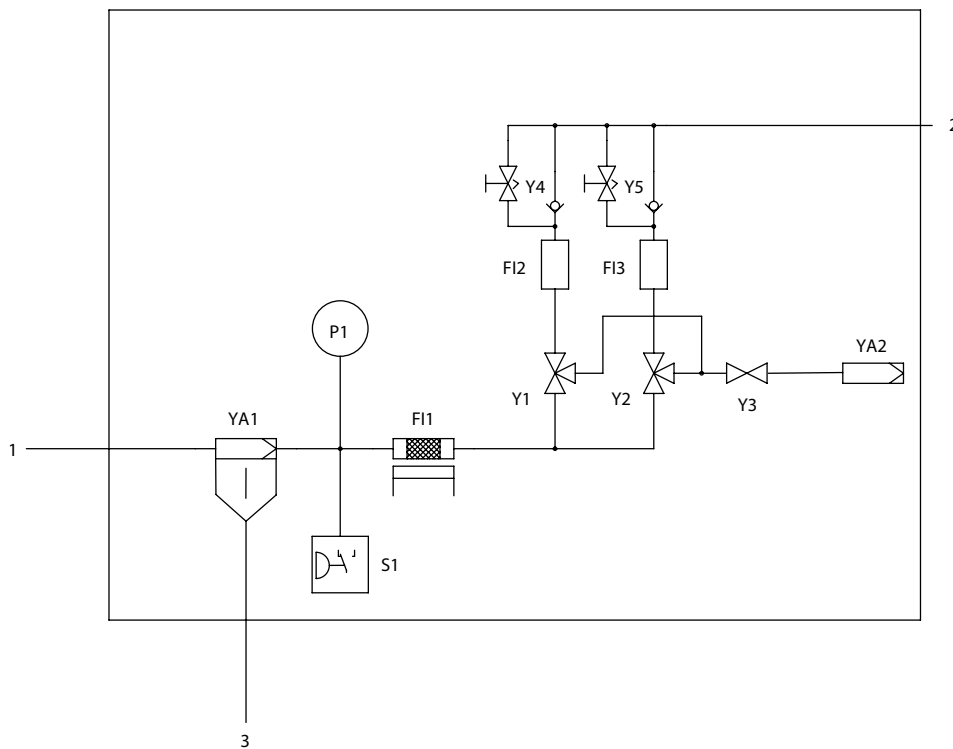

- 1** Air inlet
- 2** Zero air outlet
- 3** Condensate outlet

- F1** Oxidizer
- F2** Mol sieve column
- F3** Mol sieve column

- P1** Pressure gauge
- S1** Pressure switch

- Y1** Solenoid valve
- Y2** Solenoid valve
- Y3** Solenoid valve
- Y4** Check/Needle valve
- Y5** Check/Needle valve

- YA1** Air filter with condensate drainer
- YA2** Sound absorber

Technical data

Air clean up supply series BA	version BA-C
Part No.	60A3000A
Flow (lpm)	max. 12
Instrument air inlet pressure (psig)	70 - 145
Ambient temperature	+41 °F to +104 °F
Start up time	approx. 5 min.
Air purity	Total hydrocarbon content < 0,1 ppm C _n H _m
CO ₂ - concentration	< 2 ppm
Dewpoint	< -100 °F
Catalyst poisons	Halogens, silicon, lead, materials containing phosphorous
Storage temperature	-13 °F to +149 °F
Relative humidity	<75 %, avoid condensation
Inlet gas connection	compressed air in G1/4"i
Outlet gas connections	G 1/4"i
Condensate connection	G1/4"i
Power supply	115V 60Hz 150W
Status signal contact for pressure and temperature	1 contact - potential free, contact rating 24V, 1A
Case protection	IP 20 EN60529
Wall mounting or 19"- housing dimensions (in)	6" x 19" x 10" (H x W x D)
Weight (lbs)	approx. 46
Electrical equipment standard	EN 61010

Notes:

- 1) Exceeds 40 CFR 72.2, 40 CFR 75 Appendix H and the Acid Rain Program CEMS Field Audit Program Manual zero grade air material requirements.
- 2) Custom configuration and higher purity specification are available on request.