

Product Group Condensate Removal.

Product Category Gas Conditioning.





AD-P

Automatic Condensate Float Trap

Versions AD-P, AD-T, AD-So

Separator with Automatic Condensate Float Trap

Versions ADS-P, ADS-T, ADS-So

Special Features

- Safe condensate draining and separation
- Optical function control
- Easy and rapid cleaning
- Different materials available

Application

The M&C condensate float traps AD are used in gas conditioning systems to automatically drain the condensate accumulating during the cooling of gases.

The condensate float traps type ADS have a modified upper section with an additional separator function to separate the condensate from saturated gas flows and simultaneously discharge it.

The traps can only be used in case of overpressure.

Description

The condensate float trap versions AD and ADS operate according to the buoyancy principle.

In the detachable lower section, the buoyancy body closes the drain hole with its valve tip until its own weight is offset by the buoyancy of the rising condensate. The buoyancy body lifts off and the condensate can flow off until its downforce prevails and the valve is closed again.

The respective 3 versions listed differ in terms of materials. AD-P, AD-T, ADS-P and ADS-T have a buoyancy body made of glass, whereas in the case of AD-So and ADS-So, it is made of stainless steel.

Cleaning can be carried out quickly and easily due to the fact that all parts can be dismantled. The functioning of the traps AD-P, AD-T, ADS-P and ADS-T can be visually checked through the glass cylinder.

**Automatic Condensate Float Trap
AD-P/T/So**

**Separator with Automatic Condensate
Float Trap ADS-P/T/So**

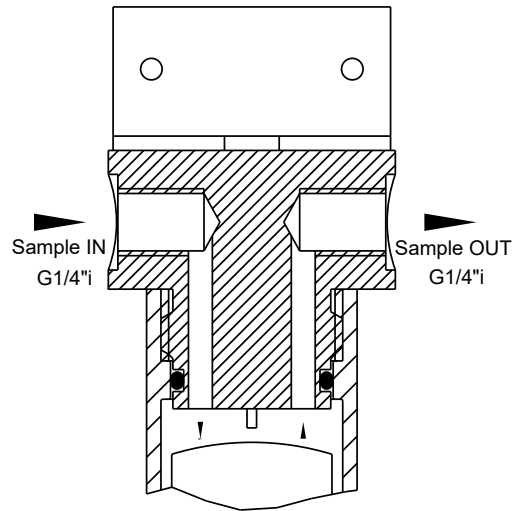
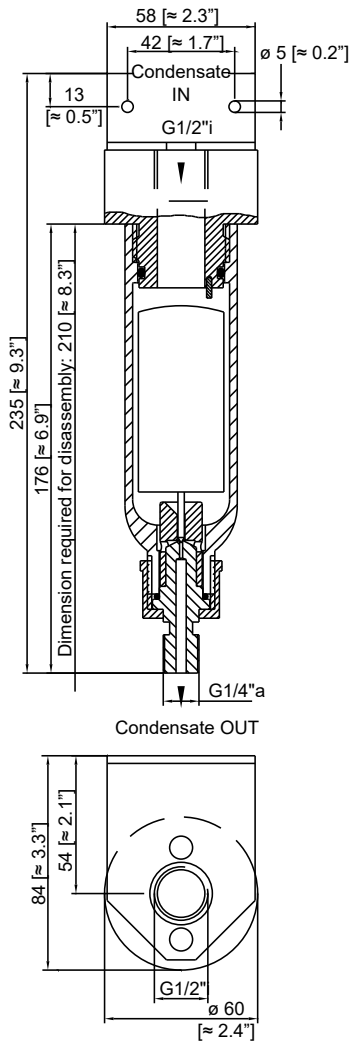

Dimensions in mm [Inches]

Technical Data

	Automatic Condensate Float Trap			Separator with Automatic Condensate Float Trap		
	AD-P	AD-T	AD-So	ADS-P	ADS-T	ADS-So
Part No.	09K1000	09K2000	09K2500	09K6000	09K7000	09K7500
Material						
Housing	PP, glass	PTFE, glass	SS 316Ti	PP, glass	PTFE, glass	SS 316Ti
Float	PP	PVDF	PVDF	PP	PVDF	PVDF
Valve seat, O-rings	PTFE, FKM	PTFE, FEP	PTFE, FKM	PTFE, FKM	PTFE, FEP	PTFE, FKM
Operating temperature	60 °C [140 °F]	90 °C [194 °F]		60 °C [140 °F]	90 °C [194 °F]	
Operating pressure	1 to 2 bar abs.					
Function	Down to min. density 0.7 kg/dm ³ , at 1 bar					
Drain capacity	Max. 2 l/h H ₂ O, at 1 bar and 20 °C [68 °F]					
Mounting position	Vertical					
Connections	Condensate IN: G 1/2" female DIN ISO 228/1* Condensate OUT: G 1/4" male DIN ISO 228/1*			Sample IN/OUT: G 1/4" female DIN ISO 228/1* Condensate OUT: G 1/4" male DIN ISO 228/1*		
Weight	0.35 kg [≈ 0.8 lb]		1.5 kg [≈ 3.3 lbs]	0.35 kg [≈ 0.8 lb]		1.5 kg [≈ 3.3 lbs]

* The dimensions and designation of the screw-in threads correspond to the respective applicable standard. The tolerances of the thread standards are matched to metal threads and cannot be applied to plastic threads.



AD-SS

Automatic Condensate Float Trap

Version AD-SS

Separator with Automatic Condensate Float Trap

Version ADS-SS

Special Features

- **Safe condensate draining and separation**
- **Completely made of stainless steel**
- **For high pressure and temperature applications**
- **High draining capacity**

Application

The M&C condensate float traps AD-SS are used in gas conditioning systems to automatically drain the condensate accumulating during the cooling of gases.

For condensate pre-separation of saturated gas with simultaneous draining, the ADS-SS condensate float traps are provided with a lateral gas connection for additional separator functions.

The traps can only be used with overpressure.

Note for operation !

The M&C condensate float trap AD-SS and the separator ADS-SS have to be filled with water before operation, because otherwise the draining valve will remain open due to its design!

Description

The AD-SS and ADS-SS condensate float traps operate according to the buoyancy principle. Housing, float, valve and valve seat are made of stainless steel. The outlet valve is controlled by a free-floating lever mechanism. The buoyancy body closes the drain hole with the valve tip via the lever mechanism until its own weight is offset by the buoyancy of the rising condensate. The buoyancy body lifts off and the condensate can flow off until its down-force prevails and the valve is closed again.

The ADS-SS separator with an automatic condensate trap is a modified version of AD-SS with an additional lateral gas connection.

Automatic Condensate Float Trap AD-SS, Separator with Automatic Condensate Float Trap ADS-SS

Mounting Clip AD-SS for Wall-Mounting

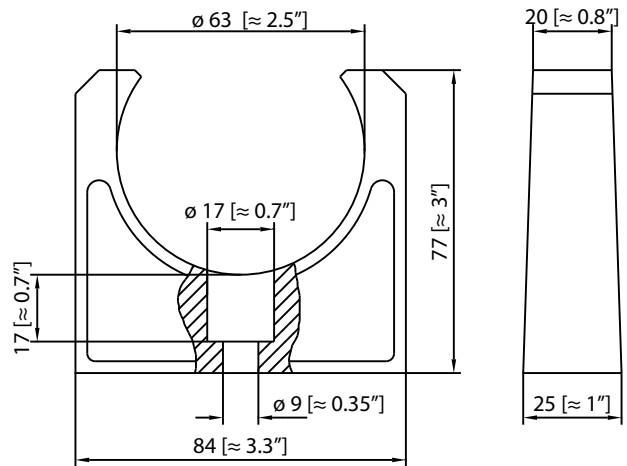
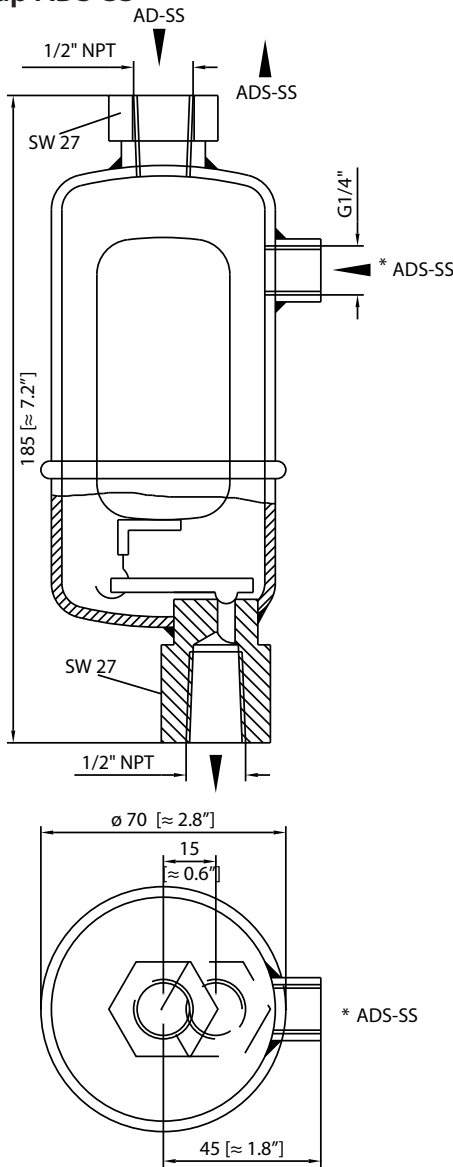

Drain capacity depending on working pressure

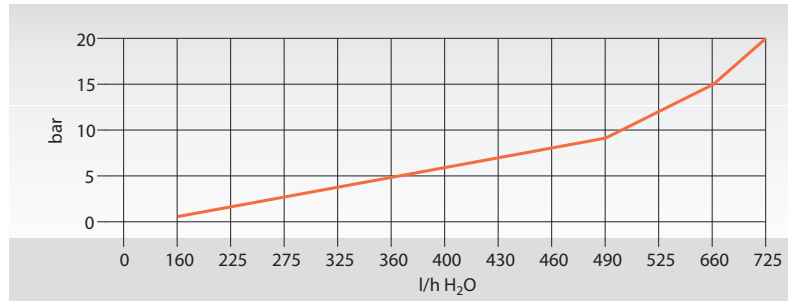

Max. working pressure depending on specific gravity

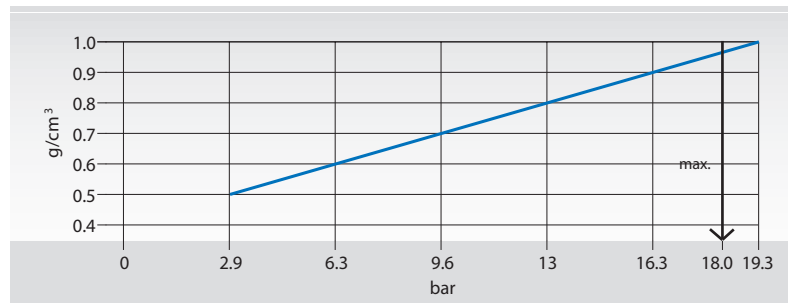

Dimensions in mm *Only for version ADS-SS, this connection is not available for AD-SS.

Technical Data

	Automatic Condensate Float Trap	Separator with Automatic Condensate Float Trap	Mounting Clip AD-SS for Wall-Mounting
	AD-SS	ADS-SS	Mounting clip
Part No.	09K3000	09K8000	90K3010
Material	Stainless steel 304, 316Ti, 304L		PE
Operating temperature	0 to +200 °C [32 to 392 °F]		-20 to +90 °C [-4 to 194 °F]
Storage temperature	-50 to +200 °C [-58 to 392 °F]		-30 to +110 °C [-22 to 230 °F]
Operating pressure	1 to 19 bar abs.		
Function	Volumetric mass density min. 0.5 kg/dm ³ , at 1 bar abs.		
Draining capacity	160 l/h H ₂ O, at 1 bar abs. and 20 °C [68 °F]		
Mounting position		Vertical	
Condensate IN	1/2" NPT female		
Condensate OUT	1/2" NPT female		
Sample gas IN		G 1/4" female	
Sample gas OUT		1/2" NPT female	
Weight	0.8 kg [≈ 1.8 lbs]		0.05 kg [≈ 0.1lb]



FP-D

Series FP[®], FT[®]

Universal Condensate Separators

Versions FP-D, FT-D, FT-H-D, FS-D, FSS-D
for the separation of gas and liquid

Special Features

- **Reliable separation of gas and condensate**
- **Modular design**
- **Various materials available**
- **Second inlet connection possible**
- **Functioning visible in versions with glass body**
- **Wall-mounting**

Application

The M&C universal condensate separators F...-D are used in analytical technology in saturated gas flow for the separation of gas and liquid.

Description

The M&C condensate separators F...-D for gas-/liquid separation consist of standard parts of the modular designed universal filter series F.

The separator heads FT-D, FT-H-D, FS-D and FSS-D are equipped with a second G 1/4" inlet which is closed by a blind plug. In the case of version FP-D, this connection is closed with an impermeable PVDF membrane.

Version FT-H-D that can be heated up to 180 °C [356 °F] is equipped with an aluminium support ring to stabilize the PTFE head.

The sample gas passes inside the vertical drilling of the element holder into the lower section of the separator body and exits there. The diversion of the flow direction, supported by gravity and the reduction of the flow rate, ensures phase separation.

Using the separator versions with glass body, enables the user to control the function from outside. The optimum position of the O-ring guarantees a sure sealing between the separator body and the separator head.

The separator inlet and outlet can be rotated 180° on the wall-mounting bracket thus enabling an easy adaptation to local circumstances during installation.

Depending on the requirements, the separated liquid can be discharged by means of an externally installed M&C condensate vessel TG/TK, submersion, float trap AD or a peristaltic pump SR25.2.

Universal Condensate Separators FP-D, FT-D, FT-H-D, FS-D, FSS-D

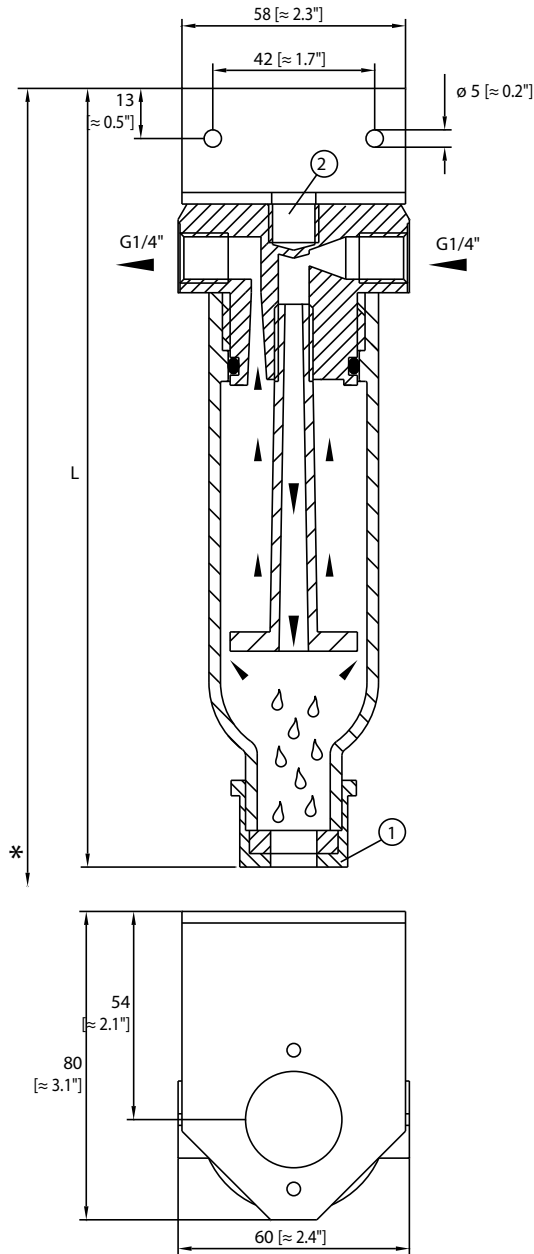

Dimensions in mm [Inches]

Drawing FP/T/S-D with GL 25 drain connection

Version	FP/T/S-D	FSS-D
Constructional size*	310	310
Measure L	210	200
Drain**	GL 25-12	G 1/4" female
Connection**	G 1/4" female	G 1/4" female

* See drawing for assembly/disassembly dimensions, marked with "**"

** Only for version FP-D: If required, open the third G 1/4" female thread connection, which is closed by the impermeable PVDF membrane, with a 5-mm drilling and connect it with the inlet. Versions FT/S/SS-D have a blind plug to close this connection.

Technical Data

	FP-D	FT-D	FT-H-D	FS-D	FSS-D
Part No.	50F1000	50F2000	50F3500	50F2500	50F3000
Material: Separator head, element holder, O-Ring, body	PVDF, FKM, glass	PTFE, FEP, glass	PTFE carbon reinforced, FKM, glass	Stainless steel 316Ti, FKM, glass	Stainless steel 316 Ti, FKM, SS 316 Ti
Operating temperature, max.	+80 °C [176 °F]	+100 °C [212 °F]	+180 °C [356 °F]	+160 °C [320 °F]	+180 °C [356 °F]
Storage temperature	-30 to +120°C [-22 to 248 °F]				
Operation pressure, max.	At 20 °C [68 °F] 2 bar abs., 5 bar abs. when using GL connecting adapters				At 50 °C [122 °F] 250 bar At 180 °C [356 °F] 50 bar
Internal dead volume	80 cm ³				
Type of Mounting	Wall-mounting with fixing bracket, installation position vertical				
Gas connections	G 1/4" female DIN ISO 228/1 ¹⁾				
Liquid drain connection	GL 25-12 mm standard				G 1/4" female
Weight, approx.	0.3 kg [≈ 0.7 lbs]	0.4 kg [≈ 0.9 lbs]	0.5 kg [≈ 1.1 lbs]	1.0 kg [≈ 2.2 lbs]	1.5 kg [≈ 3.3 lbs]

¹⁾ The dimensions and designation of the screw-in threads correspond to the respective applicable standard. The tolerances of the thread standards are matched to metal threads and cannot be applied to plastic threads.



SR25.1/Ex inside SS enclosure

Peristaltic Pump Series SR25®



Version SR25.1, SR25.1/Ex

Special Features

- Safe condensate removal
- With return stop
- Self-priming
- Slow rotational speed
- Hose with long service life
- Explosion-proof version according to ATEX for zone 1

Application

The peristaltic pump SR25.1 has been specially developed for the condensate removal in analysis applications. It ensures a continuous condensate discharge in gas coolers, condensate collecting vessels, etc. A synchronous motor and the gearing unit with return stop make a condensate backflow impossible.

The flow rate of 0.3 NI/h guarantees a safe condensate removal, for example when cooling 850 NI/h sample gas with an initial dew point of +70 °C [158 °F].

The peristaltic pump SR25.1 is used as a spare part for older electric gas coolers of type EC30, EC, ECS, EC-FD, and ECC. For these electro gas coolers the peristaltic pump is mounted in the front plate or housing wall.

For new designs and for use as a surface mounted unit, the successor model SR25.2.W should be used instead of SR25.1 (see data sheet "Peristaltic Pump Series SR25®, SR25.2, SR25.2-G, SR25.2-W").

- Electrical mains connection for 230 V/50 Hz or 115 V/60 Hz is standard.
- The peristaltic pump SR25.1 is designed as a built-in device.
- Up to 4 peristaltic pumps SR25.1 can be installed in the electric gas cooler type EC (see data sheet "Gas Cooler Series EC®, Version ECS and EC-EX for 4 x 250 NI/h").
- The peristaltic pump SR25.1/Ex is a surface-mounted device and can also be mounted into a front panel. SR25.1/Ex is suitable for use in zone 1 hazardous areas.

Description

The peristaltic pump SR25.1 is self-priming and designed for continuous operation. It consists of 3 compact components:

- synchronous motor
- gearing unit with return stop
- pump.

The slow rotational speed (5 rpm), the two PVDF hose contact pulleys and the Novoprene hose guarantee a good mechanical and chemical resistance with a long service life. A possible hose change can be carried out very easily by using ready-made hose sets. The clamping hose connectors DN 4/6 also allow the connection of Teflon® hoses.

Peristaltic pump SR25.1

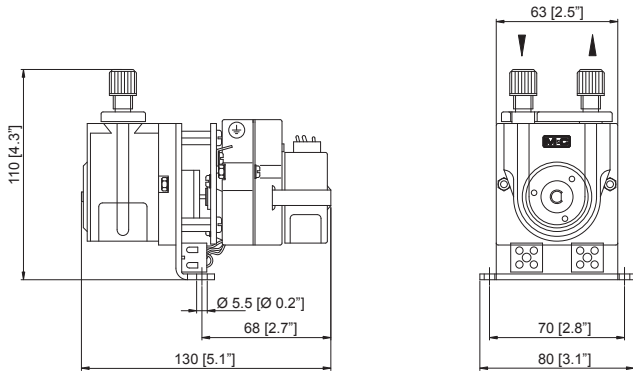

Peristaltic pump SR25.1/Ex

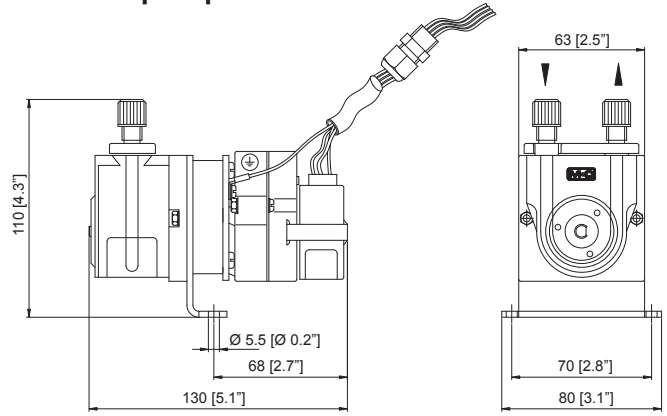

Dimensions in mm [Inch]
Metric dimensions are rounded. Inch dimensions are for reference only. In case of doubt or conflict, metric units take priority.

Technical Data

Peristaltic pump Series SR25®	Version SR25.1	Version SR25.1/Ex
Part number	01P1000	01P1201
Housing	No	No
Method of mounting	Surface-mounted or built-in	Surface-mounted or built-in
Protection/Electrical standard	IP10 EN 60529	IP40, II 2 G Ex m II T5 Certificate No. KEMA 03ATEX2218 X
Electrical connection	Terminal 1.5 mm ²	600 mm [≈ 23.6"] cable 4 x 0.5 mm ² with cable gland M20 x 1.5
Dimensions (W x H x D)	80 x 110 x 130 mm [≈ 5.12" x 4.33" x 3.15"]	
Weight	0.6 kg [≈ 1.32 lb]	0.7 kg [≈ 1.54 lb]
Rotational speed	5 rpm standard	
Flow rate	0.3 NI/h standard	
Suction max.	200 mbar abs.	
Pressure max.	2200 mbar abs.	
Sample temperature	0 to +60 °C [32 to 140 °F]	
Ambient temperature	0 to +50 °C [32 to 122 °F]	+5 to +50 °C [41 to 122 °F]
Storage temperature	-10 to +60 °C [14 to 140 °F]	
Tube connectors	DN 4/6 mm	
Material of sample contacting parts	PVDF, Novoprene	
Power supply/consumption	115/230 V 50/60 Hz / 3.5 VA	
Duty cycle	100 % duty cycle	

Please note: NI/h and NI/min refer to the German standard DIN 1343 and are based on these standard conditions: 0 °C [32 °F], 1013 mbar.

SR25.1/Ex Options

Part No.	SR25.1/Ex with Ex connection box and enclosure
01P1250	1 x SR25.1/Ex peristaltic pump with Ex connection box and SS enclosure for one peristaltic pump, dimensions (W x H x D): 205 x 220 with cable gland x 175 mm [≈ 8.1" x 8.7" with cable gland x 6.9"]
01P1260	2 x SR25.1/Ex peristaltic pumps with Ex connection box and SS enclosure for up to 4 peristaltic pumps, dimensions (W x H x D): 400 x 235 x 175 mm [≈ 15.7" x 9.3" x 6.9"]
01P1270	3 x SR25.1/Ex peristaltic pumps with Ex connection box and SS enclosure for up to 4 peristaltic pumps, dimensions (W x H x D): 400 x 235 x 175 mm [≈ 15.7" x 9.3" x 6.9"]
01P1280	4 x SR25.1/Ex peristaltic pumps with Ex connection box and SS enclosure for up to 4 peristaltic pumps, dimensions (W x H x D): 400 x 235 x 175 mm [≈ 15.7" x 9.3" x 6.9"]

Part No.	Ex connection box for up to 4 x SR25.1/Ex peristaltic pump(s) (without peristaltic pump(s) and enclosure)
01P9400	Ex connection box for 1 x SR25.1/Ex: terminals max. 4 x 2.5 mm ² , cable glands 2 x M20 x 1.5, protection IP65, electrical standard II 2 G Ex e II T5, dimensions (W x H x D): 75 x 80 x 55 mm [≈ 2.95" x 3.15" x 2.17"], weight: 0.35 kg [≈ 0.77 lb]
01P9405	Ex connection box for max. 4 x SR25.1/Ex: terminals max. 16 x 2.5 mm ² , cable glands 5 x M20 x 1.5, protection IP65, electrical standard II 2 G Ex e II T5, dimensions (W x H x D): 160 x 75 x 55 mm [≈ 6.3" x 2.95" x 2.17"], weight: 0.6 kg [≈ 1.32 lb]

Part No.	Enclosure and Ex connection box for 1 x SR25.1/Ex peristaltic pump (without peristaltic pump)
01P9401	SS enclosure: dimensions (W x H x D): 205 x 220 with cable gland x 175 mm [≈ 8.1" x 8.7" with cable gland x 6.9"]; Ex connection box for 1 x SR25.1/Ex: terminals max. 4 x 2.5 mm ² , cable glands 2 x M20 x 1.5, protection IP65, electrical standard II 2 G Ex e II T5, dimensions (W x H x D): 75 x 80 x 55 mm [≈ 2.95" x 3.15" x 2.17"], weight: 0.35 kg [≈ 0.77 lb]



SR25.2

Peristaltic Pump Series SR25®

SR25.2, SR25.2-G, SR25.2-W

SR25.3, SR25.3-G, SR25.3-W

SR25.6, SR25.6-G, SR25.6-W

Special Features

- **Reliable condensate removal**
- **With return stop**
- **Self-priming**
- **Slow speed**
- **Tubing with long service life**

Application

The peristaltic pump series SR25 has been specially developed for condensate removal in analysis applications. It ensures a continuous condensate discharge in gas coolers, condensate collecting vessels, etc. A synchronous motor and the gearing unit with return stop prevent the condensate from flowing back.

The capacity of 0.3 l/h guarantees a safe condensate removal, for example when cooling 850 l/h sample gas with an initial dew point of +70 °C [158 °F].

- The peristaltic pump SR25.2/3/6-W can be used as a panel mounting and built-in unit.
- Different models can be used depending on the required pumping capacity of the peristaltic pump. The SR25.3 can be used for up to 1 rpm, the SR25.2 for 5 rpm, and the SR25.6 for 10 rpm.

Description

The peristaltic pump series SR25 is self-priming and designed for continuous operation. It consists of 3 compact parts:

- synchronous motor
- gearing unit with return stop and
- pump head.

The slow speed, the two PVDF contact pulleys and the different tubing materials guarantee a good mechanical and chemical resistance with a long service life. Pre-assembled flexible tubing sets make it easy to replace tubes, even without using any tools. The tube connector DN 4/6 also allows connecting a PTFE tube.

- The peristaltic pump SR25 is equipped with 230 V/50 Hz or 115 V/60 Hz power supply.
- The peristaltic pump SR25.2/3/6 is designed as a built-in unit for coolers. Up to four peristaltic pumps SR25.2/3/6 can be installed e.g. in the EC electric gas cooler (see data sheet "Gas Cooler Series EC®, Version ECS and EC-EX for 4 x 250 NI/h").
- The peristaltic pump SR25.2/3/6-G is supplied in a wall-mounted housing.

Dimensions

Peristaltic pump SR25.2

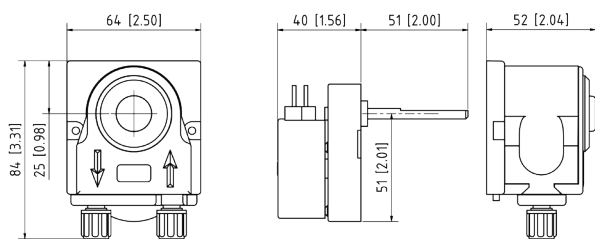

Peristaltic pump SR25.2-W

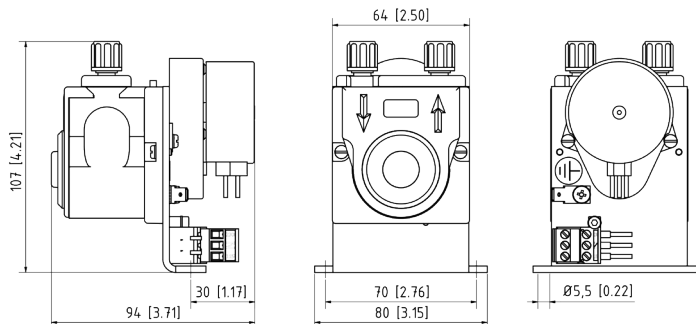

Peristaltic pump SR25.2-G in wall-mounting housing

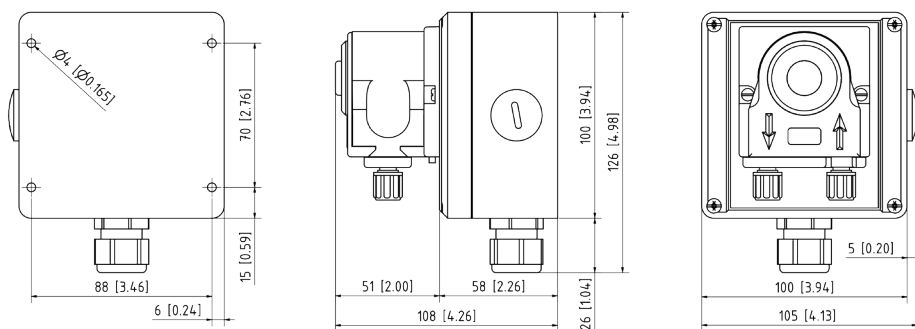

Dimensions in mm [Inches]

Metric dimensions are rounded. Inch dimensions are for reference only. In case of doubt or conflict, metric units take priority.

Technical Data

Peristaltic pump Series SR25*	Version SR25.2/3/6	Version SR25.2/3/6-G	Version SR25.2/3/6-W
Part No.	SR25.2 01P1300 SR25.3 01P1310 SR25.6 01P1350	SR25.2-G 01P1120 SR25.3-G 01P1110 SR25.6-G 01P1400	SR25.2-W 01P1307 SR25.3-W 01P1320 SR25.6-W 01P1360
Housing	No	Yes; material: polycarbonate (PC)	No
Method of mounting	Attached to a front plate	Wall-mounting	Inside or attached to an enclosure
Protection/electrical standard	IP10 EN 60529	IP52 EN 60529	IP10 EN 60529
Electrical connection	Terminal 1.5 mm ²	Terminal 1.5 mm ² , 1 x M20 x 1.5	Terminal 1.5 mm ²
Dimensions in mm [Inches] [H x W x D]	64 x 84 x 52 plus 40 for the motor [≈ 2.50" x 3.31" x 2.04" plus 1.56"]	126 x 105 x 108 [≈ 4.98" x 4.13" x 4.26"]	80 x 107 x 94 [≈ 3.2" x 4.2" x 3.7"]
Weight in kg [lbs]	0.4 [≈ 0.88 lbs]	0.6 [≈ 1.3 lbs]	0.5 [≈ 1.10 lbs]
Suction max.	200 mbar abs.		
Pressure max.	2200 mbar abs.		
Sample temperature	0 to +60 °C [32 to 140 °F]		
Ambient temperature	0 to +50 °C [32 to 122 °F]		
Storage temperature	-10 to +60 °C [14 to 140 °F]		
Material of sample-contacting parts	PVDF, Novoprene		
Power supply/consumption	115/230 V, 50/60 Hz/5 VA		
Continuous duty	100 % ED		
Medium connections (gas connections) made of PVDF	Tube connections DN 4/6 (standard) Tube support 4 Tube connection 6/8 Tube connection 1/4"		

Material of sample-contacting parts (tubing)

Novoprene® (standard) used for water, weak acids or bases

Masterflex® (reinforced contact springs necessary!) used for strong acids or bases, carbon disulfide, toluene, gasoline; alcohols

Chemzure® used for methylethyl ketone, acetone, tetrahydrofuran

Selection for Novoprene tubing (standard)

Peristaltic pump version	SR25.3-G/W	SR25.2-G/W	SR25.6-G/W
Rotational speed (revolutions per minute)	1 rpm	5 rpm	10 rpm
Pumping capacity	Tubing Ø 1.6 mm ID	0.012 l/h (standard)	0.12 l/h
	Tubing Ø 3.2 mm ID	0.05 l/h	0.3 l/h (standard)
	Tubing Ø 4.8 mm ID	0.08 l/h	0.4 l/h
			0.8 l/h (standard)

Other tubing materials and sizes on request.

Chemraz® is a registered trademark for perfluoroelastomer by Greene Tweed, USA.

Masterflex® is a registered trademark for tubes of Masterflex Group, Germany.



TG10

Condensate Vessel

Versions TG1, TG1/LA1, TG10, TK10, TK11, TK12/LA5, TK13

Special Features

- **Very corrosion-resistant**
- **Liquid level always visible**
- **Different tube connections possible**
- **Liquid level alarm possible**
- **With integrated tap**

Application

The TG/TK collection vessels are specially designed for problems in analytical technology and are used as condensate collecting vessels where automatic condensate disposal, e.g. at gas coolers, is not possible or desired, e.g. when only very small quantities of condensate are accumulated. In applications in which automatic condensate removal with a peristaltic pump is likely to result in increased condensate ingress, the collection vessel is also used as a buffer vessel. For safe operation, the collection vessels can be equipped with a liquid level alarm.

The TK11 and TK12/LA5 collection vessels are equipped with an M28 connection thread for the LA5 float switch for liquid level monitoring. The TK12/LA5 collection vessel is supplied completely with the integrated LA5 float switch with 1-m LIYY 2 x 0.14 mm² connection cable.

The manual drain valve of the TK10-TK12/LA5 collection vessels is equipped with a PVC O-ring sealed valve, which guarantees smooth operation and tightness. Three G 1/4" thread connections allow easy horizontal or vertical installation.

The horizontal connections are factory-sealed with blind plugs.

Wall-mounting profiles are an integral part of the collection vessels.

The 10 liter M&C collection vessel TK13 and TK13/LA5 with carrying handle and manual tap are made of PE. The TK13 and TK13/LA5 have three tube connections DN 4/6 for condensate inlet and ventilation.

The TK13/LA5 collection vessel is supplied with the integrated float switch LA5 with 1-m connection cable LIYY 2 x 0.14 mm² for liquid level monitoring.

The LA5 float switch is supplied as a make contact by the manufacturer. If you need a normal close contact, turn the float 180°.

Description

The M&C TG1 and TG10 collection vessels are made of industrial quality glass. This ensures high corrosion resistance and a good visibility into the vessel. A GL 25-12 clamping ring connection is available for the condensate inlet and for TG1 additionally for an optional liquid alarm sensor (not for TG10), which is supplied sealed with a blind cap.

The manual tap is equipped with a PTFE plug valve, which guarantees smooth operation and tightness. All parts in contact with the medium are made of Duran® glass and PTFE. A wall bracket is supplied as standard. The version TG1/LA 1 is supplied completely with a liquid sensor LA1S for conductive media incl. evaluation electronics LA1.1 in wall-mounted version. Special connection adapters for connecting tubes to GL connections are optionally available.

The M&C collection vessels TK10-TK12/LA5 are made of transparent PVC. High corrosion resistance and insight into the vessel are ensured. The TK10-TK12/LA5 has a G 3/8" connection for the condensate inlet. For possible special functions, the TK10 collecting vessel also has two G 1/4" connections which are closed with blind plugs. The TK12 collecting vessel has one G 1/4" connection for ventilation purposes.

Condensate vessel TG1

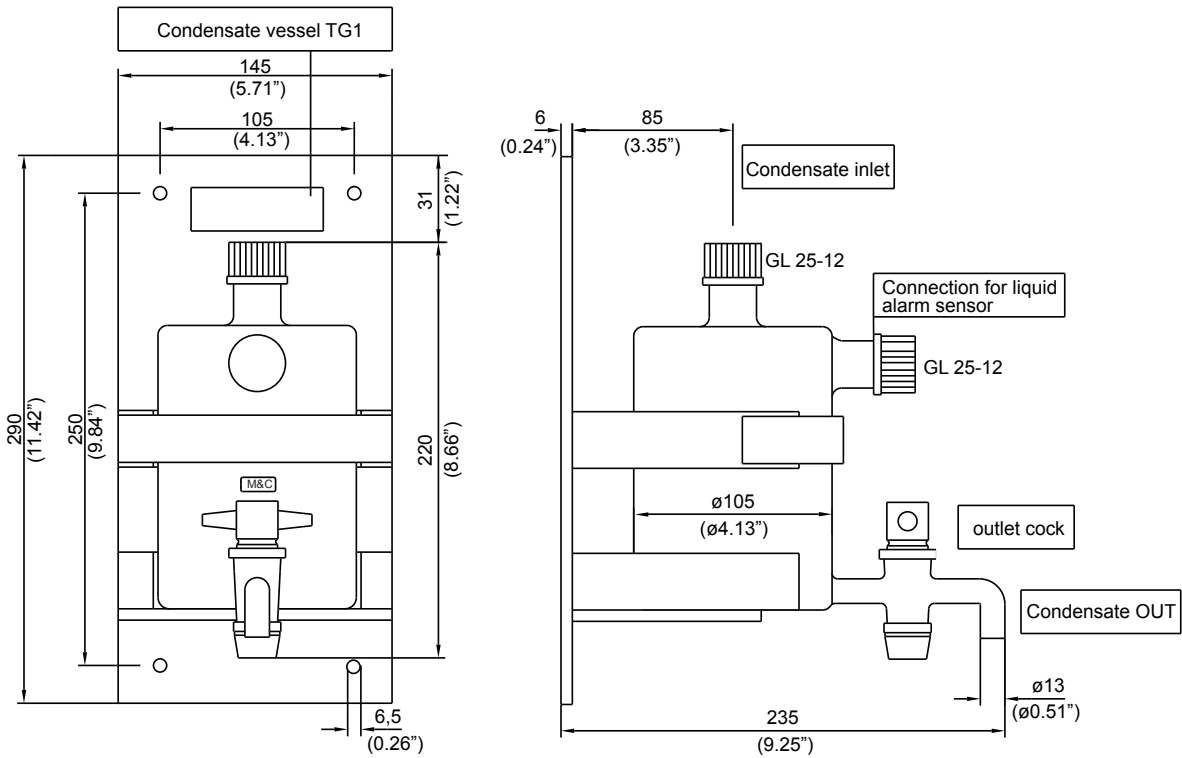

Condensate vessel TK10

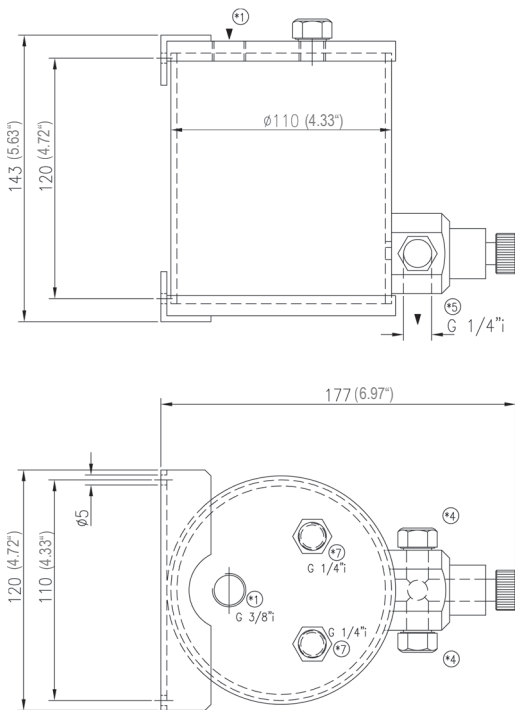

Condensate vessel TK11, TK12/LA5

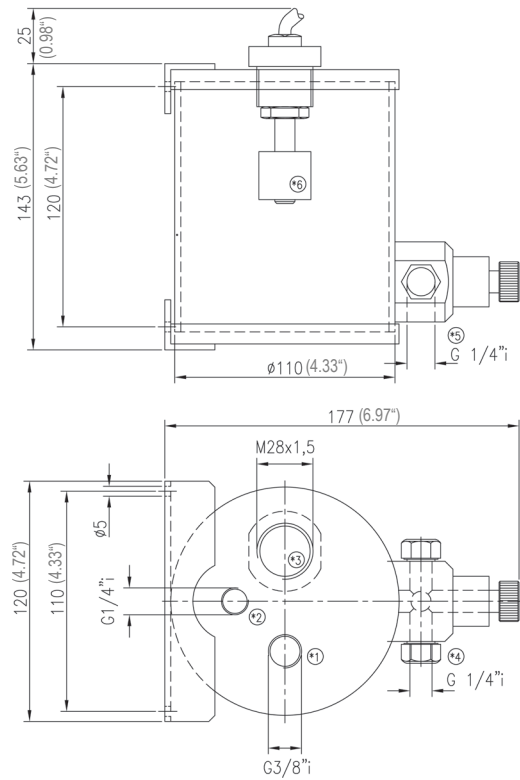

Dimensions in mm

- *1: Condensate IN
- *2: Ventilation
- *3: Connection thread for liquid level alarm LA5
- *4: Condensate OUT (lateral)
- *5: Condensate OUT (downwards)
- *6: Liquid level alarm LA5
- *7: Two additional connections, which are sealed with blind plugs

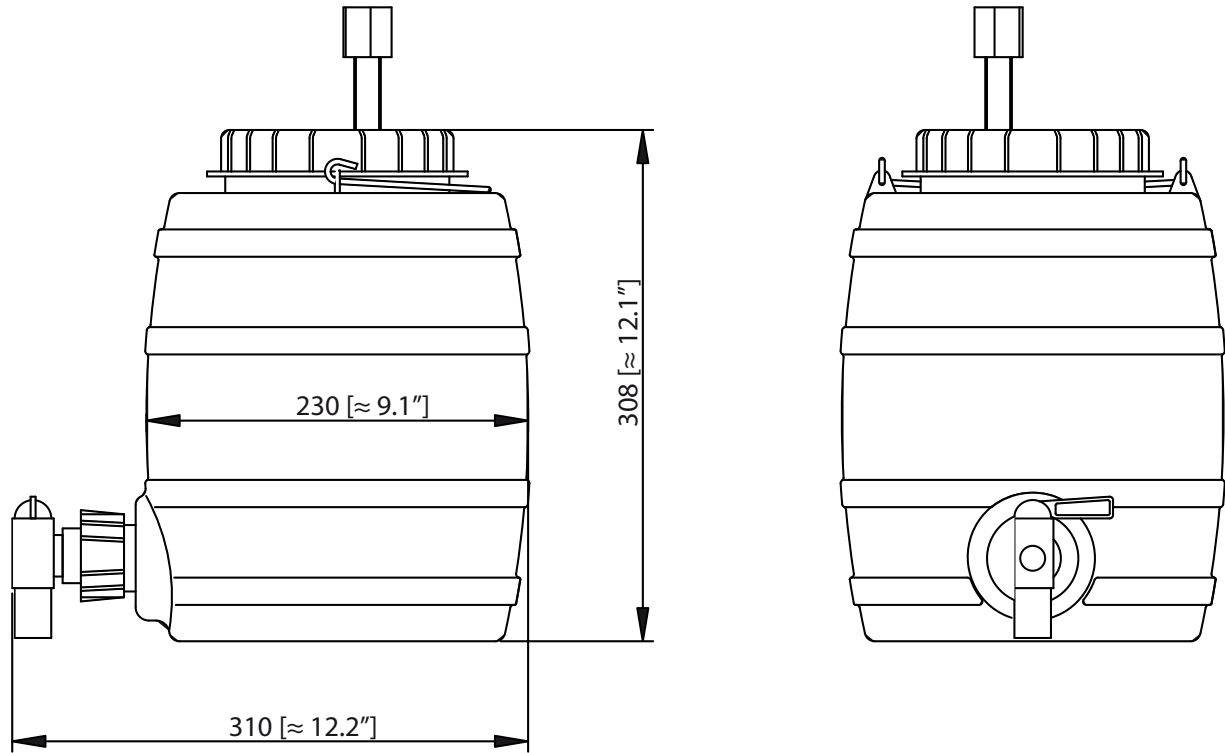

Technical Data

Condensate vessel	TG1	TG1/LA1	TG10
Part No.	09K4000	09K4100	09K4050
Contents	Approx. 1 liter [≈ 0.3 gal]		
Operating pressure at 20 °C [68 °F]	0.2 to 2 bar abs.		
Sample temperature	0 to +80 °C [32 to 176 °F]		
Ambient temperature	0 to +55 °C [32 to 131 °F]		
Storage temperature	-15 to +65 °C [5 to 149 °F]		
Material of sample-contacting parts	Duran® glass, PTFE		
Dimensions (W x H x D)	145 x 290 x 235 mm [≈ 5.7" x 11.4" x 9.3"]		
Connections	1 x GL 25-12, 1 x GL 25, 1 x 13 mm nipple	2 x GL 25-12, 1 x 13 mm nipple	1 x GL 25-12, 1 x 13 mm nipple
Weight	1 kg [≈ 2.2 lbs]	1.2 kg [≈ 2.7 lbs]	1 kg [≈ 2.2 lbs]
With liquid level alarm unit	NO (option)	YES	NO
Power supply		115/230 V 50/60 Hz 2 VA	

Condensate vessel	TK10	TK11	TK12/LA5	TK13	TK13/LA5
Part No.	09K4250	09K4200	09K4300	09K4310	09K4320
Contents approx.	1 liter [≈ 0.3 gal]			10 liters [≈ 2.6 gal]	
Operating pressure at 20 °C [68 °F]	0.2 to 2 bar abs.			Atmospheric	
Sample temperature	0 to +50 °C [32 to 122 °F]				
Ambient temperature	0 to +55 °C [32 to 131 °F]				
Storage temperature	-15 to +65 °C [5 to 149 °F]				
Connection condensate IN	1 x G 3/8" i, 2 x G 1/4" i	1 x G 3/8" i, 1 x M 28 x 1.5 i	1 x G 3/8" i, 1 x M 28 x 1.5 i, 1 x G1/4" i (ventilation)	3 x DN 4/6	2 x DN 4/6
Connection condensate OUT	3 x G 1/4" i			Plug valve opening ø 11.5	
Dimensions	See drawing			ø 235 mm [ø ≈ 9.3"], height 310 mm [≈ 12.2"]	
Weight	0.5 kg [≈ 1.1 lbs]		0.6 kg [≈ 1.3 lbs]	1 kg [≈ 2.2 lbs]	
Sample-contacting parts	PVC, FKM	PVC, FKM	PVC, FKM	PE, rubber, PVDF	
With liquid level alarm	NO	NO (option)	YES	NO	YES
Contact rating			48 V 0.5 A 10 W		48 V 0.5 A 10 W

Duran® is a registered trademark for borosilicate glass by DWK Life Sciences GmbH, Germany.