

# Product Category Gas Conditioning.

Gas Coolers | Condensate Removal | Filters | Gas Conditioning Systems |  
Gas Converters | Gas Dilution | Wash Bottles & Humidifiers | Liquid Stops





CSS

# 19" Gas Conditioning Unit Series CSS®

Version CSS for max. 150 NI/h  
Version CSS-3 for max. 350 NI/h

## Special Features

- **Completely pre-installed and ready for operation within 10 minutes**
- **Individually configurable**
- **Self-monitoring and minimum maintenance**
- **Up to 5 calibration gases manually or externally switchable**
- **One or two gas path(s)**
- **Water vapor dew point input up to +80 °C [176 °F]**
- **Outlet dew point adjustable from +2 to +15 °C [35.6 to 59 °F]**
- **Dew point stability ± 0.1 °C [± 0.18 °F]**

## Application

With these units, completely pre-installed gas conditioning systems for continuous operation have been created, which can be integrated excellently into analyzer systems. The compact design requires only little space. The conditioning units are ready for operation within a few minutes.

The usual time-consuming procurement of individual components and small parts as well as their assembly have finally become superfluous. Application examples of the CSS and CSS-3 sample gas conditioning systems are flue gas and process gas conditioning. In the event of special problems, such as aerosols, various solvents, explosive gases or installation areas in Ex zones, we can propose further solutions.

In the event of failure, the liquid alarm automatically switches off the gas pump and the inlet solenoid valve.

Great importance was attached to the maintenance-friendly design of the unit. The parts to be maintained are easily accessible via a removable front sub-panel without having to disassemble the entire system.

The CSS or CSS-3 sample gas conditioning units in a 19" rack are available for 230 V or 115 V AC mains voltage.

The CSS-3/C sample gas conditioning unit provides the possibility of directly injecting calibration gas to the sample gas probe, e.g. SP2000-H/R, for the calibration of the complete system.

## Description

The M&C gas conditioning units CSS and CSS-3 are compact, low-maintenance, self-monitoring and completely equipped units (see table page 3) suitable for standard applications.

Toggle switches for the different functions are located on the front panel:

EXTERNAL-INTERNAL	→	ON
PUMP OFF	↔	PUMP ON
MEASURE	↔	CHECK
SAMPLE GAS	↔	TEST GAS
ZERO GAS	↔	SPAN GAS

With an optional 4-position rotary switch, it is possible to select more than one calibration gas. Active functions are indicated by LEDs.

All functions of the CSS or CSS-3 can be controlled externally via potential-free contacts, e.g. an automatic calibration device of an analyzer.

The sample gas pump is integrated in an automatic interlock circuit and is only switched on when the electric gas cooler reaches an operating temperature of < +8 °C [45 °F].

# Functional Diagramm

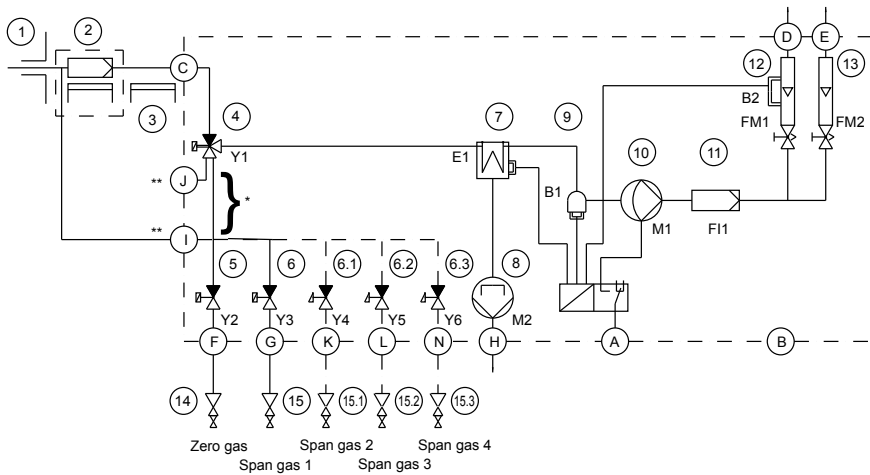

- 1 Gas sample probe SP2000-H
- 2 Heated filter
- 3 Heated sample line 4M.
- 4 3-way solenoid valve 124C3
- 5 2-way solenoid valve 2011
- 6 2-way solenoid valve 2011
- 7 Gas cooler ECP1000/3000
- 8 Peristaltic pump SR25.1
- 9 Liquid sensor LA1
- 10 Diaphragm pump N3/9 KPE
- 11 Gas filter PPF0,1
- 12 Flow meter with alarm FM40 / FA1
- 13 Flow meter FM40
- 14 Zero gas
- 15 Span gas, standard 1 x, optional + 3 x
- A Status alarm/remote control of valves
- B Power supply
- C Sample gas INLET
- D Sample gas OUT 1 with flow alarm
- E Sample gas OUT 2
- F Zero gas IN
- G Span gas IN
- H Condensate OUT
- I Test gas to the probe \*\*only in CSS-3/C
- J Vent \*\*only in CSS-3/C
- K Span gas 3 - IN option
- L Span gas 3 - IN option
- N Span gas 4 - IN option

\* No tubing for version CSS-3/C  
 \*\*Only in CSS-3/C

## Dimensions

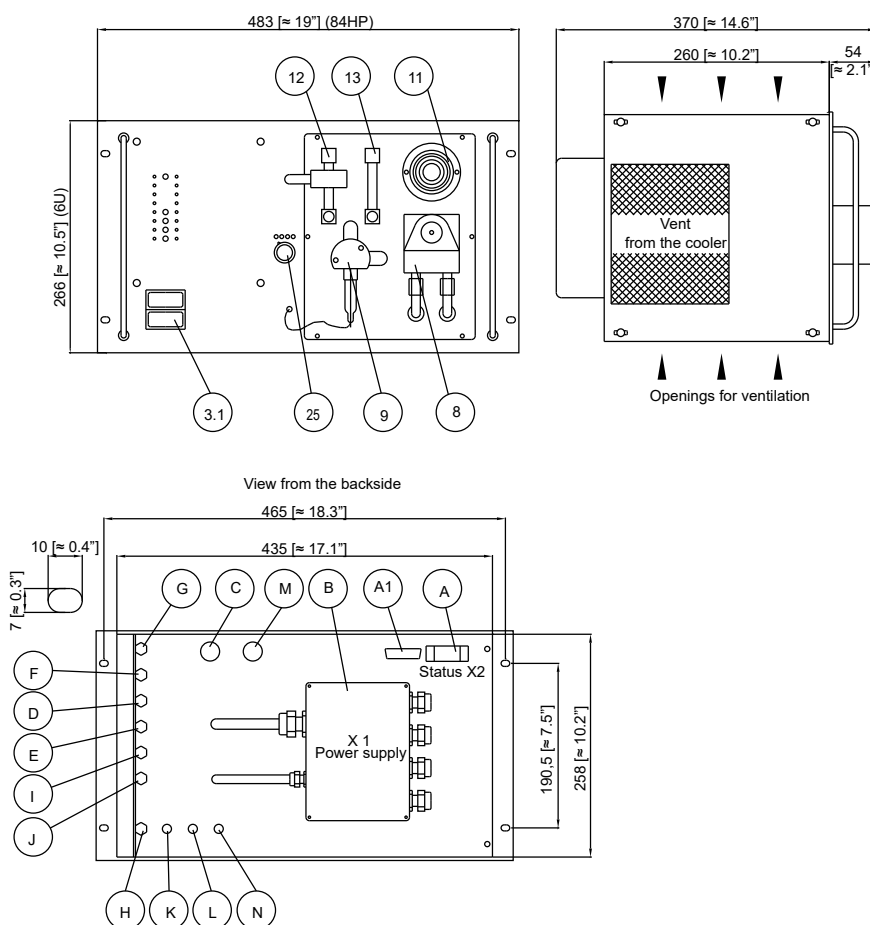

- 3.1 Temperature controller 703 option
- 8 Peristaltic pump SR25.1
- 9 Liquid alarm sensor LA1
- 11 Fine filter PPF 0,1
- 12 Flow meter with alarm FM40/FA1
- 13 Flow meter FM40
- A Status alarm/remote control of valves
- A1 Reserve
- B Power supply
- C Sample gas INLET
- D Sample gas OUT 1 with flow alarm
- E Sample gas OUT 2
- F Zero gas IN
- G Span gas IN
- H Condensate OUT
- I Test gas to the probe \*\*only in CSS-3/C
- J Vent \*\*only in CSS-3/C
- K Span gas 2 - IN option
- L Span gas 3 - IN option
- M Reserve
- N Span gas 4 - IN option

Dimensions in mm [Inches]

19" Gas Conditioning System Series CSS*	Version CSS	Version CSS-3
Inlets and max. gas flow**	1 x 140 NI/h	1 x 350 NI/h
Outlets incl. flow meters	2 x 70 NI/h	2 x 250 NI/h
Gas pressure	0.7 to 1.2 bar abs.	
Sample gas inlet temperature**	Max. 150 °C [302 °F]	
Sample gas inlet dew point**	Max. 80 °C [176 °F]	
Sample gas outlet dew point	Range of adjustment: +2 to +15 °C [36 to 59 °F], factory setting: +5 °C [41 °F]	
Dew point stability	At constant conditions < ±0.1 °C [< ±0.18 °F]	
Ambient temperature**	+5 to +40 °C [41 to 104 °F]	+5 to +45 °C [41 to 113 °F]
Total cooling capacity at +25 °C [77 °F] ambient temperature	Max. 50 kJ/h	Max. 90 kJ/h
Storage temperature	-25 to +65 °C [-13 to 149 °F]	
Relative humidity	< 80 %	
Ready for work	Approx. 10 min	
Gas filter	Glass fiber, porosity 0.1 µm	
Housing	19" rack mounting 6 U, depth 350 mm [≈ 13.8"], color RAL 7032	
Degree of protection	IP20 EN 60529	
Tube connections	G 1/4" female (standard), DIN ISO 228/1*	
Power supply	230 V, 48-62 Hz, 150 VA or 115 V, 48-62 Hz, 150 VA	230 V, 48-62 Hz, 250 VA or 115 V, 48-62 Hz, 250 VA
Electrical equipment standard	EN 61010	
Electrical connections	Power terminals max 4 mm <sup>2</sup> , 4 x PG 13.5 Alarm/control signals 15-pin Sub-D connector	
Status signal	Cooler temperature, liquid alarm, flow alarm	
Status alarm contact, contact rating	Potential-free changeover contact, max. 24 V, 1 A	
Test gas inlets	2 solenoid valves, actuated manually or via external switch (standard, optional +3 pieces)	
Material of sample-contacting parts	PVDF, glass, FKM, Novopren, PTFE	
Weight	Approx. 15 kg [≈ 33.1 lbs]	Approx. 16.5 kg [≈ 36.4 lbs]
<b>Option:</b>		
Electronic PID temperature controller 703 for heated sample lines	Front-panel mounting, range 0 to 200 °C [32 to 392 °F], sensor PT 100 or Fe-CuNi, controlling outlet with a solid state relays 10 A***, alarm output integrated into the CSS status alarm, parameter freely configurable	

\* The dimensions and designation of the screw-in threads correspond to the respective applicable standard. The tolerances of the thread standards are matched to metal threads and cannot be applied to plastic threads.

\*\* Maximum values in technical data must be rated in consideration of the total cooling capacity at 25 °C [77 °F] ambient temperature and 5 °C [41 °F] outlet dew point.

\*\*\* Standard for max. 20 m heated sample line at 110 W/m.

Please note: NI/h and NI/min refer to the German standard DIN 1343 and are based on these standard conditions: 0 °C [32 °F], 1013 mbar.

Equipment	Conditioning Unit CSS	Conditioning Unit CSS-3
Sample gas inlet	1	
Sample gas outlets	2	
Flow meter with needle valve	FM 40 70 NI/h air	FM 40 250 NI/h air
Electric gas cooler	ECP 1000-G90° for 150 NI/h	ECP 3000-G90° for 350 NI/h
Diaphragm pump	N3KPE	N9KPE
Peristaltic pump	SR 25.1	
Ultra-fine filter	FPF 0,1 GF with glass-fiber filter element 0.1 µm	
External or manual switching from measuring to testing with zero or span gas	1 x 3/2-way solenoid valve 124C3 and 2 x 2/2-way solenoid valves 2011, optional +3 pcs.	
Tubing and connectors	PTFE, PVDF	
Status alarm with optical display	For cooler temperature, flow failure and liquid alarm	
Optional	Electronic temperature controller for heated sample line	

Part No.	
03G1000(a)	19" gas conditioning unit CSS for 140 NI/h (230 V: Part No. 03G1000, 115 V: Part No. 03G1000a)
03G3000(a)	19" gas conditioning unit CSS-3 for 350 NI/h (230 V: Part No. 03G3000, 115 V: Part No. 03G3000a)
03G3100(a)	19" gas conditioning unit CSS-3/C for 350 NI/h and test gas to sample probe (230 V: Part No. 03G3100, 115 V: Part No. 03G3100a)
	<b>Option</b>
03G9020(a)	Extra charge for CSS, CSS-3 with 3 calibration valves (230 V: Part No. 03G9020, 115 V: Part No. 03G9020a)
03G9025(a)	Extra charge for CSS, CSS-3 with 4 calibration valves (230 V: Part No. 03G9025, 115 V: Part No. 03G9025a)
03G9030(a)	Extra charge for CSS, CSS-3 with 5 calibration valves (230 V: Part No. 03G9030, 115 V: Part No. 03G9030a)
03G9000	Extra charge for integrated electronic temperature controller 703 for heated sample line

Special versions upon request.



CSS-M

## Portable Gas Conditioning Unit Series CSS®

Portable version CSS-M for 70 NI/h gas flow rate  
Wall-mounting version CSS-M/W for 70 NI/h gas flow rate

### Special Features

- **Portable or for wall-mounting**
- **Gas outlet dew point adjustable from +2 to +15 °C [35.6 to 59 °F]**
- **Water vapor dew point input up to +50 °C [122 °F]**
- **Gas flow rate 1 x 70 NI/h**
- **Dew point stability  $\leq \pm 0.1$  °C [ $\pm 0.18$  °F]**
- **Low weight (11 kg [ $\approx$  24.3 lbs])**

### Application

The M&C portable gas conditioning unit CSS-M is designed to carry out precise gas analyses at different locations. The version CSS-M/W is a completely pre-installed compact continuous gas conditioning system for wall-mounting.

Both gas conditioning units are housed in a compact and robust sheet steel housing, so that you can carry out or install your gas analyses quickly, with low maintenance and with maximum operating reliability.

The CSS-M gas conditioning unit is suitable for variable, discontinuous use as well as for continuous operation.

The components built into the CSS-M and CSS-M/W gas conditioning units can be used for standard applications.

### Description

The CSS-M and CSS-M/W gas conditioning systems are equipped with a Peltier gas cooler of the ECP series with Jet-Stream heat exchanger, which cools the sample gas to constant +5 °C [41 °F] independent of the ambient temperature. As soon as the operating temperature of < +8 °C [46 °F] is reached after commissioning, the sample gas pump N3KPE is automatically switched on with the gas cooler status contact. The peristaltic pump SR 25.2 ensures continuous condensate drainage, making even long-term measurements possible without any problems. The corresponding particle filtration is carried out with the FPF-2-0.3GF ultra-fine filter, which also has an integrated liquid alarm sensor that switches off the sample gas pump in the event of an alarm. An FM40 flow meter is installed in the sample gas outlet. Flow monitoring is optionally available for the CSS-M/W version.

This means that the two gas conditioning units are complete conditioning systems for most gas analysis devices.

## Flow scheme CSS-M/(W)



- 1 Gas cooler series ECP
- 2 Fine filter FPF-2-0,3GF, filter porosity 0.3 µm with liquid alarm
- 3 Sample gas pump N3KPE
- 4 Flow meter FM40 (CSS-M/W optional with flow alarm)
- 5 Peristaltic pump SR25.2

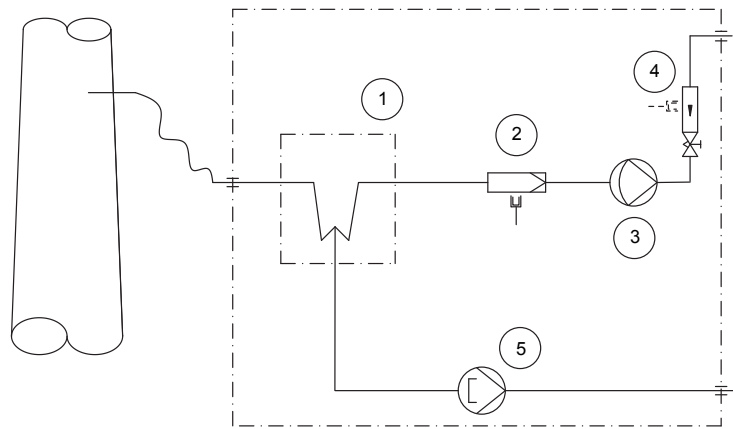

## Dimensions CSS-M

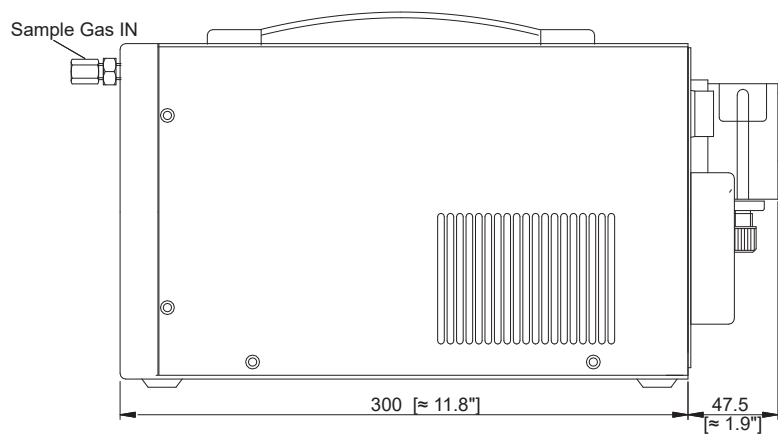
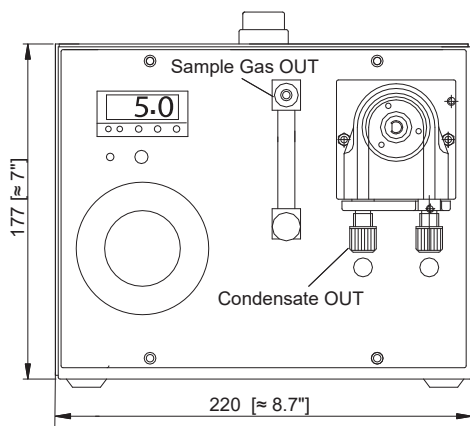

## Dimensions CSS-M/W

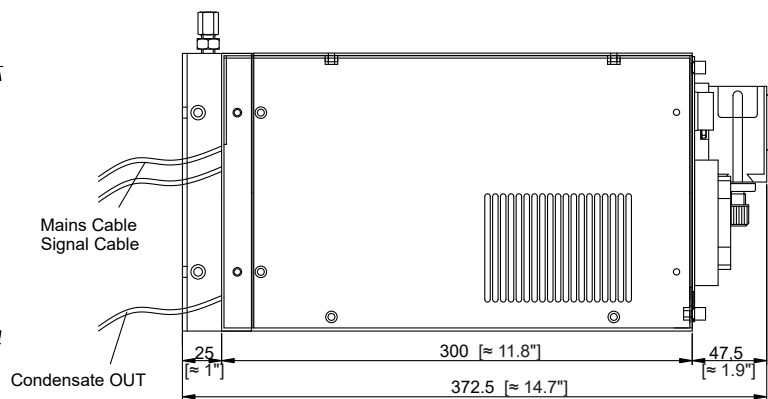
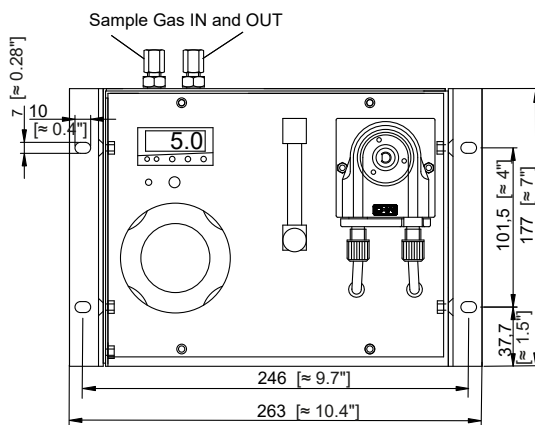

Dimensions in mm [Inches]

Gas Conditioning Unit Series CSS*	Version CSS-M	Version CSS-M/W
Part No. for 230 V/50 Hz version	01G2000	01G2500
Part No. for 115 V/60 Hz version	01G2000a	01G2500a
Sample outlet dew point	Range of adjustment: +2 to +15 °C [36 to 59 °F], factory setting: +5 °C [41 °F]	
Dew point stability	At constant conditions < ±0.1 °C [±0.18 °F]	
Sample inlet temperature*	Max. 80 °C [176 °F]	
Sample inlet dew point*	Max. 50 °C [122 °F]	
Gas flow rate*	Max. 70 NI/h	Max. 70 NI/h
Gas flow alarm	No	Optional Part No. 01G9805
Ambient temperature*	+10 up to +45 °C [50 up to 113 °F]	
Storage temperature	-25 up to +65 °C [-13 to 149 °F]	
Pressure	0.7 bar up to 1.4 bar abs.	
Total cooling capacity*	Max. 40 kJ/h	
Number of gas inlets	1	
Number of gas outlets	1	
Condensate outlet	1	
Medium connections	Tube connection DN 4/6	
Material of sample contacting parts	Glass, PVDF, PVC, Novoprene, Viton®, PPH	
Ready for operation	Approx. 10 min.	
Power supply	230 V/50 Hz or 115 V/60 Hz	
Power consumption	Max. 240 VA	
Fuse protection	4 A t, 5 x 20 mm	
Electrical connection	Cold appliance plug with 2 m cable	Mains cable 3 x 1 mm <sup>2</sup> , signal cable 3 x 0.5 mm <sup>2</sup> , 3 m length
Status alarm, 1 change over contact, potential-free	No	Contact rating 250 V AC, 2 A, collective alarm for gas flow, liquid and cooler temperature
Case protection	IP20 (DIN 40050, IEC 529)	
Sheet steel housing, design	Portable, color grey, RAL 7035	Wall-mounting, color grey RAL 7035
Equipment dimensions (H x W x D)	177 x 220 x 300 mm [≈ 7.0" x 8.7" x 11.8"]	177 x 263 x 372.5 mm [≈ 7.0" x 10.4" x 14.7"]
Electrical equipment standard	EN 61010	
Weight	Approx. 11 kg [≈ 24.3 lbs]	

\* Maximum values in technical data must be rated in consideration of the total cooling capacity at 25 °C [77 °F] ambient temperature and an outlet dew point of 5 °C [41 °F].

Please note: NI/h and NI/min refer to the German standard DIN 1343 and are based on these standard conditions: 0 °C [32 °F], 1013 mbar.

PVDF = Polyvinylidenfluoride

Viton® is a registered trademark used by DuPont Performance Elastomers, USA.



CSS-VC1

## Gas Conditioning Unit Series CSS®

Version CSS-VC1 for max. 1 x 250 NI/h gas flow rate, version CSS-VC2 for max. 2 x 150 NI/h gas flow rate, for 19"-rack or wall-mounting or portable in transport case

### Special Features

- **Compact high-performance design with compressor cooler**
- **Individually configurable**
- **Completely pre-installed**
- **Multifunctional control unit (TCU) with warning and fault indication in plain text**
- **One or two gas paths**
- **19"-rack/wall-mounting/transport case/trolley system**
- **Adjustable dew point outlet: +2 to +7 °C [+ 35.6 to + 44.6 °F]**
- **Water vapor dew point input up to 80 °C [176 °F]**
- **Dew point stability ± 0.1 °C [± 0.18 °F]**
- **Ready for operation in 10 minutes**
- **Operating hours counter**
- **History memory**

### Application

The CSS-VC1 und CSS-VC2 units provide completely pre-installed compact high-performance sample gas conditioning systems for continuous use. Due to the multifunctional expandable control unit TCU and a wide variety of additional options, the sample gas conditioning units can excellently be adapted to the most diverse requirements of gas analysis technology and therefore perform the tasks of complete analyzing systems.

The compact design only requires little space. The CSS-VC1/VC2 units are ready for use in just a few minutes. This makes the time-consuming procurement of individual components and small parts as well as their assembly superfluous. A portable version in a transport case is also possible.

(option): yellow LED, temperature ±3 °C from setpoint and humidity alarm (option): red LED).

The fine filter downstream of the cooler (different filter types possible) ensures the necessary separation of solids. The condition of the filter is visible from the outside. To protect the downstream analyzers against liquid inrush and to increase the operating reliability of the whole system - depending on the selected type of filter - a suitable liquid alarm sensor is possible or already integrated into the filter.

A collective alarm message or, on request, individual alarm messages including mA output for the cooler temperature connected to output terminals are available. Via potential-free contacts for the collective alarm or the individual alarms (cooler temperature, flow rate, liquid in the system), an alarm signal is given and the sample gas pump, if present, is switched off.

### Description

All components of the gas conditioning units are mounted in a robust, compact sheet steel case for wall- or 19"-rack mounting. The ventilation grids in the sidewalls ensure that the equipment is sufficiently ventilated.

Filter, flow meter and peristaltic pumps are located in the front panel and thus ensure easy maintenance. A removable cover and a foldable front plate also allow a quick and easy inspection and maintenance of all other installed components, in particular a simple replacement of heat exchangers.

The compressor gas cooler is equipped with one or two heat exchangers of Duran® glass, stainless steel SS 316Ti or PVDF. Peristaltic pumps type SR25.2 are used for continuous condensate removal or are also used as dosing pumps. The current cooler temperature is displayed on the multifunctional TCU control unit installed at the front. The setpoint temperature of the cooler can be set via keys. In case of warnings or malfunctions, plain text information is shown on the display and additionally indicated by LEDs (cooler within the setpoint range: green LED, flow alarm

Integrable sample gas pump is available in 3 pump capacities N3/5/9 KPE. The FM40 flow meter installed at the sample gas outlet with a measuring range adapted to the pump capacity can be equipped with an FA-20mo flow sensor for flow monitoring. In addition, a second sample gas outlet or bypass, also optionally with flow meter and flow monitoring, can be set up for each sample gas path.

In the event of an aerosol problem, a liquid particle filter can be installed downstream the flow meter in the sample gas outlet.

Two further temperature controllers are available as extension modules for the TCU control unit, e.g. for controlling heated lines or gas sample probes. In addition, external sample gas pumps can be switched and gas sample probes can be individually back-purged.



## Example configuration CSS-VC1

- 1 Gas cooler series **ECM-1**
- 2 Option universal filter or front panel filter **FPF-0,1GF**, 0.1 µm, optional with liquid alarm **LA** or front panel filter **FPF+**, optional with integrated liquid alarm
- 3 Option 3 or 5-way-ball valve **3L/PV** or **5L/PV**
- 4 Option sample gas pump N3/5/9KPE
- 5 Option peristaltic pump **SR25.2**
- 6 Option flow meter **FM40** with flow alarm
- 7 Option flow meter **FM40**
- 8 Option liquid particle filter **CLF-5/W** or **CLF-T(SS)**

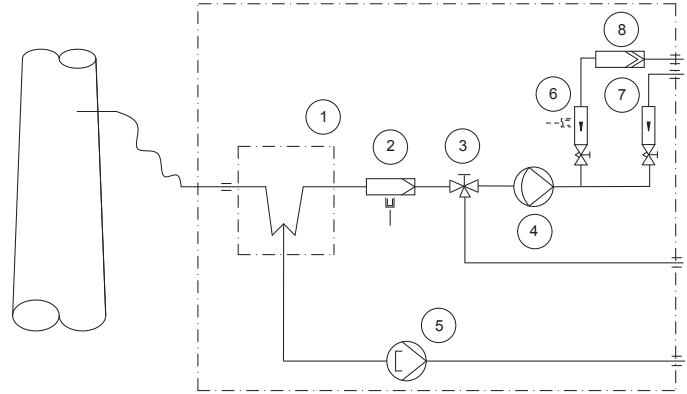

## Example configuration CSS-VC2

- 1 Gas cooler series **ECM-2**
- 2 Option universal filter or front panel filter **FPF-0,1GF**, 0.1 µm, optional with liquid alarm sensor **LA** or front panel filter **FPF-2-0,3GF**, 0.3 µm, with integrated liquid alarm sensor
- 3 Option 3 or 5-way-ball valve **3L/PV** or **5L/PV**
- 4 Option sample gas pump **N3/5/9KPE**
- 5 Option peristaltic pump **SR25.2**
- 6 Option flow meter **FM40** with flow alarm
- 7 Option flow meter **FM40**
- 8 Option liquid particle filter **CLF-5/W** or **CLF-T(SS)**

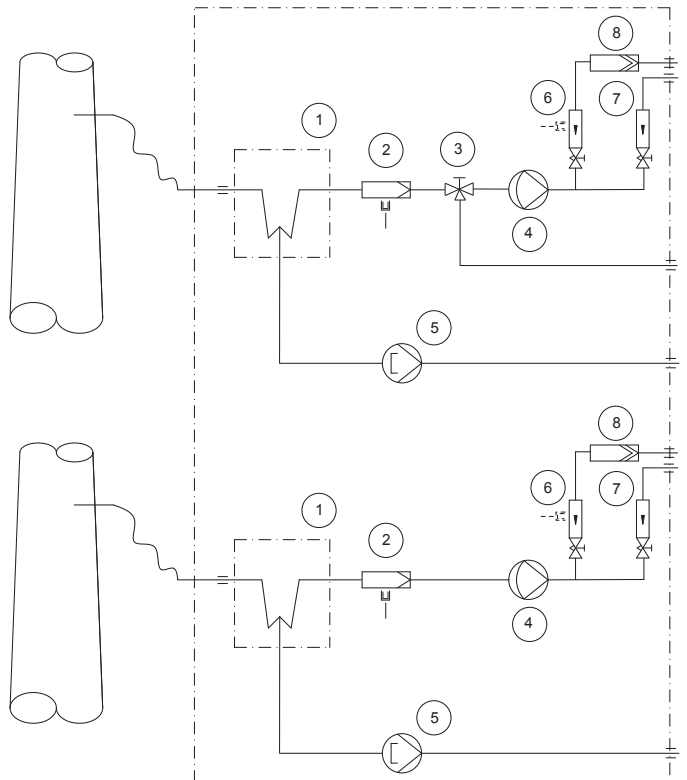

## Dimensions CSS-VC1/VC2

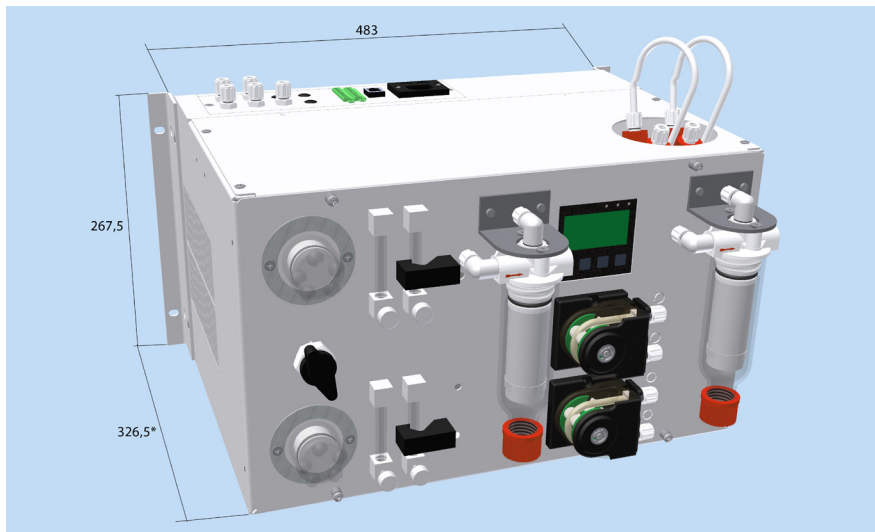

Dimensions in mm  
\* 301.5 without wall-mounting brackets

Gas Conditioning Unit Series CSS®	Version CSS-VC1	Version CSS-VC2
Part No. 230 V/50 Hz	<b>01G6050</b>	<b>01G6055</b>
Part No. 115 V/50-60 Hz	<b>01G6050a</b>	<b>01G6055a</b>
Sample outlet dew point	Range of adjustment: +2 to +7 °C [35.6 to 44.6 °F], factory setting: +5 °C [41 °]	
Dew point stability	At constant conditions < ±0.1 °C [< ±0.18 °F]	
Sample inlet temperature*	Max. 180 °C [356 °F]	
Sample inlet dew point*	Max. 80 °C [176 °F]	
Gas flow rate*	Max. 250 NI/h	Max. 2 x 150 NI/h
Ambient temperature*	+10 up to +40 °C [41 up to 104 °F]	
Storage temperature	-25 up to +65 °C [-13 up to 149 °F]	
Pressure	0.7 bar up to 1.4 bar abs.	
Total cooling capacity*	Max. 144 kJ/h	
Number of gas inlets	1	2
Number of gas outlets	1	2
Condensate outlet	1	2
Medium connections	Tube connection DN 4/6	
Material of sample-contacting parts	Heat exchanger: Duran® glass, PVDF or stainless steel 1.4571 Tubing and fittings: PTFE, PVDF Universal filter FP-2T-D: PVDF, FKM, glass, PTFE Front-panel filter FPF-0,1GF: PVDF, glass, FKM Front-panel filter FPF+: PVDF, glass, FKM Peristaltic pump SR25.2: PVDF, Novoprene Liquid particle filter CLF-5/W: PVDF, glass, FKM, PTFE Sample gas pumps N3/5/9: PVDF, PTFE, FKM Flow meter FM40: PVDF, glass, FKM, Hastelloy® C-4 Ball valve 3L/PV and 5L/PV: PVDF, FKM	
Ready for operation	Approx. 10 min.	
Power supply	230 V/50-60 Hz ±10 % or 115 V/50-60 Hz ±10 %**	
Power consumption	Max. 220 VA + max. 300 VA for the sample gas pumps	
Fuse protection	4 A t, 5 x 20 mm	
Electrical connection	Cold appliance plug with 2 m [≈ 6.6 ft] cable	
Case protection	IP20 EN 60529	
Housing protection	Sheet steel case for 19"- or wall-mounting, lacquered RAL 7032	
Equipment dimensions (H x W x D)	267.5 x 483 x 301.5 mm [≈ 10.5" x 29" x 11.9"] (portable version : 355 x 515 x 395 mm [≈ 14" x 20.3" x 15.5"])	
Electrical equipment standard	EN 61010	
Weight	Approx. 22 kg [≈ 48.5 lbs]	

\* Maximum values in the technical data must be rated in consideration of the total cooling power at 25 °C [77 °F] and an outlet dew point of 5 °C [41 °F].

\*\* 115 V/50 Hz sample gas pump also possible.

PVDF: Polyvinylidenfluoride; PVC: Polyvinylchloride; FKM: Fluroelastomer = Viton®; PPH: Polypropylene type homopolymer; PTFE: Polytetrafluoethylene  
Viton®, Duran® and Hastelloy®C-4 are registered trademarks.

Please note: NI/h and NI/min refer to the German standard DIN 1343 and are based on these standard conditions: 0 °C [32 °F], 1013 mbar.

## Options

Description	Part No.
<b>Heat Exchangers and Housing Version</b>	
Extra charge for gas connections directly at one heat exchanger	<b>01G6062</b>
Extra charge for heat exchanger ECM-1 out of glass for CSS-VC1, sample gas connections at the Jet-Stream heat exchanger	<b>93K0140</b>
Extra charge for heat exchanger ECM-1 out of stainless steel SS316Ti for CSS-VC1, sample gas connections at the Jet-Stream heat exchanger	<b>93K0160</b>
Extra charge for heat exchanger ECM-1 out of PVDF for CSS-VC1, sample gas connections at the Jet-Stream heat exchanger	<b>93K0170</b>
Extra charge for gas connections directly at two heat exchangers	<b>01G6063</b>
Extra charge for heat exchanger ECM-2 out of glass for CSS-VC2, sample gas connections at the heat exchanger	<b>97K0100</b>
Extra charge for heat exchanger ECM-2 out of stainless steel SS 316Ti for CSS-VC2, sample gas connections at the heat exchanger	<b>97K0115</b>
Extra charge for heat exchanger ECM-2 out of PVDF for CSS-VC2, sample gas connections at the heat exchanger	<b>97K0110</b>
Extra charge for gas connections of one heat exchanger in the joint plate for e.g. 19" mounting	<b>01G6060</b>
Extra charge for heat exchanger ECM-1 90° out of glass for CSS-VC1, sample gas connections in the joint plate for e.g. 19" mounting	<b>93K0150</b>
Extra charge for heat exchanger ECM-1 out of PVDF for CSS-VC1, sample gas connections in the joint plate for e.g. 19" mounting	<b>93K0170</b>
Extra charge for gas connections of two heat exchangers in the joint plate for e.g. 19" mounting	<b>01G6061</b>
Extra charge for Jet-Stream heat exchanger ECM-2 90° out of glass for CSS-VC1, sample gas connections in the joint plate, e.g. 19" mounting	<b>97K0150</b>
Extra charge for Jet-Stream heat exchanger ECM-2 out of PVDF for CSS-VC1, sample gas connections in the joint plate, e.g. 19" mounting	<b>97K0110</b>
<b>Peristaltic pumps for condensate removal (max. 2 pcs.)</b>	
Extra charge for mounting a peristaltic pump SR25.2 for condensate removal, completely flexible tubed (one per gas path necessary)	<b>01G6140</b>
<b>Filters (max. 2 pcs. front-panel filters and 2 pcs. universal filters or aerosol filters) and liquid alarm sensor</b>	
Extra charge for mounting front-panel filter FPF-0,1GF	<b>04F1000</b>

Description	Part No.
Extra charge for flow chamber LS/LA2 with flow alarm sensor at front panel filter FPF-0,1GF	03E3010
Extra charge for mounting a front panel filter FPF+	04F2100
Extra charge for a filter element for FPF+ (depending on filter element)	As requested
Extra charge for liquid alarm sensor LA3 integrated in FPF+	03E1300
Extra charge for universal filter (see data sheet 7.1)/aerosol filter CLF... (see data sheets 7.7 and 7.8)	As requested
Extra charge for mounting an universal filter/aerosol filter CLF on front plate (max. 2 pcs.)	01G6075
Extra charge for liquid alarm sensor LA1S for universal filter F.-.-D	03E3001
<b>Ball valves for test gas feeding (max. 1 pc.)</b>	
Extra charge for mounting a 3-way ball valve 3L/PV	01G9046
Extra charge for mounting a 5-way ball valve 5L/PV	01G9045
<b>Sample gas pumps (max. 2 pcs.) (only with electronic controller 01G6175)</b>	
Extra charge for preparing the installation of sample gas pumps N...KPE	01G6070
Extra charge for mounting the sample gas pump N3KPE	01G6125
Extra charge for mounting the sample gas pump N5KPE	01G6130
Extra charge for mounting the sample gas pump N9KPE	01G6135
<b>Flow meter (max. 4 pcs. in total) and flow alarm (max. 2 pcs.)</b>	
Extra charge for mounting a float-type flow meter FM40 7-70 NI/h in sample gas outlet	09F4000
Extra charge for mounting a float-type flow meter FM40 15-150 NI/h in sample gas outlet	09F4005
Extra charge for mounting a float-type flow meter FM40 25-250 NI/h in sample gas outlet	09F4010
Extra charge for mounting a float-type flow meter FM40 50-500 NI/h in sample gas outlet	09F4015
Extra charge for forked flow alarm sensor FA-20mo	02E3500
Extra charge for bypass flow meter FM40 7-70 NI/h with needle valve and sample gas outlet	01G6200
Extra charge for bypass flow meter FM40 15-150 NI/h with needle valve and sample gas outlet	01G6210
Extra charge for bypass flow meter FM40 25-250 NI/h with needle valve and sample gas outlet	01G6220
Extra charge for bypass flow meter FM40 50-500 NI/h with needle valve and sample gas outlet	01G6230
<b>Electronic controllers</b>	
Extra charge for electronic controller with collective status alarm	01G6170
Extra charge for single alarm messages (temperature, flow, liquid in the system) inclusive mA output for cooler temperature for external temperature display, factory setting: 4-20 mA (0 to 50 °C [32 to 122 °F]), on request 0-20 mA available	01G6175
<b>External additional modules (only with electronic controller 01G6175)</b>	
Extra charge for communication module (only necessary once for all extension modules of the TCU)	01B8620
Extra charge for temperature controller module (2 additional temperature controllers in TCU with 4 relays for high or low temperature monitoring) for control of solid state relays For controller parameterization, please specify in the order which M&C devices should be controlled (type of gas sample probe(s) as well as type and length of heated sample line(s)).	01B8640
Extra charge for status module for collective alarm message via 1 changeover contact relay and 1 solid state relay for switching of external sample gas pumps	01B8630
Extra charge for blowback module for programmed control of solenoid valves for blowback of gas sample probes with status monitoring (measuring/blowback), monitoring of the blowback pressure and control of the sample gas pumps (on/off)	01B8650
Extra charge for M&C bus for external modules	01G6180
<b>Carrying case (only for 19"-version)</b>	
Extra charge for carrying case for portable gas conditioning	01G6250
Extra charge for trolley system	90G0160
<b>Temperature controller for portable version (only with electronic controller 01G6175)</b>	
Extra charge for temperature controller for max. 10 m heated sample line, 230 V with PT100, with solid state relays and 7-pole plug	01G6190
<b>Anti-kink protection adapter for portable gas conditioning</b>	
Extra charge for anti-kink protection for heated sample line DN 4/6	01G9060
Extra charge for anti-kink protection for heated sample line DN 6/8	01G9061

**Order example:**

1x 01G6050 + 1 x 01G6060 + 1 x 93K0150 + 1 x 01G6140 + 1x 04F2100 + 1 x 90F0002 + 1 x 03E1300 + 1 x 03F3005 + 1 x 01G6075 + 1 x 01G6070 + 1 x 01G6130 + 1 x 09F4005 + 1 x 02E3500 + 1 x 01G6210 + 1 x 01G6175 + 1 x 01G9160 =

CSS-VC1, 230 V, with heat exchanger out of glass, sample gas connections in the joint plate, built-in peristaltic pump SR25.2, built-in front panel filter FPF+2T with integrated liquid alarm sensor LA3, aerosol filter CLF-5/W mounted on front panel, built-in sample gas pump N5KPE, flow meter FM40 15-150 NI/h and flow alarm sensor FA-20mo in the sample outlet, flow meter FM40 15-150 NI/h in the bypass, single alarm messages and mA outlet for external cooling temperature indication, temperature controller module TCU

# Application example

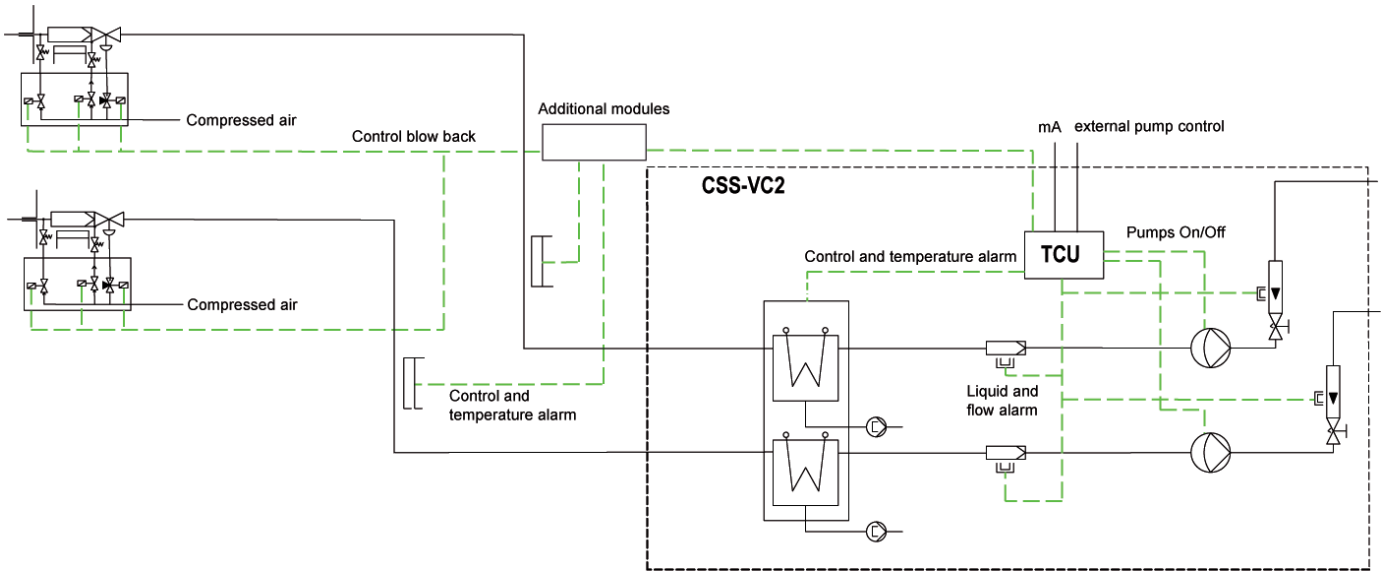

# CSS-VC with trolley system





CSS-V2

## Gas Conditioning Unit Series CSS®

Version CSS-V1 for max. 1 x 250 NI/h gas flow rate,  
version CSS-V2 for max. 2 x 150 NI/h gas flow rate,  
for 19" rack or wall-mounting

### Special Features

- **Compact, high-performance design with compressor cooler**
- **Individually configurable**
- **Completely pre-installed**
- **One or two gas paths**
- **19" rack or wall-mount housing**
- **Minimum maintenance and self-monitoring**
- **Gas outlet dew point adjustable from +2 to +7 °C [35.6 to 44.6 °F]**
- **Dew point stability < ±0.1 °C [±0.18 °F]**
- **Ready for operation in 10 minutes**
- **Light weight**
- **Maximum operational reliability**

### Application

The CSS-V1 and CSS-V2 units provide a completely pre-installed compact, high-performance sample gas conditioning system for continuous use. Due to a large number of additional options, the sample gas conditioning system can be excellently adapted to the various requirements of continuous gas analysis technology.

The compact design only requires a small amount of space. The sample gas conditioning units are ready for operation within a few minutes. The usual time-consuming acquisition of individual components and small parts and their assembly is therefore no longer necessary.

### Description

All components of the gas conditioning unit are mounted in a compact sheet steel housing.

Filter, flow meter and peristaltic pumps are built into the front panel for easy maintenance.

Depending on the version, the compressor gas cooler is equipped with one or two heat exchanger(s) made of glass, stainless steel or PVDF.

The fine filter FPF-2-0,3GF (0.3 µm filter porosity) installed downstream of the cooler provides the necessary separation of solids. The condition of the filter can be assessed from the outside.

The downstream sample gas pump is available in three different pump capacities N3/5/9 KPE.

The flow meter FM40 with the corresponding measuring range installed in the sample gas outlet can be equipped with a flow alarm sensor FA-20mo and corresponding electronic controller.

The device is equipped with a temperature alarm contact, which signals a temperature alarm in the event of a deviation of ±3 °C [±5.4 °F] from the factory-set setpoint (+5 °C [41 °F]) and switches off the sample gas pump, if present.

The resulting condensate is removed continuously via the peristaltic pump type SR25.2.

The ventilation grids in the sidewalls ensure that the equipment is sufficiently ventilated.

A liquid alarm sensor is integrated in the filter FPF-2-0,3GF to protect the downstream analyzers against liquid inrush and to increase the operating safety of the entire system. Via one or two potential-free contact(s) for the collective alarm (cooler temperature, gas flow, liquid in the filter), an alarm signal is triggered and the sample gas pump, if present, is switched off.

## Design CSS-V1

- 1 Gas cooler series ECM-1
- 2 Option front panel filter PPF-2-0,3GF, 0.3 µm filter unit with integrated liquid alarm sensor
- 3 Option sample gas pump N3/5/9KPE
- 4 Option flow meter FM40 with flow alarm
- 5 Option peristaltic pump SR25.2

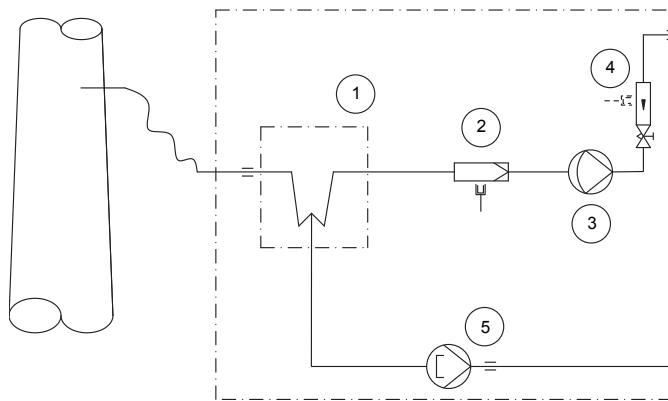

## Design CSS-V2

- 1 Gas cooler series ECM-2
- 2 Option front panel filter PPF-2-0,3GF, 0.3 µm filter unit with integrated liquid alarm sensor
- 3 Option sample gas pump N3/5/9KPE
- 4 Option flow meter FM40 with flow alarm
- 5 Option peristaltic pump SR25.2

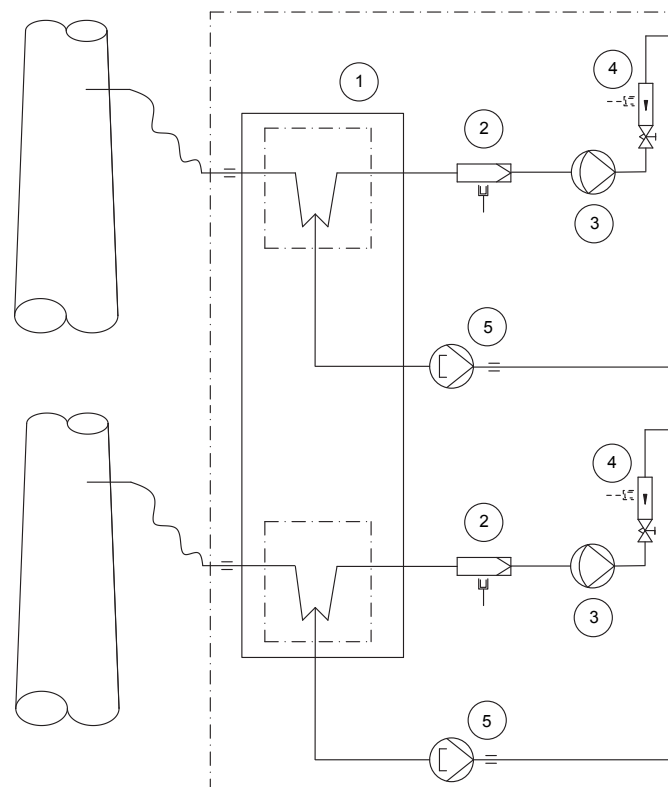

## Dimensions CSS-V1/V2

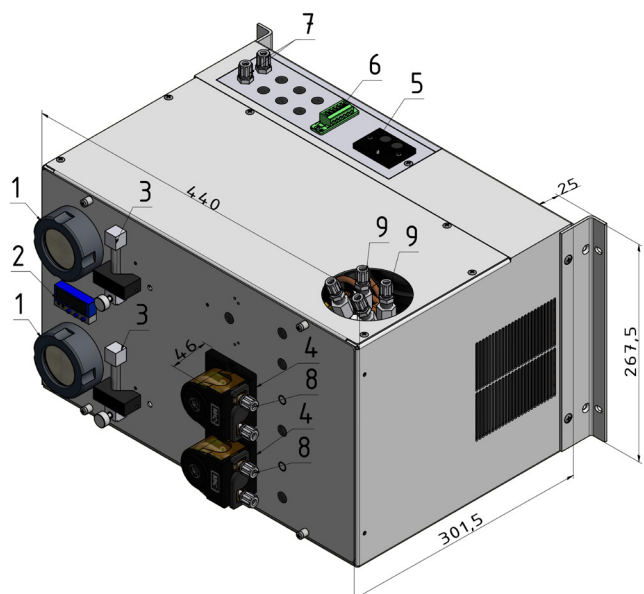

- 1 Fine filter PPF-2-0,3GF
- 2 Electronic controller
- 3 Flow meter FM40 with flow alarm sensor FA-20mo
- 4 Peristaltic pump SR25.2
- 5 Power supply
- 6 Connection collective alarm
- 7 Sample gas outlets
- 8 Condensate outlet directly at the peristaltic pump
- 9 Sample gas inlets directly at the heat exchanger

Gas Conditioning Unit Series CSS*	Version CSS-V1	Version CSS-V2
Part No. for 230 V/50 Hz version	<b>01G6010</b>	<b>01G6020</b>
Part No. for 115 V/50-60 Hz version	<b>01G6010a</b>	<b>01G6020a</b>
Sample gas outlet dew point	Range of adjustment: +2 to +7 °C [35.6 to 44.6 °F], factory setting: +5 °C [41 °F]	
Dew point stability	At constant conditions < ±0.1 °C [±0.18 °F]	
Sample gas inlet temperature	**Max. 180 °C [356 °F]	
Sample gas inlet dew point	**Max. 80 °C [176 °F]	
Gas flow rate	**Max. 250 NI/h	**Max. 2 x 150 NI/h
Ambient temperature	**+10 to +40 °C [50 to 104 °F]	
Storage temperature	-25 to +65 °C [-13 to 149 °F]	
Pressure	0.7 bar up to 1.4 bar abs.	
Total cooling capacity **	Max. 144 kJ/h	
Number of gas inlets	1	2
Number of gas outlets	1	2
Condensate outlet	1	2
Medium connections	Tube connection DN 4/6	
Material of sample-contacting parts	PVDF, Novoprene, FKM, PVC, PPH, PTFE	
Ready for operation	Approx. 10 min.	
Power supply	230 V 50-60 Hz ±10 % or 115 V 50-60 Hz ±10 % (115 V/50 Hz not with option sample gas pump)	
Power consumption	Max. 220 VA + max. 300 VA for the sample gas pump	
Fuse protection	4 A t, 5 x 20 mm	
Electrical connection	Cold appliance plug with 2 m [≈ 6.6 ft] cable	
Case protection	IP20 EN 60529	
Sheet steel housing, design	Sheet steel case for 19" rack or wall-mounting, lacquered RAL 7032	
Equipment dimensions (H x W x D)	267.5 x 483 x 301.5 mm [≈ 10.5" x 19" x 11.9"]	
Electrical equipment standard	EN 61010	
Weight	Approx. 22 kg [≈ 49 lbs]	

PVDF = Polyvinylidenfluoride

PVC = Polyvinylchloride\*

FKM = Fluor caoutchouc = Viton\*

PPH = Polypropylene hard

PTFE = Polytetrafluorethylene

\*\* Maximum values in technical data must be rated in consideration of the total cooling power at 25 °C [77 °F] and an outlet dew point of +5 °C [41 °F].

Viton\* is a registered trademark for fluorelastomere produced by DuPont, USA.

Duran\* is a registered trademark for borosilicate glass by DWK Life Sciences GmbH, Germany.

Please note: NI/h and NI/min refer to the German standard DIN 1343 and are based on these standard conditions: 0 °C [32 °F], 1013 mbar.

## Options

Description	Part No.
Extra charge for jet-stream heat exchanger ECM-1 out of Duran® glass	<b>93K0140</b>
Extra charge for jet-stream heat exchanger ECM-1 out of stainless steel SS316Ti	<b>93K0160</b>
Extra charge for jet-stream heat exchanger ECM-1 out of PVDF	<b>93K0170</b>
Extra charge for jet-stream heat exchanger ECM-2 out of Duran® glass	<b>97K0100</b>
Extra charge for jet-stream heat exchanger ECM-2 out of stainless steel SS316Ti	<b>97K0115</b>
Extra charge for jet-stream heat exchanger ECM-2 out of PVDF	<b>97K0110</b>
Extra charge for mounting the sample gas pump N3KPE (electronic controller 01G6150 additionally necessary)	<b>01G6125</b>
Extra charge for mounting the sample gas pump N5KPE (electronic controller 01G6150 additionally necessary)	<b>01G6130</b>
Extra charge for mounting the sample gas pump N9KPE (electronic controller 01G6150 additionally necessary)	<b>01G6135</b>
Extra charge for mounting a sample gas filter FPF-2-0,3GF with integrated liquid alarm sensor	<b>01G6120</b>
Extra charge for mounting a flow meter FM40 7-70 NI/h	<b>09F4000</b>
Extra charge for mounting a flow meter FM40 15-150 NI/h	<b>09F4005</b>
Extra charge for mounting a flow meter FM40 25-250 NI/h	<b>09F4010</b>
Extra charge for mounting a flow alarm sensor FA-20mo	<b>02E3500</b>
Extra charge for mounting a peristaltic pump SR25.2 for condensate removal, completely tubed	<b>01G6140</b>
Extra charge for mounting an electronic controller for max. 2 liquid alarm sensors and max. 2 forked photoelectric sensors	<b>01G6150</b>

### Order example:

1 x 01G6010 + 1 x 93K0140 + 1 x 01G6125 + 1 x 01G6120 + 1 x 09F4010 + 1 x 02E3500 + 1 x 01G6140 + 1 x 01G6150 = CSS-V1, 230 V, with heat exchanger out of glass, built-in sample gas pump N3KPE, sample gas filter FPF-2-0,3GF with integrated liquid alarm sensor, flow meter FM40 25-250 NI/h and flow alarm sensor FA-20mo, peristaltic pump SR25.2 for condensate removal and electronic controller for liquid and flow alarm sensor.



PSS-10/1

# Portable Gas Conditioning Unit Series PSS®

Version PSS-10/1 for 480 NI/h gas flow rate

## Special Features

- **Portable gas conditioning unit inside a robust aluminium-framed case**
- **Gas flow rate: max. 480 NI/h**
- **Gas outlet dew point adjustable from +2 to +15 °C [36 to 59 °F]**
- **Dew point stability  $<\pm 0.1$  °C [ $<\pm 0.18$  °F]**
- **Minimum maintenance and self-monitoring**
- **Ready for operation in 20 minutes**
- **Jet-Stream heat exchangers made of glass, other materials available**
- **Customization for special measuring tasks possible**
- **Optionally: with trolley system**

## Application

The portable gas conditioning unit PSS-10/1 is designed to carry out precise gas analyses at different locations. The entire gas conditioning unit is housed in a compact, robust aluminium-frame case to enable you to carry out your gas analyses rapidly, safely and with little maintenance work. The PSS-10/1 gas conditioning unit is suitable for variable, discontinuous use as well as for continuous operation. The components built into the PSS-10/1 gas conditioning unit are intended for "standard use". For special measuring tasks, different or additional components from our extensive product range can also be used.

## Description

The M&C PSS-10/1 gas conditioning unit is equipped with a two-stage ECP20-2 gas cooler which cools the sample gas to a constant temperature of + 5 °C [41 °F] irrespective of the ambient temperature. As soon as the operating temperature of < +8 °C [46 °F] is reached after commissioning, the gas pump N9KPE is switched on automatically by the gas cooler status contact. The SR25.2-W peristaltic pumps ensure a continuous condensate drain, enabling long-term measurements without any problems. The corresponding particle filtration is carried out by the FP-2T ultra-fine filter. All this make the portable gas conditioning unit a complete gas conditioning system for most gas analysis devices.



## Flow scheme PSS-10/1

- 1 Gas sample probe
- 2 Sample line, 3 m Viton® hose
- 3 Gas cooler ECP 20-2
- 4 Fine filter FP-2T, filter porosity 2 µm
- 5 Diaphragm pump N9KPE
- 6 Optional flow meter FM 40
- 7 Pre-filter PF2
- 8 Peristaltic pumps SR25.2-W

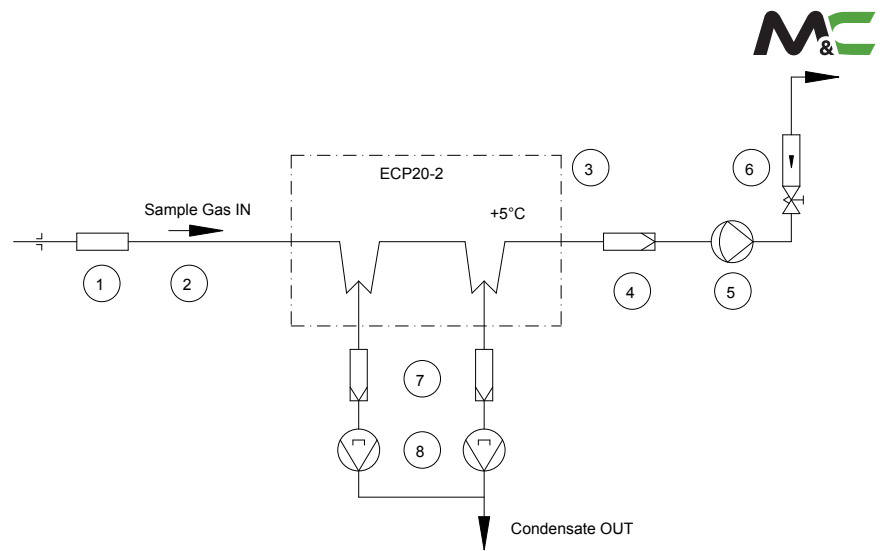

## Dimensions

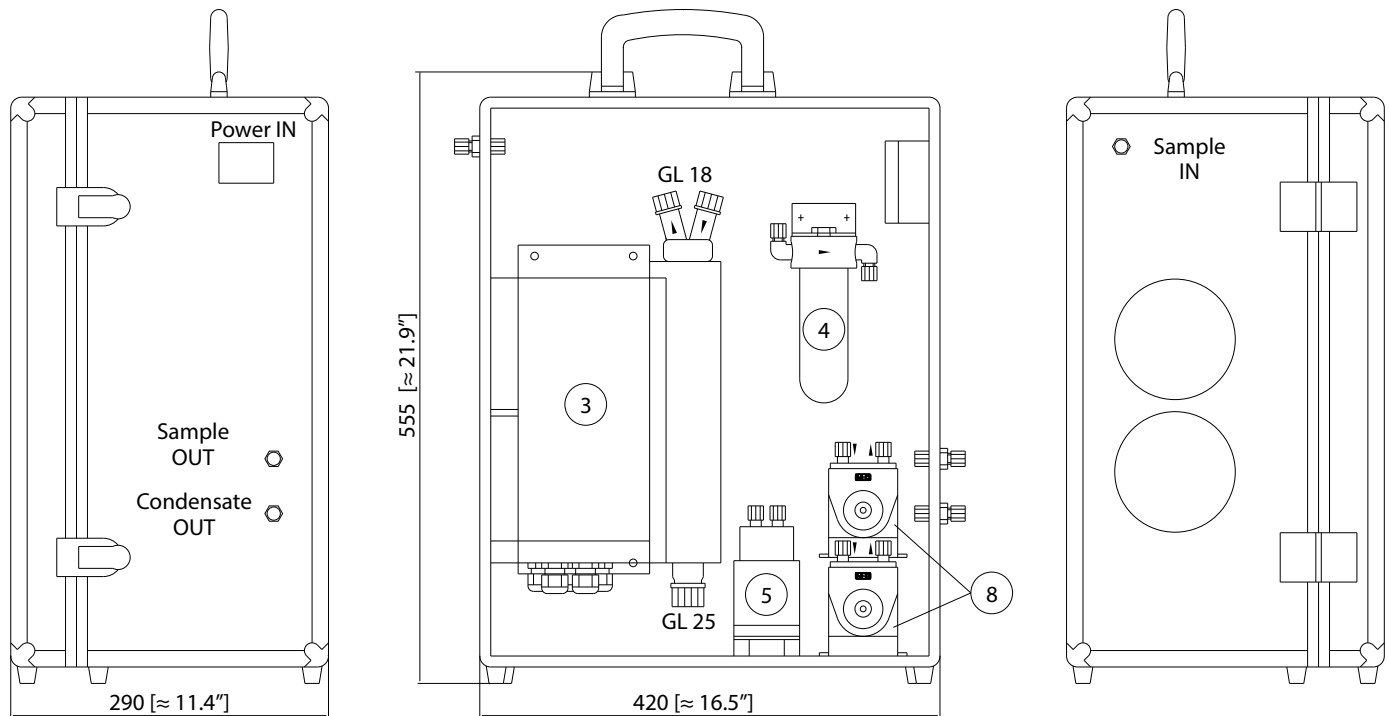

Dimensions in mm [Inches]

Gas Conditioning Unit Series PSS®	Version PSS-10/1
Part No. for 230 V/50 Hz version	01G5000
Part No. for 115 V/60 Hz version	01G5000a
Gas outlet dew point	Range of adjustment: +2 to +15 °C [36 to 59 °F], factory setting: +5 °C [41 °F]
Dew point stability	At constant conditions < ±0.1 °C [± 0.18 °F]
Gas inlet temperature*	Max. 80 °C [176 °F], optional: max. 180 °C [176 °F] with stainless steel bulkhead union
Gas inlet dew point*	Max. 80 °C [176 °F]
Gas flow rate*	Max. 480 NI/h
Ambient temperature*	+5 up to +40 °C [41 to 104 °F]
Storage temperature	-25 up to +65 °C [-13 to 149 °F]
Pressure	0.7 bar up to 1.4 bar abs.
Total cooling capacity*	Max. 80 kJ/h
Number of gas inlets	1
Number of gas outlets	1, optional: max. 4
Medium connections	Tube connection DN 4/6
Material of sample-contacting parts	Stainless steel 316Ti, glass, PVDF, Viton®, Novoprene
Ready for operation	Approx. 10 min.
Power supply	230 V/50 Hz or 115 V/60 Hz
Power consumption	Max. 350 VA; with option temperature controller and heated sample line 230 V: max.1730 VA 115 V: max. 1040 VA
Fuse protection	4 A t, 5 x 20 mm, with option temperature controller: 6.3 A t
Electrical connection	Cold appliance plug with 2 m [≈ 3.3 ft] cable
Case protection	IP20 (DIN 40050, IEC 529)
Case type	Portable aluminium framed protective case
Housing dimensions (H x W x D)	555 x 460 x 290 mm [≈ 21.9" x 18.1" x 11.4"]
Electrical equipment standard	EN 61010
Weight	Approx. 24 kg [≈ 55.1 lbs]

\* Maximum values in technical data must be rated in consideration of the total cooling capacity at 25 °C [77 °F] ambient temperature and 5 °C [41 °F] outlet dew point.

Options	Type	Part No.
Further sample gas outlet	Extra charge for parallel sample gas outlet, tubing via T-piece on lateral PVDF bulkhead fitting, DN 4/6, max. 4 pieces	01G9065
Flow meter, max. 4 pieces	FM40 7-70 NI/h air, mounted in sample gas outlet FM40 15-150 NI/h air, mounted in sample gas outlet FM40 25-250 NI/h air, mounted in sample gas outlet FM40 50-500 NI/h air, mounted in sample gas outlet	01G9070 01G9075 01G9080 01G9085
Fittings out of PVDF	Fittings out of PVDF instead of PP and 3 m [≈ 9.8 ft] Viton® sample tube DN 4/6	01G9025
Sample tube	Sample tube out of Kanthal® ø 6 mm, length 1 m [≈ 3.3 ft], sampling temperature max. 1300 °C [2372 °F]	01G9030
Liquid alarm sensor	Liquid alarm LA 1/1.4, consisting of: liquid alarm sensor LA1, controller LA1.4, filter glass F120G-D with GL connection incl. mounting/wiring. In case of condensate inrush, the sample gas pump is automatically switched off	01G9035
3-way ball valve	3L/PV-1 for switching over from test gas to sample gas, in the inlet of the sample gas conditioning unit, mounted with mounting brackets, fitting PVDF	01G9046
5-way ball valve	5L/PV-1 for switching over from test gas to sample gas, in the inlet of the sample gas conditioning unit, mounted with mounting brackets, fitting PVDF	01G9045
Electronic temperature controller for max. 12 m heated sample line 100 W/m	701 control range 0 to 200 °C [34 to 392°F], inlet PT100, power 230 V/50 Hz, Contact capacity 250 V AC max. 4 A, completely mounted incl. 7-pin plug 10 A	01G9055
Electronic temperature controller for max. 12 m heated sample line 100 W/m	701 control range 0 to 200 °C [34 to 392°F], inlet PT100, power 115 V/60 Hz, Contact capacity 250 V AC max. 4 A, completely mounted incl. 7-pin plug 10 A	01G9055a
Connecting adapter for heated sample line DN 4/6	PSS-10 connecting adapter with anti-kink protection for rigid mounting of heated sample line with replaceable PTFE tube DN 4/6, consisting of reinforced plate, Swagelok® fitting with 4 mm support sleeve, material: SS 316Ti	01G9062
Connecting adapter for heated sample line DN 6/8	PSS-10 connecting adapter with anti-kink protection for rigid mounting of heated sample line with replaceable PTFE tube DN 6/8, consisting of reinforced plate, Swagelok® fitting with 4 mm support sleeve, material: SS 316Ti	01G9063
Sample gas inlet made of stainless steel	Extra charge for gas conditioning unit series PSS® with stainless steel fittings in the sample gas inlet for 6 mm tube, material: SS316Ti	C40002
Built-in aerosol filter CLF-5	Extra charge for gas conditioning unit series PSS® with built-in aerosol filter CLF-5, fittings and mounting included	C40003
Sample gas outlet made of stainless steel	Extra charge for gas conditioning unit series PSS® with stainless steel fittings in the sample gas outlet for 6 mm tube, material: SS316Ti	C40005
Trolley system	Detachable trolley for M&C white case, as of 2014, three-stage pull-out handle with locking knob in the handle and large, ball-bearing mounted casters	90G0160

Please note: NI/h and NI/min refer to the German standard DIN 1343 and are based on these standard conditions: 0 °C [32 °F], 1013 mbar. Other versions on request.

Viton®, Teflon® are registered Trademarks of DuPont Performance elastomers. Kanthal® is a registered trademark of Sandvik Intellectual Property AB, Sweden. Swagelok® is a registered trademark of Swagelok Company, USA.



PSS5C

# Portable Gas Conditioning Unit

## Series PSS®

PSS5C, PSS5C/2 and PSS5C/3

### Special Features

- **Protection class IP42 according to EN 60529**
- **Optional measurement of the gas temperature in the outlet of the heat exchanger, 4-20 mA**
- **Optional control of cooler temperature (inside the cooling block), 4-20 mA**
- **Equipped with high-performance ECP1000C gas cooler as standard**
- **Low maintenance**
- **Gas outlet dew point adjustable from +2 to +15 °C [35.6 to 59 °F]**
- **Dew point stability <math>\pm 0.1\text{ °C}</math> [ $\pm 0.18\text{ °F}</math>]$**
- **Ready for use in less than 3 minutes**
- **Compact construction, light weight**
- **Impact-resistant case with integrated trolley system**
- **Maximum operational safety**
- **Jet-Stream heat exchangers in various materials available**
- **Can be supplied with a wide range of equipment**
- **Optional shoulder strap**

### Application

The gas conditioning system PSS5C is suitable for variable discontinuous use as well as for continuous operation.

The PSS5C complies with protection class IP42 as required by the EN 15267-4:2017 standard and includes standard-compliant gas temperature monitoring and a temperature display visible from the outside.

The entire gas conditioning system is housed in a compact and impact-resistant plastic case equipped with an integrated trolley with pull-out handle. This allows fast, low-maintenance and reliable gas analyses to be carried out at various locations with little effort. A robust shoulder strap for mounting on the case is also available as an option.

### Description

The PSS5C gas conditioning system is equipped with a high-performance Peltier gas cooler of the new series as standard.

The cooler is equipped with a Jet-Stream heat exchanger, which cools the sample gas constantly to +5 °C [41 °F], independent of the ambient temperature. As soon as the operating temperature <math>< +8\text{ °C}</math> [46 °F] is reached after commissioning, the sample gas pump N...KPE is automatically switched on by the gas cooler status contact. The peristaltic pump SR 25.2-W ensures continuous condensate removal. This also allows to easily accomplish long-term measurements with the gas conditioning system. The corresponding particle filtration is carried out by the FP-2T ultrafine filter.

For easy handling of the PSS5C, the display and function of the cooler are visible from the outside. The case needs to be opened only for maintenance.

The portable PSS5C gas conditioning system is a complete conditioning system for most gas analysis devices.

The components installed in the PSS5C are intended for "continuous use".

For special measuring tasks, additional or other components from our extensive product range can also be used.

## Gas flow diagram PSS5C

- 1 Gas sample probe
- 2 Sample line, 3 m PVC hose
- 3 Peltier gas cooler with temperature alarm (TIAHL)
- 4 Fine filter FP-2T, filter porosity 2  $\mu\text{m}$
- 5 Sample gas pump
- 6 Peristaltic pump SR25.2-W

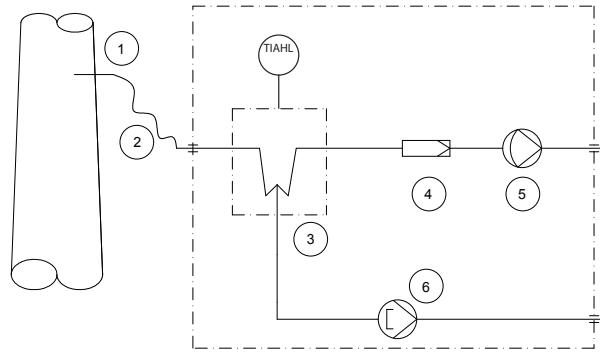

## Gas flow diagram PSS5C/2

- 1 Gas sample probe
- 2 Sample line, 3 m PVC hose
- 3 Peltier gas cooler with temperature alarm (TIAHL)
- 4 Fine filter FP-2T, filter porosity 2  $\mu\text{m}$
- 5 Sample gas pump
- 6 Peristaltic pumps 2 x SR25.2-W

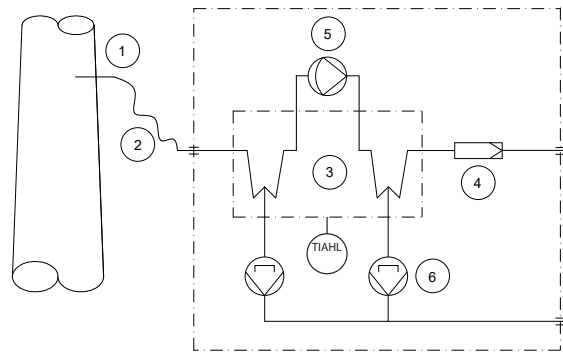

## Dimensions

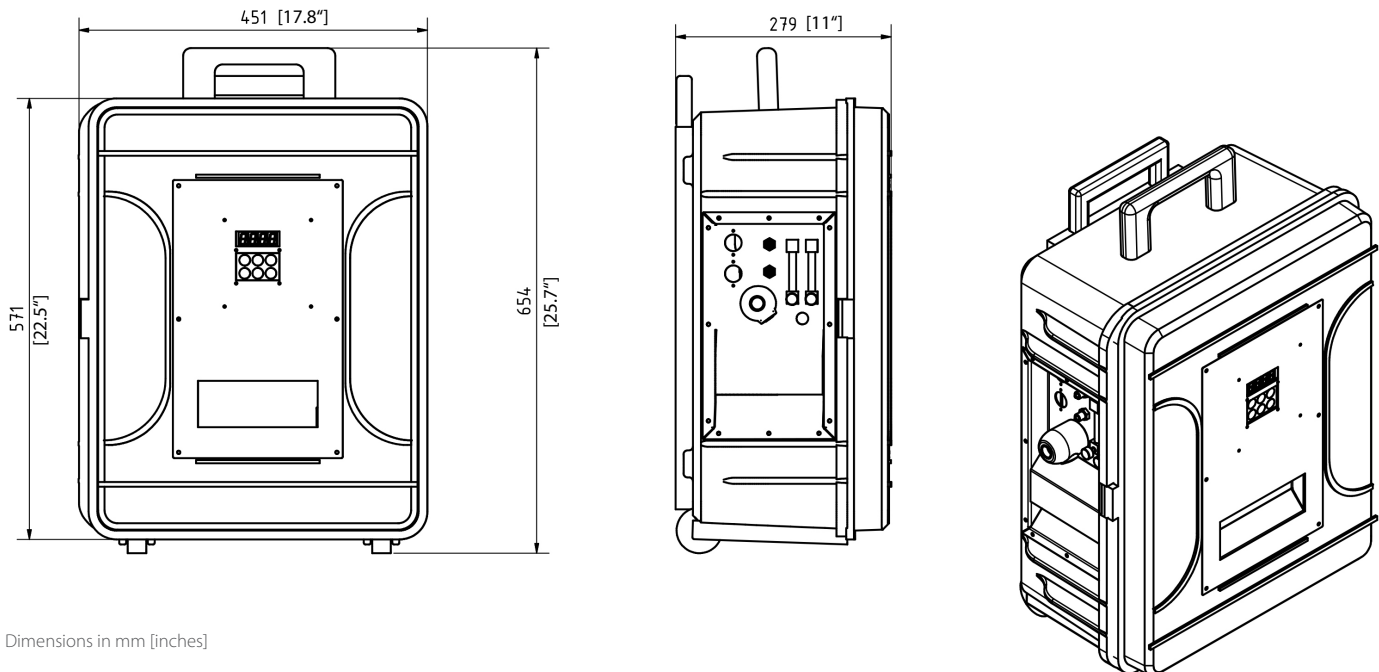

Dimensions in mm [inches]

## Technical Data

Gas Conditioning Unit Series PSS*	Version PSS5C	Version PSS5C/2	Version PSS5C/3
Part No.	<b>01G4000(a)**</b>	<b>01G4250</b>	<b>01G4500(a)**</b>
Sample outlet dew point	Range of adjustment: +2 to +15 °C [35 to 59 °F], factory setting: +5 °C [41 °F]		
Dew point stability sample outlet	At constant conditions < ±0.1 °C [±0.18 °F]		
Sample inlet temperature	*Max. 80 °C [176 °F] optional: *max.180 °C [356 °F] with stainless steel bulkhead union		
Sample inlet water vapour saturation	*Max. 80 °C [176 °F]		
Gas flow rate heat exchanger	*Max. 150 NI/h	*Max. 150 NI/h per heat exchanger	*Max. 350 NI/h
Ambient temperature	*+5 to +40 °C [41 to 104 °F]		
Storage temperature	-25 to +65 °C [-13 to 149 °F]		
Pressure	0.7 bar up to 1.4 bar abs.		
Total cooling capacity	*Max. 80 kJ/h		
Number of gas inlets	1		
Number of gas outlets	1, optional: max. 2		
Medium connections	Tube connections 4/6 mm, material: PVDF		
Material of sample contacting parts	SS316Ti, glass, PVDF, PTFE, Novoprene		
Ready for operation	Approx. 3 min.		
Power supply	230 V AC ±10 %, 50/60 Hz or Part No. with (a)**: 115 V AC ±10 %, 60 Hz		
Power consumption	Max. 240 VA; with option temperature controller and heated sample line 230 V: max. 1620 VA, 115 V: max. 920 VA		
Fuse protection	4 A t, 5 x 20 mm, with option temperature controller: 10 A t		
Electrical connection	2 m [≈ 6.6 ft] long cable		
Case protection	IP42 EN 60529		
Housing	Impact-resistant case with integrated trolley system and pull-out handle		
Housing color	Black		
Housing dimensions (W x H x D)	451 x 654 x 279 mm [≈ 17.8" x 25.7" x 11"] with casters and handle		
Electrical equipment standard	EN 61010		
Weight w/o options	Approx. 18.5 kg [≈ 40.8 lbs]	Approx. 19.2 kg [≈ 42.3 lbs]	Approx. 18.9 kg [≈ 41.7 lbs]

\* Maximum values in technical data must be rated in consideration of total cooling capacity at 25 °C [77 °F] ambient temperature and 5 °C [41 °F] outlet dew point.

\*\* (a) is an addition to the Part No. for 115 V versions.

PTFE = Polytetrafluoroethylene (Teflon®), PVDF = Polyvinylidenfluoride  
Teflon® is a registered trademark used by DuPont Performance Elastomers, USA.

Please note: NI/h and NI/min refer to the German standard DIN 1343 and are based on these standard conditions: 0 °C [32 °F], 1013 mbar.

Other versions on request.

### Option: Shoulder strap for mounting on the PSS5C case



Options	Type	Part No.
Sample gas pump N5KPE, replacement	Extra charge for replacing the standard N3KPE by the N5KPE	01G9090
Sample gas pump N9KPE, replacement	Extra charge for replacing the standard N3KPE by the N9KPE	01G9095
Flow meter including sample gas outlet, max. 2 pieces	FM40 7-70 NI/h air	01G9072
	FM40 15-150 NI/h air	01G9077
	FM40 25-250 NI/h air	01G9082
	FM40 50-500 NI/h air	01G9087
Further sample gas outlet w/o flow meter	Parallel sample gas outlet, tubing via T-piece on lateral PVDF bulkhead fitting, DN 4/6, max. 1 piece	01G9065
Sample tube	Sample tube out of Kanthal® ø 6 mm, length: 1 m, sampling temperature: max. 1300 °C [2372 °F]	01G9030
3-way ball valve	3L/PV-1 for switching over from test gas to sample gas in the inlet of the sample gas conditioning unit, mounted with mounting brackets, fitting PVDF	01G9046
5-way ball valve	5L/PV-1 for switching over from test gas to sample gas in the inlet of the sample gas conditioning unit, mounted with mounting brackets, fitting PVDF	01G9045
Needle valve	Needle valve in the bypass of the sample gas pump type N3/N5/N9 for pressureless control, with PVDF screw connections, angle bracket and assembly	01G9050
Electronic temperature controller for max. 12 m [≈ 39.4 ft] (230 V) or max. 6 m [≈ 19.7 ft] (115 V) heated sample line 100 W/m for PT100	701 control range: 0 to 200 °C [32 to 392 °F], input PT100, power: 230 V 50/60 Hz (Part No. 01G9055) or 115 V 50/60 Hz (Part No. 01G9055a), contact capacity: 250 V AC max. 10 A, completely mounted incl. 7-pin plug 10 A	01G9055(a)
Electronic temperature controller for max. 12 m [≈ 39.4 ft] (230 V) or max. 6 m [≈ 19.7 ft] (115 V) heated sample line 100 W/m for thermocouple Ni-CrNi	701 control range: 0 to 200 °C [32 to 392 °F], input thermocouple Ni-CrNi, power: 230 V 50/60 Hz (Part No. 01B8245) or 115 V 50/60 Hz (Part No. 01B8245a), contact capacity: 250 V AC max. 10 A, completely mounted incl. 7-pin plug 10 A	01B8245(a)
Connecting adapter DN 4/6 for heated sample line	PSS5C connecting adapter with anti-kink protection for rigid mounting of heated sample line with replaceable PTFE tube DN 4/6, consisting of special Swagelok fitting with 4 mm cartridge, material: SS316Ti	01G9060
Connecting adapter DN 6/8 for heated sample line	PSS5C connecting adapter with anti-kink protection for rigid mounting of heated sample line with replaceable PTFE tube DN 6/8, consisting of special Swagelok fitting with 6 mm support sleeve, material: SS316Ti	01G9061
Analog output	Analog output of the sample gas cooler temperature at the PSS5C case with connection socket, mA output for PSS5C 0/4 to 20 mA, galvanically isolated, load: 500 Ohm	01G9010
mA output	Thermocouple type K for temperature measurement in the heat exchanger with 4-20 mA output for -10 to 50 °C [14 to 122 °F], load 180 Ohm	01K9250
Liquid alarm detection	Liquid alarm detection inside the PSS5C case incl. switch-off function for the sample gas pump, liquid alarm sensor type LA1S, for conductive media, completely wired, evaluation via front display	01G9015
Sample gas inlet made of stainless steel	Extra charge for gas conditioning unit series PSS® with stainless steel fittings in the sample gas inlet for 6 mm tube, material: SS316Ti	C40002
Built-in aerosol filter CLF-5	Extra charge for gas conditioning unit series PSS® with built-in aerosol filter CLF-5, fittings and mounting included	C40003
Sample gas outlet made of stainless steel	Extra charge for gas conditioning unit series PSS® with stainless steel fittings in the sample gas outlet for 6 mm tube, material: SS316Ti	C40005
Shoulder strap for mounting on the PSS5C case	Padded and adjustable shoulder strap made of robust polyester material for mounting on the PSS5C case.	90G0270



# Portable Gas Conditioning Unit

## Series PSS®

Version PSS5 for 150 NI/h gas flow rate

Version PSS5/3 für 350 NI/h gas flow rate

### Special Features

- Low maintenance and self-monitoring
- Gas outlet dew point adjustable from +2 to +15 °C [35.6 to 59 °F]
- Dew point stability < ±0.1 °C [±0.18 °F]
- Ready for operation in approx. 10 minutes
- Compact construction
- Light weight
- Trolley system
- Optimum reliability
- Jet Stream heat exchangers in various materials available
- Universal equipment possible

### Application

The portable M&C gas conditioning units PSS5 and PSS5/3 are designed for all those who need to perform accurate gas analysis at different locations. The entire gas conditioning system is housed in a compact and robust aluminium framed case, for carrying out your gas analysis quickly, with low maintenance requirements and with maximum operational reliability.

The PSS5 and PSS5/3 gas conditioning units are suitable for variable, discontinuous use as well as for continuous operation. The components built into the gas conditioning units are intended for "standard use".

For special measuring tasks, additional or different components from our extensive product range can also be used.

### Description

The PSS5 and PSS5/3 gas conditioning units are equipped with a gas cooler from the ECP® series with a Jet-Stream heat exchanger which cools down the sample gas to constant +5 °C [41 °F] independent of the ambient temperature. As soon as the operating temperature of < +8 °C [46.4 °F] is reached after the start-up, the sample gas pump N3 KPE or N9 KPE is switched on automatically via the status contact of the gas cooler. The SR25.2-W peristaltic pump ensures a constant condensate removal which makes a long-term measurement possible without any problems. The corresponding particle filtration is carried out by a 2 µm filter type FP-2T.

This makes the portable gas conditioning system a complete conditioning system for most gas analysis equipment.

## PSS5 and PSS5/3 Design



- 1 Gas sample probe
- 2 Sample line, 3 m [ $\approx$  9.8 ft] PVC tubing
- 3 Gas cooler ECP 1000 or ECP 3000
- 4 Fine filter FP-2T, filter porosity 2  $\mu$ m
- 5 Gas diaphragm pump N3 KPE or N9 KPE
- 6 Pre-filter PF2
- 7 Peristaltic pump SR25.2-W

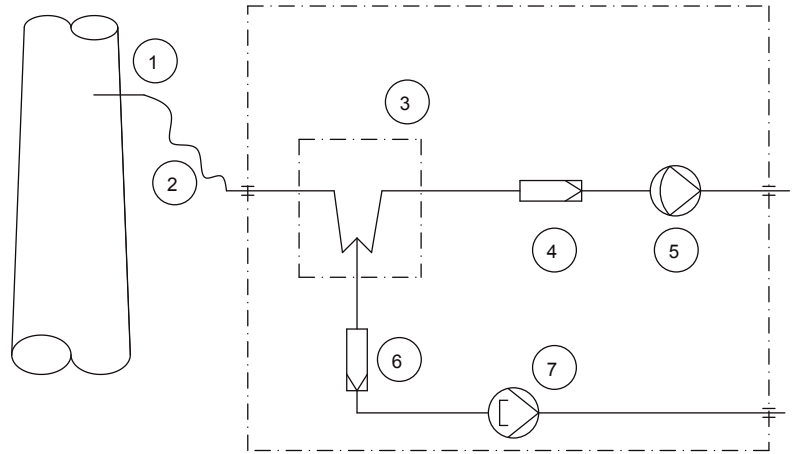

## Dimensions

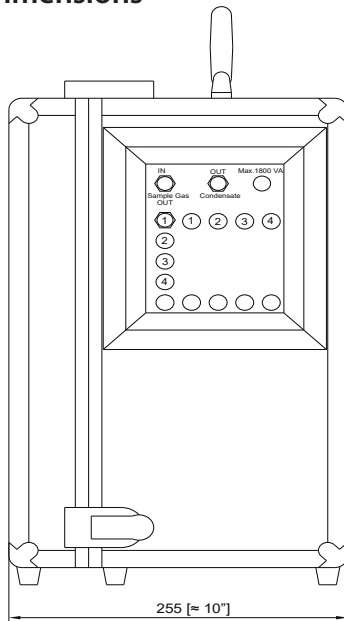

Dimensions in mm [Inches]

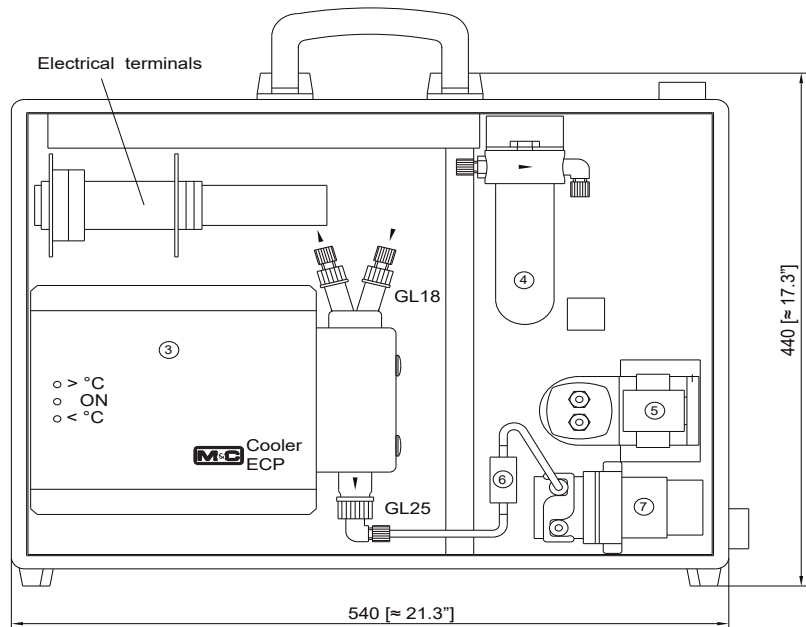

## PSS5 with Trolley System





## Technical Data

Gas Conditioning Unit Series PSS®	Version PSS5	Version PSS5/3
Part No. for 230 V/50 Hz version	01G1100	01G1500
Part No. for 115 V/60 Hz version	01G1100a	01G1500a
Gas outlet dew point	Range of adjustment: +2 to +15 °C [35.6 to 59 °F], factory setting: +5 °C [41 °F]	
Gas outlet dew point stability	At constant conditions < ±0.1 °C [±0.18 °F]	
Gas inlet temperature	Max. 80 °C* [176 °F*], optional: max. 180 °C* [356 °F*] with stainless steel bulkhead union	
Gas inlet water vapor saturation	Max. 80 °C* [176 °F*]	
Gas flow rate	Max. 150 NI/h*	Max. 350 NI/h*
Ambient temperature	+5 to +40 °C* [41 to 104 °F*]	
Storage temperature	-25 to +65 °C [-4 to 149 °F]	
Pressure	0.7 to 1.4 bar abs.	
Total cooling capacity	Max. 50 kJ/h*	Max. 90 kJ/h*
Number of gas inlets	1	
Number of gas outlets	1, optional: max. 4	
Medium connections	Tube connection DN 4/6	
Material of sample contacting parts	Stainless steel, glass, PPH, PVC, PVDF, PTFE, Novoprene®, optional: Viton® for gas sample line (Part No. 01G9025)	
Ready for operation	Approx. 10 min	
Power supply	230 V/50 Hz or 115 V/60 Hz	
Power consumption	Max. 240 VA; with option temperature controller and heated sample line 230 V: max. 1620 VA, 115 V: max. 920 VA	
Fuse protection	4 A t, 5 x 20 mm, with option temperature controller: 10 A t	
Electrical connection	Cold appliance plug with 2 m [≈ 6.6 ft] cable	
Case protection	IP20 EN 60529	
Case type	Portable aluminium framed protective case	
Case dimensions (H x W x D)	440 x 540 x 255 mm [≈ 17.3" x 21.3" x 10"]	
Electrical equipment standard	EN 61010	
Weight without options	Approx. 17 kg [≈ 37.5 lbs]	Approx. 17.7 kg [≈ 39 lbs]

Options	Type	Part No
Further sample gas outlet	Parallel sample gas outlet, tubing via T-piece on lateral PVDF bulkhead fitting, DN 4/6, max. 4 pieces	01G9065
Flow meter, max. 4 pieces	FM40 7-70 NI/h air, mounted in sample gas outlet FM40 15-150 NI/h air, mounted in sample gas outlet FM40 25-250 NI/h air, mounted in sample gas outlet FM40 50-500 NI/h air, mounted in sample gas outlet	01G9070 01G9075 01G9080 01G9085
Fittings out of PVDF	Fittings out of PVDF instead of PP and 3 m Viton® sample tube DN 4/6	01G9025
Sample tube	Sample tube out of Kanthal® ø 6 mm, length 1 m, sampling temperature max. 1300 °C [2372 °F]	01G9030
Liquid alarm	Liquid alarm LA 1/1.4, consisting of: liquid alarm sensor LA1, controller LA1.4, filter glass F120G-D with GL connection incl. moutage/wiring. In case of condensate inrush, the sample gas pump is automatically switched off.	01G9035
3-way ball valve	3L/PV-1 for switching over from test gas to sample gas, in the inlet of the sample gas conditioning unit, mounted with mounting brackets, fittings PVDF	01G9046
5-way ball valve	5L/PV-1 for switching over from test gas to sample gas, in the inlet of the sample gas conditioning unit, mounted with mounting brackets, fitting PVDF	01G9045
Electronic temperature controller for max. 12 m [≈ 39.4 ft] heated sample line 100 W/m	701 control range 0 to 200 °C [32 to 392 °F], inlet PT100, power 230 V/50 Hz, Contact capacity 250 V AC max. 10 A, completely mounted incl. 7-pin plug 10 A	01G9055
Electronic temperature controller for max. 6 m [≈ 19.7 ft] heated sample line 100 W/m	701 control range 0 to 200 °C [32 to 392 °F], inlet PT100, power 115 V/60 Hz, Contact capacity 250 V AC max. 10 A, completely mounted incl. 7-pin plug 10 A	01G9055a
Connecting adapter DN 4/6 for heated sample line	PSS5 connecting adapter with anti-kink protection adapter for rigid mounting of heated sample gas lines with replaceable PTFE hose DN 4/6, consisting of: Swagelok fitting and union nut, incl. 4 mm support sleeve, material: SS 316 Ti	01G9060
Connecting adapter DN 6/8 for heated sample line	PSS5 connecting adapter with anti-kink protection adapter for rigid mounting of heated sample gas lines with replaceable PTFE hose DN 6/8, consisting of: Swagelok fitting and union nut, incl. 6 mm support sleeve, material: SS 1.4571 Ti	01G9061
Trolley system	Detachable trolley for M&C white case, as of 2014, three-stage pull-out handle with locking knob in the handle and large, ball-bearing mounted casters	90G0160

PPH = Polypropylene  
 PTFE = Polytetrafluoroethylene (Teflon®)  
 PVC = Polyvinylchloride  
 PVDF = Polyvinylidenfluoride  
 Viton®, Teflon® are registered Trademarks of DuPont Performance elastomers

\* Maximum values in technical data must be rated in consideration of total cooling capacity at 25 °C [77 °F] ambient temperature and 5 °C [41 °F] outlet dew point. Other versions on request.



SS-5

## Gas Conditioning Unit Series PSS®

Version SS-5, SS-5/3 plate-mounted unit,  
universally equipped for 150 or 350 NI/h gas flow rate

### Special Features

- **Minimum maintenance and self-monitoring**
- **Outlet dew point adjustable from +2 to 15 °C [35.6 to 59 °F]**
- **Dew point stability  $\pm 0.1$  °C [ $\pm 0.18$  °F]**
- **Ready for operation in 10 minutes**
- **Compact design**
- **Maximum reliability**
- **Jet-Stream heat exchangers available in various standard materials**
- **Universal equipment possible**

### Application

This unit mounted on an aluminium plate provides a completely pre-installed sample gas conditioning system for continuous use that can be excellently integrated within gas analysis systems.

Its compact design only takes up little space. The SS-5 units are ready for operation in a few minutes. This makes time-consuming procurement of individual components and small parts as well as their assembly superfluous. Typical application examples for the SS-5 or SS-5/3 units are flue gas and process gas conditioning.

For special problems, such as aerosols, various solvents, explosive gases or installation areas in Ex zones, additional or other components from our extensive product range can of course also be provided.

### Description

The M&C SS-5 gas conditioning unit is equipped with an ECP... gas cooler which cools the sample gas to constant +5 °C [41 °F] independent of the ambient temperature.

As soon as the operating temperature of < +8 °C [46 °F] is reached after the start-up, the gas pump N...KPE is automatically switched on via the status contact of the gas cooler.

The SR 25.1 peristaltic pump ensures a constant condensate removal, which makes a long-term measurement possible without any problems.

The corresponding particle filtration is carried out by the ultra-fine filter type FP-2T. This makes the SS-5 unit a complete gas conditioning system suitable for most analyzers.

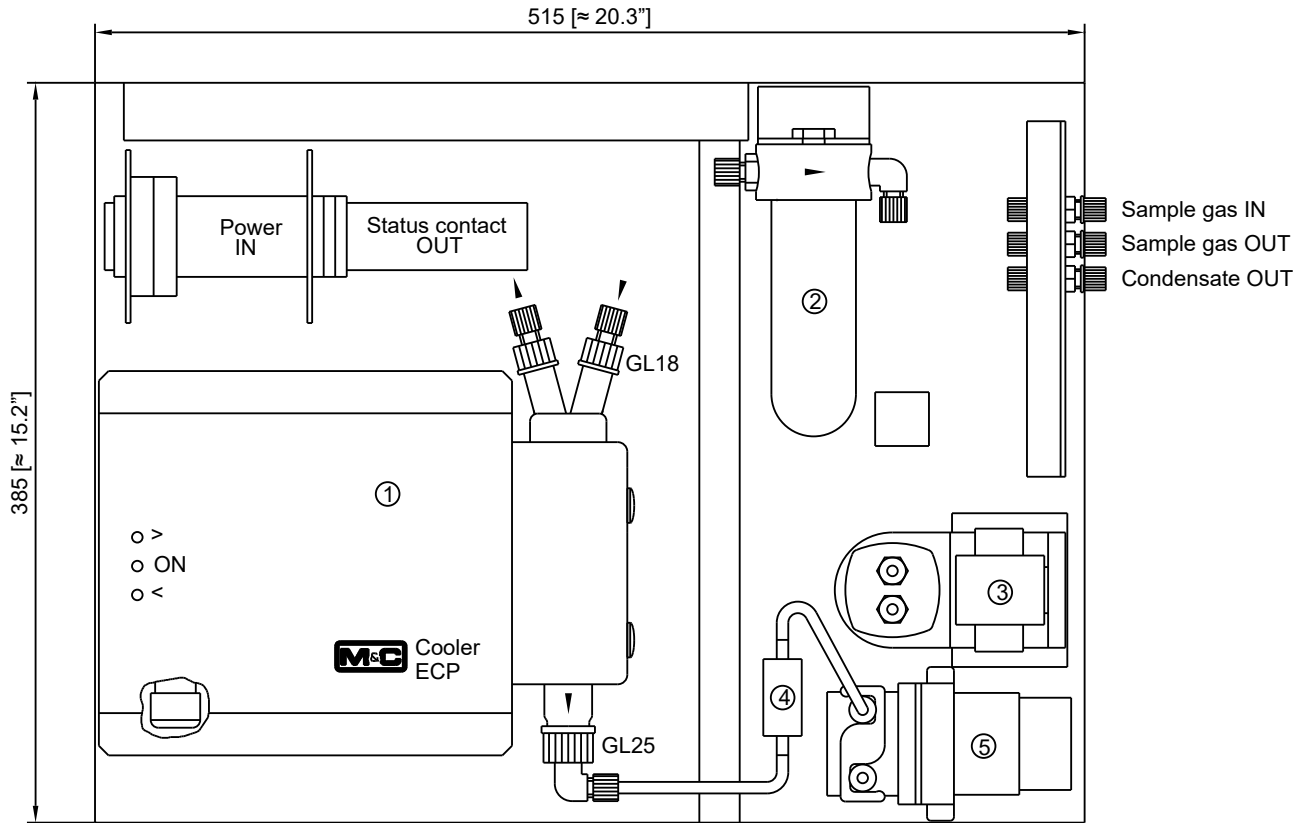

Dimensions in mm [Inches]

Flow scheme SS-5 and SS-5/3

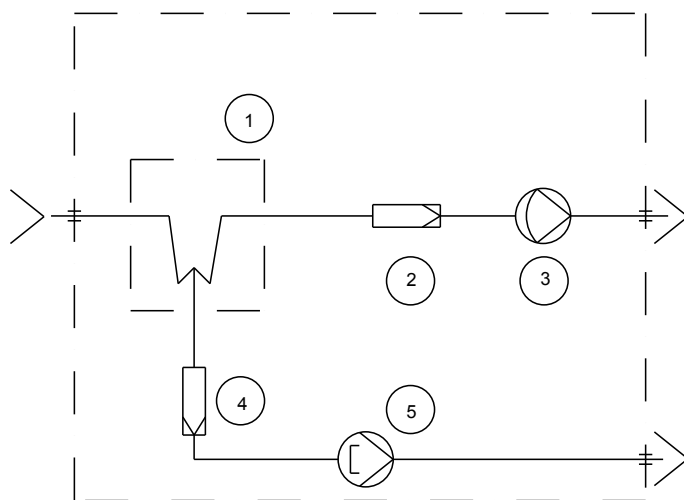

- 1 Gas cooler ECP1000 or ECP 3000
- 2 Fine filter FP-2T, filter porosity 2 μm
- 3 Gas diaphragm pump N3KPE or N9KPE
- 4 Pre-filter PF2
- 5 Peristaltic pump SR25.1

## Technical Data

Gas Conditioning Unit Series PSS®	Version SS-5	Version SS-5/3
Part No. for 230 V/50 Hz version	03G5000	03G5500
Part No. for 115 V/60 Hz version	03G5000a	03G5500a
Sample outlet dew point	Range of adjustment: +2 to +15 °C [34 to 59 °F], factory setting: +5 °C [41 °F]	
Dew point stability	At constant conditions < ±0.1 °C [±0.18 °F]	
Sample inlet temperature*	Max. +80 °C [176 °F] optional: max. 180 °C [356 °F] with stainless steel bulkhead union	
Sample inlet dew point*	Max. +80 °C [176 °F]	
Gas flow rate*	Max. 150 NI/h	Max. 350 NI/h
Ambient temperature*	+5 up to +40 °C [41 up to 104 °F]	
Storage temperature	-25 up to +65 °C [-13 up to 149 °F]	
Pressure	0.7 bar up to 1.4 bar abs.	
Total cooling capacity at 25 °C [77 °F] ambient	Max. 50 kJ/h	Max. 90 kJ/h
Number of gas inlets	1	
Number of gas outlets	1 optional: max. 4	
Medium connections	Tube connection 4/6 mm	
Material of sample contacting parts	Stainless steel, glass, PPH, PVC, PVDF, PTFE, Novoprene	
Ready for operation	Approx. 10 min.	
Power supply	230 V/50 Hz or 115 V/60 Hz	
Power consumption	Max. 240 VA	
Fuse protection	4 A t, 5 x 20 mm, with option temperature controller: 10 A t	
Electrical connection	Terminals 4 mm <sup>2</sup>	
Case protection	IP20 (DIN 40050, IEC 529)	
Electrical equipment standard	EN 61010	
Mounting version	Aluminium mounting plate for wall-mounting	
Dimensions (W x H x D)	515 x 385 x 190 mm [≈ 20.3" x 15.2" x 7.5"]	
Weight	Approx. 15.5 kg [≈ 34.2 lbs]	Approx. 17.0 kg [≈ 37.5 lbs]

\* Maximum values in technical data must be rated in consideration of the total cooling capacity at 25 °C [77 °F] ambient temperature and 5 °C [41 °F] outlet dew point. Please note: NI/h and NI/min refer to the German standard DIN 1343 and are based on these standard conditions: 0 °C [32 °F], 1013 mbar.

PPH = Polypropylene, PTFE = Polytetrafluoroethylene (= Teflon®), PVDF = Polyvinylidenfluoride, PVC = Polyvinylchloride  
Teflon® a registered trademark of DuPont Performance Elastomers, USA.

## Options

	Alternatively	Part number
Flow meter FM40 mounted in sample gas outlet: max. 4 pcs.	7-70 NI/h air 15-150 NI/h air 25-250 NI/h air 50-500 NI/h air max. 4 pcs.	01G9070 01G9075 01G9080 01G9085
Temperature controller for heated sample line 230 V/50 Hz:	Range of control: 0 to 200 °C [32 to 392 °F], input PT100, 230 V, max. 6 A, max. length of the sample line: 20 m	01G9055
Temperature controller for heated sample line 115 V/60 Hz:	Range of control: 0 to 200 °C [32 to 392 °F], input PT100, 115 V, max. 6 A, max. length of the sample line: 10 m	01G9055a
Liquid alarm type	LA 1/1.4	01G9035
5-way ball valve type	5L/PV-1	01G9045