

# Product Group Filters.

Product Category Gas Conditioning.





CLF-5

## Liquid Particle Filter Series CLF®

Version CLF-5, CLF-5/W for the separation of aerosols from gases

### Special Features

- **High retention rate of 99.9999 % for particles > 0.1 µm**
- **Also with integrated hydrophobic diaphragm for analyzer protection**
- **Condition of filter element visible from outside**
- **Easy change of filter element**
- **Wall-mounting**

### Application

The M&C liquid particle filters CLF-5 and CLF-5/W are suitable for the separation of all types of fine liquid particles and are recommended for sample gases with an acid dew point above 100 °C [212 °F], for example for flue gas measurements of heavy oil or hard coal combustion plants.

The filter separates aerosols (finest liquid droplets) which still have passed the sample gas cooler. After sample conditioning, the CLF-5 is best positioned directly in front of the flow meter of the analyzer.

To increase system reliability, the CLF-5/W version is equipped with an integrated hydrophobic protective membrane.

### Description

The filter element of the M&C liquid particle filter CLF-5 has a two-layer construction and the flow direction is from the inside to the outside. The inner, very fine layer binds the fine liquid particles suspended in the gas and forwards them with the gas flow to the outer, coarser layer. On their way through the filter element, the very fine liquid particles accumulate to form droplets. The vertical flow direction, together with gravity, supports the dripping of the liquid into the filter glass.

The filter element retains its efficiency even when completely saturated with liquid. Without being contaminated by solid particles, its service life is almost unlimited. The pressed microfibers are joined with PVDF binder to avoid the influence on sample gas. The CLF-5/W version is equipped with a breakthrough stop for water and water-like

liquids. The hydrophobic protective membrane integrated in the filter element holder prevents the liquid from breaking through to the filter outlet in the event of a malfunction.

Due to the glass filter body, the condition of the filter is immediately visible from the outside without opening the filter assembly.

The GL 25 connection enables automatic emptying of the liquid by means of an optional SR25.2.W external peristaltic pump.

No tools are required for element replacement. The optimum positioning of the O-ring always ensures a secure sealing between the filter body and the filter head. Filter inlet and outlet can be rotated 180° on the wall mounting, allowing flexible adaptation to local conditions during installation.

**Handle with care! Danger of acid burns!**

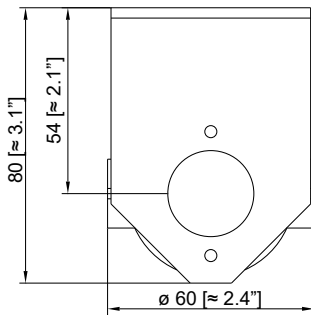
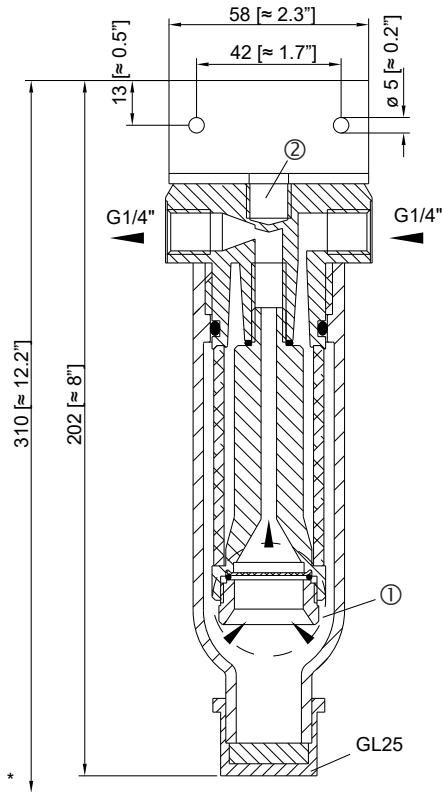

\* Dimensions required for dismounting 310 mm [≈ 12.2"]

Dimensions in mm [Inches]

- ① Protective hydrophobic diaphragm unit only with version CLF-5/W.
- ② On request the G 1/4" i thread connection can be used as a second gas outlet through a  $\varnothing 5$  mm [≈  $\varnothing 0.2$ ] bore hole.

Technical Data

Liquid particle filter	CLF-5	CLF-5/W
Part No.	03F3000	03F3005
Option: water stop	None	Yes
Gas flow	Max. 300 NI/h	Max. 200 NI/h
Gas pressure	0.2 to 2 bar abs. $\Delta P$ max. 1.0 bar	0.3 to 2 bar abs. $\Delta P$ max. 0.5 bar
Differential pressure with a new filter element, with air, 20 °C [68 °F]	3 6 10 mbar 100 200 300	17 35 mbar 100 200
Sample temperature	Max. +80 °C [176 °F]	
Ambient temperature	0 to +60 °C [32 to 140 °F]	
Storage temperature	-25 to +80 °C [-13 to 176 °F]	
Filter element/retention rate	2-layers CLF-5/99.9999 % for particles > 0.1 $\mu$ m	
Filter dead volume	70 cm <sup>3</sup>	
Volume capacity for liquid	20 ml	
Material of sample contacting parts	PVDF, glass, FKM	PVDF, glass, FKM, PTFE, Polyester
Sample gas-/drain connection	G 1/4" i DIN ISO 228/1/GL 25 cap	
Type of mounting	Wall-mounting	
Weight	Approx. 0.3 kg [≈ 0.7 lb]	

Please note: NI/h and NI/min refer to the German standard DIN 1343 and are based on these standard conditions: 0 °C [32 °F], 1013 mbar.



CLF-T

## Liquid Particle Filter Series CLF®

Versions CLF-T, CLF-SS made out of special materials, for the separation of aerosols from gases

### Special Features

- High retention rate of 99.99 % for particles > 0.1 µm
- High chemical resistance of type CLF-T
- Type CLF-SS suitable for high pressure applications
- Type CLF-T: filter element condition visible from the outside
- Easy change of filter element
- With bracket for wall-mounting

### Application

The M&C liquid particle filter CLF® is suitable for the separation of fine liquid particles of all kinds. The CLF-T is recommended for sample gases with a sample gas temperature of up to 100 °C [212 °F] and the CLF-SS is recommended for sample gases with a temperature of up to 180 °C [356 °F]. Examples are measurements of flue gas of heavy oil and hard coal combustion plants.

The filter separates aerosols (finest liquid particles) which have still passed the sample gas cooler. After sample conditioning, the CLF is best positioned directly in front of the flow meter of the analyzer.

With regard to the CLF-T filter, the condition of the filter is immediately visible from the outside through the glass filter body without opening the filter assembly. The GL 25 or G 3/8"-connection allows an automatic emptying of the liquid by means of an optional external peristaltic pump SR25.2.W or automatic condensate flow trap AD-SS.

No tools are required for filter element replacement. The optimum positioning of the O-ring always ensures a reliable sealing of the filter body to the filter head.

Filter inlet and outlet can be rotated 180° on the wall-mounting so that flexible adaptation to local conditions is possible during installation.

The filter is available in PTFE/glass or stainless steel 316Ti.

### Description

The filter element of the M&C liquid particle filter CLF® has a two-layer construction and the flow direction is from the inside to the outside. The inner, very fine layer binds the fine liquid particles suspended in the gas and passes them on to the outer, coarser layer with the gas flow. On their way through the filter element, the very fine liquid particles accumulate to form droplets. The vertical flow direction, together with gravity, supports the dripping of the liquid into the filter glass.

The filter element retains its efficiency even when completely saturated with liquid. Without being contaminated by solid particles, its service life is almost unlimited. The pressed microfibers are joined with PVDF binder to prevent the influence on sample gas.

**Handle with care! Danger of acid burns!**

# Dimensions



CLF-T

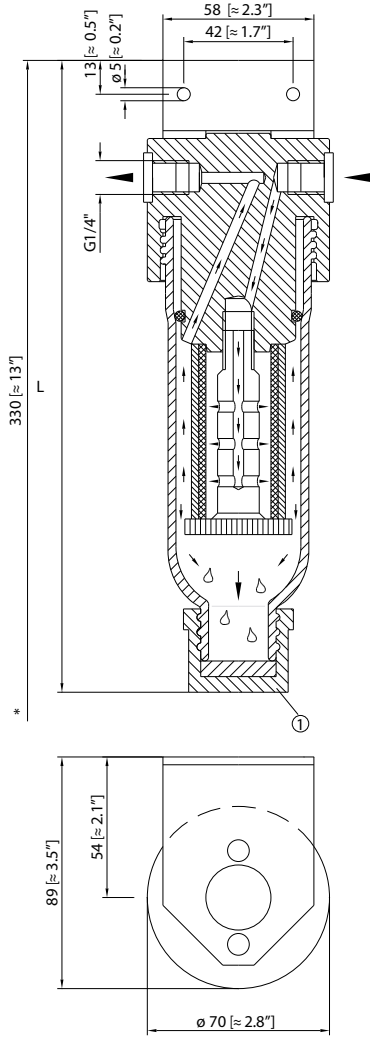

CLF-SS

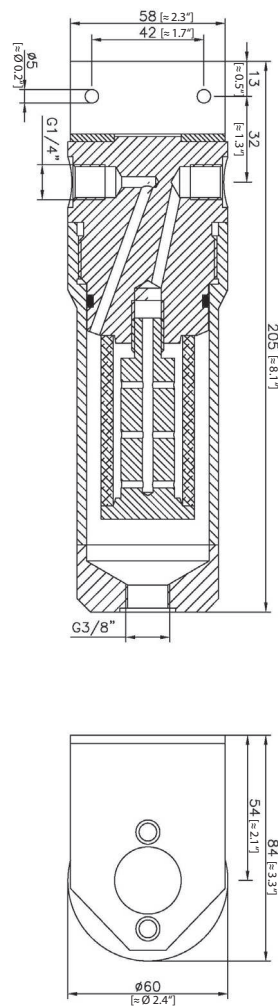

Version:	CLF-T	CLF-SS
Measure L:	240 [≈ 9.5"]	210 [≈ 8.3"]
Drain:	① GL25	G3/8"i

\*Dimensions required for dismounting 330 [≈ 13"]

Dimensions in mm [Inches]

## Technical Data

Liquid particle filter	CLF-T	CLF-SS
Part No.	03F2100	03F2300
Material of sample-contacting parts	PTFE, glass, FKM	Stainless steel 316Ti, FKM
Gas pressure ( $\Delta P$ max. 1 bar)	0.2 to 2 bar abs.	0.2 to 26 bar abs.
Gas flow	Max. 300 NI/h	
Differential pressure for a new filter element, with air, 20 °C [68 °F]	1 2.5 4.5 mbar 100 200 300 NI/h	
Sample gas temperature	Max. 100 °C [212 °F]	Max. 180 °C [356 °F]
Ambient temperature	0 to +100 °C [32 to 212 °F]	0 to +180 °C [32 to 356 °F]
Storage temperature	-30 to +120 °C [-22 to 248 °F]	-30 to +180 °C [-22 to 356 °F]
Filter element	2-layer CLF-4	
Retention rate	99.99 % for particles > 0.1 µm	
Filter stagnant space	135 cm <sup>3</sup>	
Volume capacity for liquid	50 ml	
Sample gas connection	G 1/4" i DIN ISO 228/1	
Drain connection	GL 25 cap	G 3/8" plug
Type of mounting	Wall-mounting	
Weight	Approx. 0.8 kg [≈ 1.8 lbs]	Approx. 2.2 kg [≈ 4.9 lbs]

Please note: NI/h and NI/min refer to the German standard DIN 1343 and are based on these standard conditions: 0 °C [32 °F], 1013 mbar.



# Universal Bypass Filter Series FP® for Liquid Filtration

Versions FP-70P200-D, FP-70P190-D, FP-200P190-D

## Special Features

- **Liquid filtration in a settling area or with self-cleaning effect through bypass flow possible**
- **Coarse mesh filter element made of PP**
- **Filter head made of PVDF**
- **Filter element condition is visible from outside through the glass filter body**
- **With wall-mounting bracket**

## Application

The M&C universal bypass filters are mainly used in liquid analysis for the filtration of small sample quantities from a liquid flow. Two different filtration methods are available:

In order to obtain the desired self-cleaning effect, the bypass filters FP-70(200)P190-D should be operated with a minimum bypass flow of 300 NI/h.

### 1. Filter Type FP-70P200-D:

Filtration of a liquid flow in a settling area.

### 2. Filter Type FP-70(200)P190-D:

Filtration of a liquid flow with self-cleaning effect through a bypass flow with fast flow rate via the active filter element surface.

## Description

The basic construction of the bypass filter corresponds to the line of universal filters which are used for gas filtration. The coarse mesh filter element is supplied with a pore grade of 70 or 200 µm and is manufactured out of PP including the supporting pillar. The filter element is screwed into the filter head with the filter element holder.

Through the glass filter body, the condition of the filter element is visible from the outside at any time without dismantling the filter. For changing the filter elements, no tools are necessary.

The optimum positioning of the o-ring guarantees a safe sealing of the filter body to the filter head. The sample outlet can be rotated 180° at the wall-mounting bracket so that during installation, flexible handling is possible according to different local conditions.

The sample connections are located in the filter head and in the lower section of the filter glass. Corresponding tube connectors and GL 25 adaptors in DN 4/6, 6/8, 8/10 or 10/12 are optionally available.

**Filter FP-70P200-D**  
Filtration in a settling area

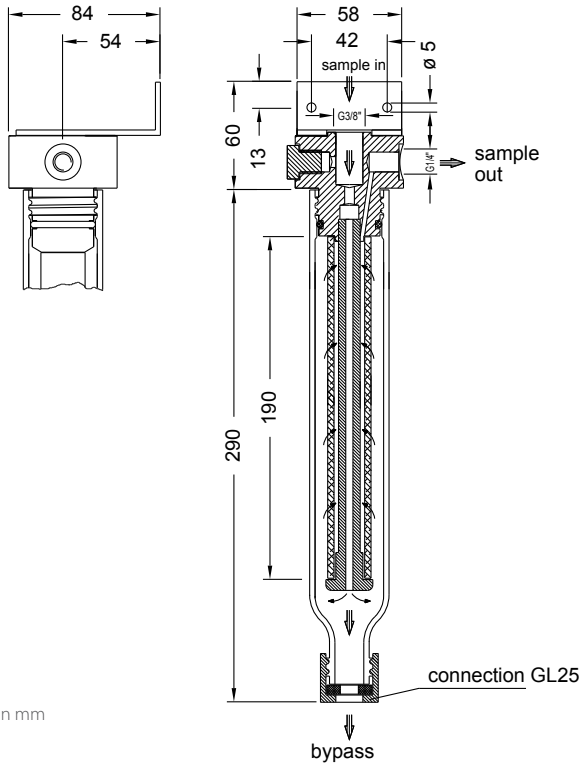

Dimensions in mm

**Filter FP-70-P190-D/FP200P190-D**  
Filtration with self-cleaning effect through bypass flow

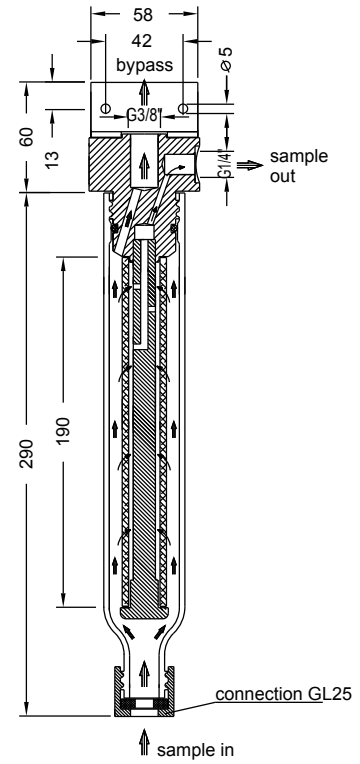

**Flow rate in relation to inlet pressure**

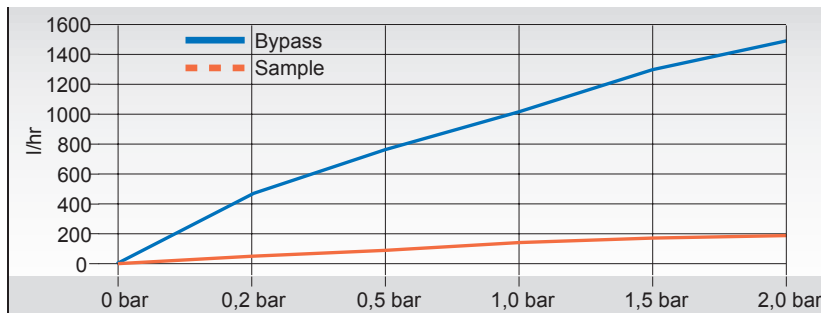

**Technical Data**

Liquid bypass filter series FP®	FP-70P200-D	FP-70P190-D	FP-200P190-D
Part No.	02F1400	02F1440	02F1450
Filtration in a settling area	Yes	No	
Filtration with self-cleaning-effect	No	Yes	
Filter element porosity	70 µm		200 µm
Bypass connections	G 3/8" female DIN ISO 228/1* and GL25-12		GL25-12 and G3/8" female DIN ISO 228/1*
Sample connection	G 1/4" female DIN ISO 228/1*		
Max. pressure at 20 °C [68 °F]	Max. 2 bar abs. or max. 5 bar abs. with GL connecting adapter		
Bypass flow max.	1500 NI/h		
Sample max.	180 NI/h		
Sample temperature max.	80 °C [176 °F]		
Ambient temperature max.	80 °C [176 °F]		
Filter surface	180 cm²		
Volume	100 ml		
Weight	Approx. 650 g [≈ 1.4 lbs]		
Method of mounting	Wall-mounting		
Material of sample-contacting parts	PVDF, PP, glass, FKM		

\* The dimensions and designation of the screw-in threads correspond to the respective applicable standard. The tolerances of the thread standards are matched to metal threads and cannot be applied to plastic threads.  
Please note: NI/h and NI/min refer to the German standard DIN 1343 and are based on these standard conditions: 0 °C [32 °F], 1013 mbar.



FP-AP

## Universal Adsorption Filter Series FP®

Versions FP-240-D/F, FP-120-D/F and FP-AP, FT-AP, FS-AP for adsorption material

### Special Features

- Can be filled with a variety of adsorption materials
- Easy change of filling materials
- Condition of filling material visible from outside
- Various materials available
- Wall-mounting

### Application

The M&C Universal Filters FP-240-D/F, FP-120-D/F and FP-AP, FT-AP, FS-AP are used in analytical technology for the adsorption of interfering components.

### Description

The M&C filter assembly FP...-D/F for larger filling quantities consists of the standard filter head FP and a special, approx. 200 mm long glass body F-240G-D/F in the case of version FP-240-D/F, or an approx. 100 mm long glass body F-120G-D/F in the case of version FP-120-D/F. The glass bodies are equipped with a pre-filter in the lower section, whereupon the filling can be entered. The flow direction to these fittings is from below via the GL 25-6 glass connection upwards to the filter head.

The M&C filter assembly F...-AP for small filling quantities consists of the standard filter head FP, FT or FS, in which an empty cartridge F...-AP for adsorbents is screwed in. The sample gas is directed downwards in the filter housing and flows through the cartridge from the bottom to the top, thereby ensuring a long contact with the adsorbent over the entire length of the cartridge. The design of this M&C filter assembly guarantees that only liquid-free gas flows through the cartridge when condensate droplets occur.

The condition of the filling material can be assessed from the outside without having to open the filter housing. No tools are required to change the filling, whereby the optimum positioning of the O-ring always ensures a secure sealing between the filter body and the filter head. Filter inlet and outlet can be rotated 180° on the wall bracket so that flexible adaptation to local conditions is possible during installation.

Downstream of the adsorption filter, an ultra-fine particle filter should still be used.



Universal Filter FP-240(120)-D/F

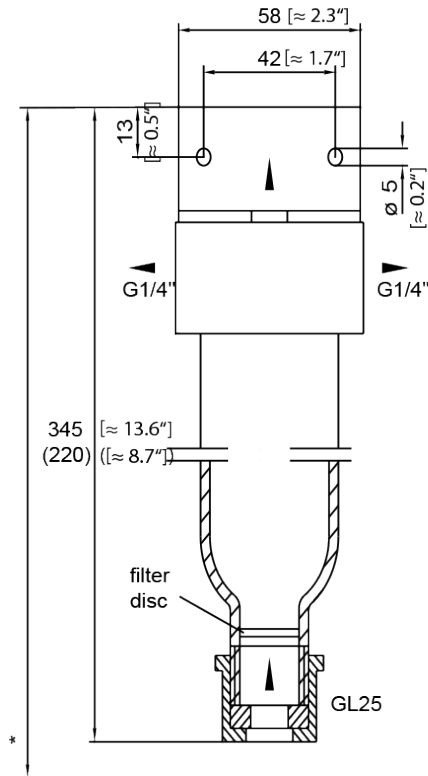

\* constructional size 380 mm at FP-240-D/F  
(255) mm at FP-120-D/F

Universal Filter F...-AP

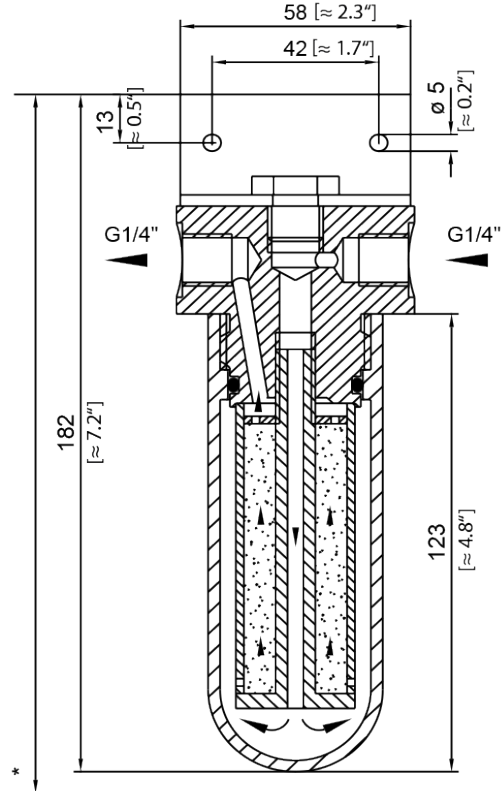

\* constructional size 290 [≈ 11.4"]

Dimensions in mm [Inches]

Technical Data

Universal filter	FP-240-D/F	FP-120-D/F	FP-AP	FT-AP	FS-AP
Part number	03F5600	03F5650	03F5000	03F5200	03F5100
Material of medium-contacting parts: filter head, cartridge, o-ring, glass body	PVDF, FKM, glass		PVDF, PVC, FKM, glass	PTFE, PVDF, FEP, glass	1.4571, PVC, FKM, glass
Stagnant space	190 cm <sup>3</sup>	75 cm <sup>3</sup>	65 cm <sup>3</sup>		
Operating temperature	-20 to +80 °C [-4 to 176 °F]		0 to +55 °C [32 to 131 °F]	-20 to +80 °C [-4 to 176 °F]	0 to +55 °C [32 to 131 °F]
Storage temperature	-30 to +110 °C [-22 to 230 °F]		-15 to +65 °C [5 to 149 °F]	-30 to +110 °C [-22 to 230 °F]	-15 to +65 °C [5 to 149 °F]
Operating pressure, at 20 °C [68 °F]	Max. 2 bar abs.		Max. 5 bar abs.		
Operating pressure with GL adapter	Max. 5 bar abs., at 20 °C [68 °F]				
Method of mounting	Wall-mounting, position of mounting: vertical				
Adsorption material	Standard scope of supply without material				
Connection	GL 25 - 6, G1/4" female*		G 1/4" female*		
Weight	0.5 kg [≈ 1.1 lbs]	0.3 kg [≈ 0.7 lbs]			0.5 kg [≈ 1.1 lbs]

\* The dimensions and designation of the screw-in threads correspond to the respective applicable standard. The tolerances of the thread standards are matched to metal threads and cannot be applied to plastic threads.

Selection of adsorption material

Adsorption material	Removes the interfering components	Cross-sensitive against	Package size	Part No.
Activated carbon	Oil and solvent vapours	SO <sub>2</sub> , CO <sub>2</sub> , CL <sub>2</sub> , NH <sub>3</sub>	2 x 500 g, granulated	90F5100
Stuttgarter Masse	Aerosols	HF	750 g, grain size 1.6 to 3 mm	90F5115
Stuttgarter Masse	Aerosols	HF	750 g, grain size 4 to 10 mm	90F5116
Silica gel	Water vapor	SO <sub>2</sub> , NH <sub>3</sub> , HCL, CO <sub>2</sub> , C <sub>n</sub> H <sub>m</sub>	1 kg, dry beads	90F5110
Calcium/sodium hydroxide	CO <sub>2</sub>	SO <sub>2</sub> , CL <sub>2</sub> , H <sub>2</sub> O	1 l	90F5130
Purafil Select	SO <sub>2</sub> , SO <sub>3</sub> , CS <sub>2</sub> , H <sub>2</sub> S	C <sub>2</sub> H <sub>2</sub> , C <sub>2</sub> H <sub>4</sub> , CH <sub>4</sub> O	750 g, granulated	90F5105



FPF-0,1GF

## Front-Panel Mounting Fine Filter Series FP®

Versions FPF-0,1GF, FPF-3SS and FPF-2-0,3GF

### Special Features

- Flat design
- Low internal dead volume
- Simple construction
- Easy assembly
- Straightforward change of filter element
- Universal applicability

### Application

The M&C front-panel fine filters with deep-acting filter element reliably separate the solid contaminations occurring in analytical technology during gas filtration, in particular ultra-fine particles. The FPF front-panel filters are equipped with a glass fiber ultra-fine filter element (0.1  $\mu\text{m}$ ) in the FPF-0.1GF version and with a stainless steel filter element (3  $\mu\text{m}$ ) in the FPF-3SS version. The FPF-2 installation filter is equipped with a round glass fiber filter element (0.3  $\mu\text{m}$ ). The large filter surface of the cylindrical filter element (versions FPF-0.1GF and FPF-3SS) ensures reliable ultra-fine filtration and long service life with low pressure loss.

The 19" front-panel mounting technology requires flat devices, for which the FPF-0,1GF, FPF-3SS and FPF-2-0,3GF front-panel filters were primarily developed.

### Description

Special features of the M&C front-panel filters FPF and FPF-2 are flat design, low internal dead volume, simple construction and assembly as well as universal usability.

The filter glass allows the condition of the filter to be seen immediately from the outside without opening the filter assembly. No tools are required to change the filter element, whereby the optimum positioning of the O-ring always ensures a reliable sealing between the filter glass and the filter body.

The gas connections are located at the rear of the filter body. The sample gas inlet can be rotated 180° at the front ring attachment so that flexible adaptation to local conditions is possible during installation.

The FPF-2-0.3GF has an integrated liquid alarm sensor.

Corresponding tube connections are optionally available.

Front-panel mounting fine filter FPF-0,1GF

ore-hole in frontpanel  $\varnothing 50$  [ $\approx 2$ "]

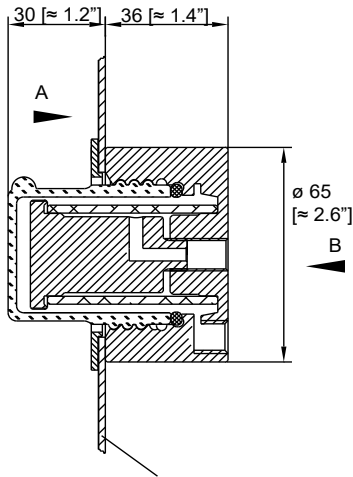

Bore-hole in frontpanel  $\varnothing 50$  [ $\approx 2$ "]

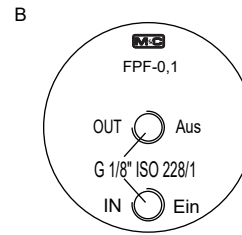
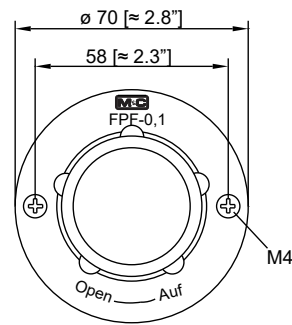

Differential pressure in mbar depending on flow rate in NI/h air and with a new filter element.

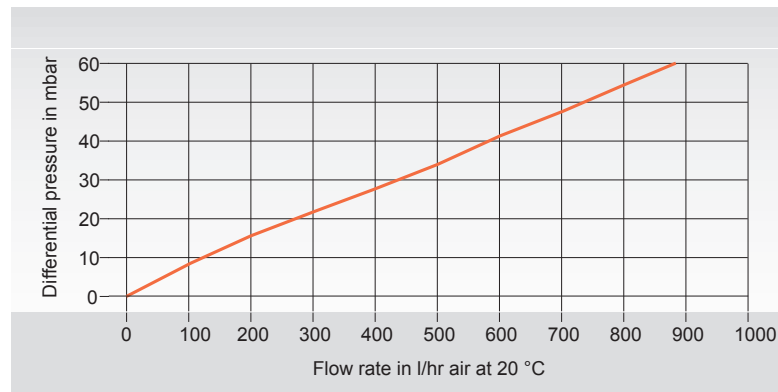

Front-panel mounting fine filter FPF-2-0,3GF

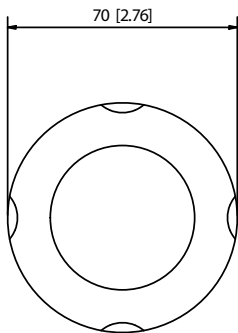

Dimensions in mm [Inches]

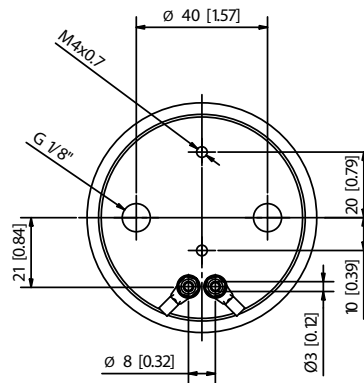
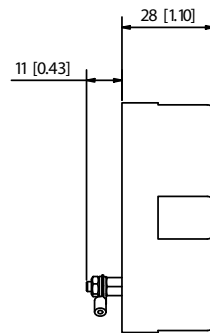

Technical Data

Front-Panel Mounting Fine Filter Series FP*	Version FPF-0,1	Version FPF-3SS	Version FPF-2-0,3GF
Part No.	04F1000	04F1005	04F2000
Filter element	Glass fiber 0.1 $\mu\text{m}$ (others on request)	Stainless steel 3 $\mu\text{m}$	Round filter element, glass fiber 0.1 $\mu\text{m}$
Connections	G 1/8" female DIN ISO 228/1*		
Pressure	Max. 4 bar g		Max. 1.4 bar
Sample temperature	Max. 80 °C [176 °F]		Max. 45 °C [113 °F]
Ambient temperature	Max. 80 °C [176 °F]		Max. 45 °C [113 °F]
Filter surface	50 cm <sup>2</sup>		23 cm <sup>2</sup>
Internal dead volume	30 ml		15 ml
Weight	280 g [ $\approx$ 0.6 lb]	330 g [0.73 lb]	130 g
Type of mounting	Front-panel mounting		
Material of sample-contacting parts	PTFE, PVDF, glass, FKM, glass fiber	PTFE, PVDF, glass, FKM, stainless steel	PVC, acrylic glass, Viton®

\* The thread lengths of the screw-in threads correspond to the respective applicable standard. The tolerances of the thread standards are matched to metal threads and cannot be applied to plastic threads.  
 Viton® is a registered trademark for fluoroelastomers by DuPont Performance Elastomers, USA.



FPF+

# Front-Panel Mounting Fine Filter Series FPF®

Version FPF+

## Special Features

- **Corrosion-resistant materials**
- **Large filter elements**
- **Great variety of filter element materials with different porosities available**
- **With connection for optional liquid alarm sensor LA3**
- **Medium and ambient temperature: max. +80 °C**
- **Low internal dead volume**
- **Straightforward filter element change without tools**
- **Universal usability**

## Application

The solid contaminations occurring in analytical technology during gas filtration, in particular ultra-fine particles, are reliably separated by the M&C front-panel mounting filter. The large filter surface of the cylindrical, 75 mm long filter element guarantees reliable ultra-fine filtration and a long service life with low pressure loss.

The optionally integrated liquid alarm sensor LA3 is used in gas conditioning systems for monitoring gas cooling and condensate drains to protect downstream analysis equipment. This simple monitoring device reliably signals condensate ingress in the event of a defect in cooling equipment or condensate drains and prevents expensive downtime and high repair costs for analytical equipment.

In the event of alarm, the power for the sample gas pump or a solenoid valve is to be switched off in the gas sample conditioning system.

Corresponding tube connectors can be optionally supplied (see data sheet "Flexible and rigid tube fittings, plugs and connectors with barbed fitting").

The optionally integrated liquid sensor LA3 works according to the principle of electrical conductivity from a conductance value of 50  $\mu\text{S}/\text{cm}$ . To prevent electrolytic effects on the sensor surface, the sensor is operated with alternating current.

The liquid sensor is located in the sample gas inlet in such a way that any liquid droplets in the sample gas flow are directly attracted to the sensor surface due to gravity and even the smallest liquid droplets trigger a safe and fast alarm.

The required electronic controller LA-1 is available in various versions and is described in the separate data sheet "Electronic Controllers Series LA®".

## Description

Special features of the M&C front-panel mounting filter FPF+ are the large filter surface, a great variety of different filter element materials and porosities, the integrable liquid alarm sensor LA3, low internal dead volume, simple construction and assembly as well as universal applicability.

The condition of the filter is immediately visible from the outside through the filter glass without opening the filter fitting. No tools are required for changing the filter element, whereby the optimum positioning of the O-ring always ensures a reliable sealing between the filter glass and the filter body.

The gas connections are located at the rear of the filter body. If no liquid sensor is used, the sample gas inlet at the front ring attachment can be rotated in 90° steps so that flexible adaptation to local conditions is possible during installation.

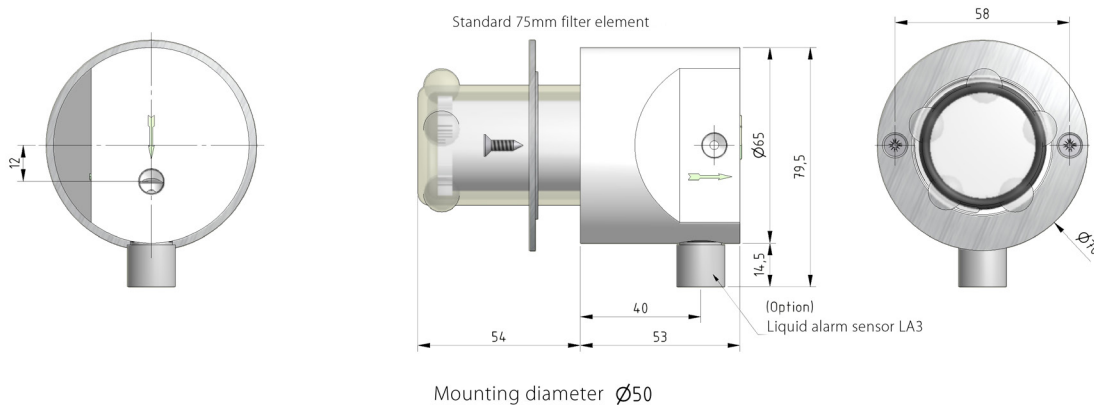

Mounting diameter Ø50

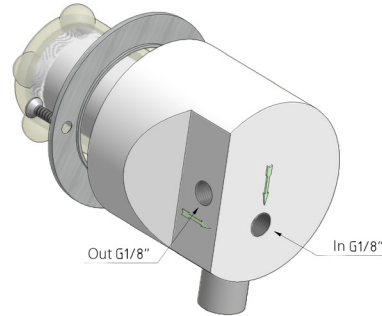

Dimensions in mm

## Technical Data

Front-Panel Mounting Filter Series FP*	Version PPF+
Part No.	04F2100
Filter element	None, see options
Liquid alarm sensor	None, see options
Sample gas connections	G 1/8" female DIN ISO 228/1
Pressure	Max. 4 bar g
Sample temperature	Max. 80 °C [176 °F]
Ambient temperature	Max. 80 °C [176 °F]
Filter surface	70 cm <sup>2</sup>
Internal dead volume	50 ml
Weight	330 g [≈ 0.7 lb] (without filter element, with liquid alarm sensor LA3)
Type of mounting	Front-panel mounting
Material of sample contacting parts	PTFE, glass, FKM

\* The dimensions and designation of the screw-in threads correspond to the respective applicable standard. The tolerances of the thread standards are matched to metal threads and cannot be applied to plastic threads.  
Appropriate fittings, see data sheet "Flexible and rigid tube fittings, plugs and connectors with barbed fitting"

## Options

Part No.	Description
03E1300	Liquid alarm sensor type LA3**, for conductive media, for mounting in PPF+, material: SS 316Ti, PTFE, FKM
90F0002	Filter element type F-2T, length: 75 mm, material: PTFE, porosity: 2 µm
90F0004	Filter element type F-20T, length: 75 mm, material: PTFE, porosity: 20 µm
90F0003	Filter element type F-50T, length: 75 mm, material: PTFE, porosity: 50 µm
90F0005	Filter element type F-3G, length: 75 mm, material: glass, porosity: 3 µm
90F0011	Filter element type F-2GF, length: 75 mm, material: glass fiber, porosity: 2 µm. VE = 25 pcs. (for mounting 2 adapter rings Part No. 93S0050 required)
90F0016	Filter element type F-0,1GF, length: 64 mm, material: glass fiber, porosity: 0.1 µm (for mounting 2 adapter rings Part No. 93S0050 required)
90F0550	Filter element type F-0,05SiC, length: 75 mm, material: ceramic, porosity: 0.05 µm
90F0006	Filter element type F-2K, length: 75 mm, material: ceramic, porosity: 2 µm
90F0007	Filter element type F-20K, length: 75 mm, material: ceramic, porosity: 20 µm
90F0008	Filter element type F-3SS, length: 75 mm, material: SS 316L, porosity: 3 µm
90F0010	Filter element type F-20SS, length: 75 mm, material: SS 316L, porosity: 20 µm
90F0115	Spun glass cartridge FW-1 for universal filter, without filling, material: SS 316Ti
90F0117	Spun glass cartridge FW-2 for universal filter, without filling, material: PVDF
93S2083	Spec. spun glass, high temperature-resistant for spun-glass cartridge FW, content: 1000 g
93S0050	Adapter ring for filter element F-0,1GF and F-2GF, material: PTFE (1 pc.)

\*\* Appropriate electronic controller see data sheet "Electronic Controllers Series LA®"



FT®, FSS®, FP®, FS®

## Universal Filter Series FP®, FT®

Versions FP, FT, FS, FSS

### Special Features

- **Universal in use**
- **Modular design**
- **Large variety of materials**
- **Deep-acting filter element**
- **Reliable separation of solids**
- **Wall-mounting bracket**
- **Easy maintenance**

### Application

M&C universal filters reliably separate solids, in particular extremely fine particles, occurring in analysis techniques in gas filtration, using very fine, deep-acting filter elements.

Thanks to their universal design, the filters can also be used as separators (without a filter element), liquid filters or, with adsorption cartridges, as adsorption filters.

For ambient or medium temperatures up to 180 °C [356 °F], a stainless steel version FSS or FT-H version can be offered.

### Description

The modular design of the filters and the compatibility of the fitting components filter head, filter body and filter element enable optimum adaptation to process conditions.

Elements of different materials and porosities are available and their degree of contamination and condition can be assessed from the outside without having to open the filter housings (not with FSS).

No tools are required for element replacement, and the optimum positioning of the O-ring always ensures a safe sealing between the filter body and the filter head.

The filters are designed in such a way that only liquid-free gas flows through the filter elements when condensation droplets accumulate.

The versions FP-D, FT-D, FS-D and FSS-D can also be connected to a condensate trap or a liquid alarm sensor. Filter inlet and outlet can be rotated 180° on the mounting bracket so that flexible adaptation to local conditions is possible during installation.

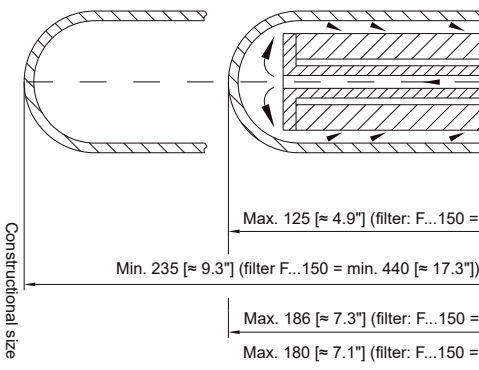

**FP-D, FT-D, FS-D with LA1**

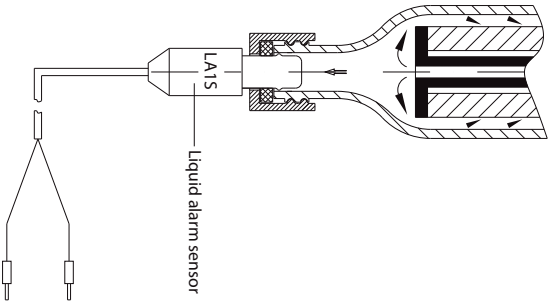
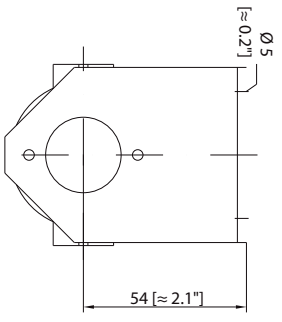

Dimensions in mm [inches]

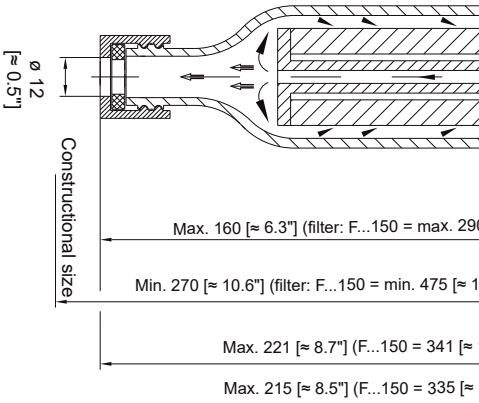

**FSS-D**

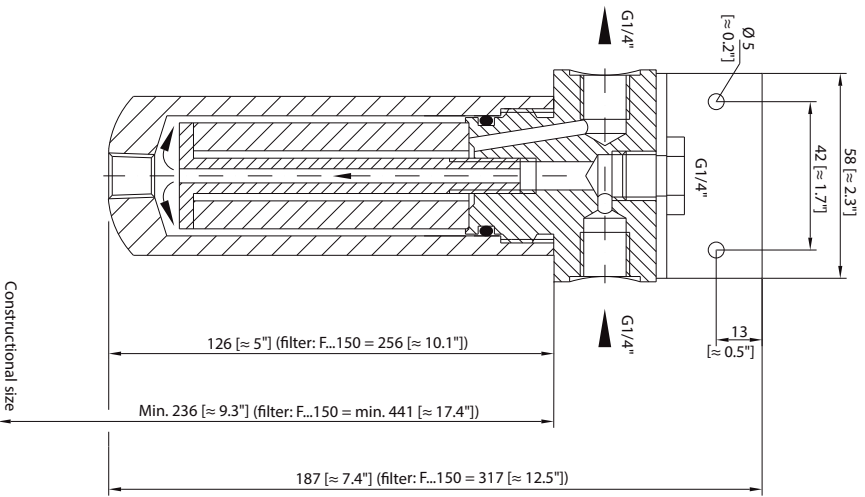

# Flow rate in NI/h air and differential pressure in mbar with clean filter elements

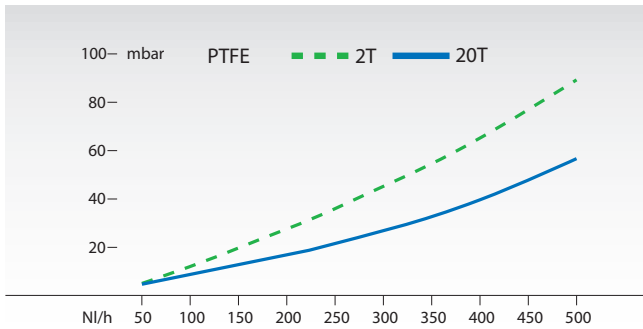

Flow rate	50	100	150	200	250	300	350	400	450	500	NI/h
Differential pressure 2T	7	14	22	30	39	48	57	66	76	88	mbar
Differential pressure 20T	4	8	12	18	23	29	35	41	48	55	mbar

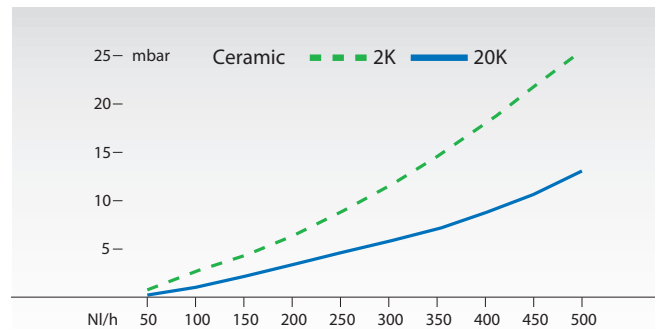

Flow rate	50	100	150	200	250	300	350	400	450	500	NI/h
Differential pressure 2K	1.5	3	5	7	9.5	13	15	19	22	26	mbar
Differential pressure 20K	0.5	1.5	2.5	3.5	4.5	6	7.5	9	11	13	mbar

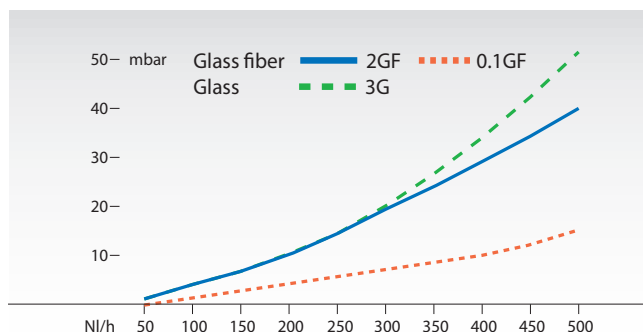

Flow rate	50	100	150	200	250	300	350	400	450	500	NI/h
Differential pressure 3G	1	3	6	11	14.5	21	27	33	43	52	mbar
Differential pressure 2GF	2	4.5	7.5	12	15	19	24	29	34	40	mbar
Differential pressure 0.1GF	0.5	2	3	4	5	6	7	10	11	15	mbar

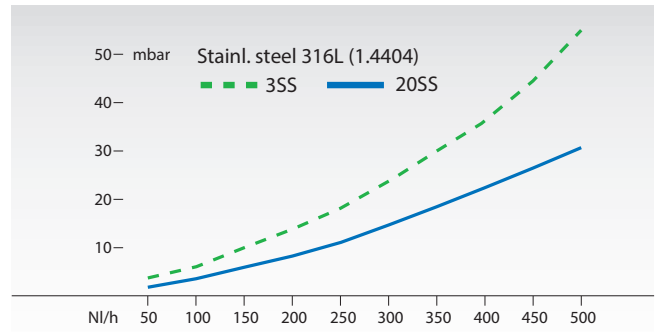

Flow rate	50	100	150	200	250	300	350	400	450	500	NI/h
Differential pressure 3SS	4	6	10	14	18	25	30	36	43	54	mbar
Differential pressure 20SS	2	4	6	8.5	10.5	14	19	22	26	31	mbar

## Technical Data

	FP, FT, FT-H, FS	FP-D, FT-D, FS-D	FSS, FSS-D
Length of filter element	75 mm, Option: F...150 = 150 mm		
Sample connections: gas inlet/-outlet	3 x G 1/4i (1 x closed) DIN ISO 228/1* FS, FSS, FSS-D: optional NPT		
Condensate connection		GL 25 - ø 12 mm	FSS-D = G 1/4 i, optional NPT
Pressure at 20 °C [68 °F]	Max. 5 bar abs.	Max. 2 bar abs.	250 bar**, F...150 = 200 bar**
Pressure with GL connection adapter		5 bar abs.	
Internal dead volume	65 cm <sup>3</sup> , F...150 = 180 cm <sup>3</sup>	75 cm <sup>3</sup> , F...150 = 190 cm <sup>3</sup>	40 cm <sup>3</sup> , F...150 = 70 cm <sup>3</sup>
Filter surface	70 cm <sup>2</sup> , F...150 = 140 cm <sup>2</sup>		
Materials: Filter head	PVDF, PTFE, PTFE-ko, stainless steel 316Ti		Stainless steel 316Ti
Filter body	Glass		Stainless steel 316Ti
Filter element	PTFE, glass, glass fiber, ceramic, stainless steel, wire cloth stainl. steel		
Seals: O-ring	FP/-D, FT-H, FS/-D = FKM, FT/-D = FEP		FKM
...-D-connection			PTFE/silicone
Temperature of ambient or sample max.	80 °C [176 °F] PVDF, 100 °C [212 °F] PTFE, 180 °C [356 °F] PTFE-ko, stainless steel, glass (fiber), ceramics		
Method of mounting	Wall-mounting		
Weight approx.	0.4-1.0 / F...150 = 0.5 to 1.2 kg [≈ 1.1 to 2.7 lbs]		1.5/F...150 = 2.0 kg [≈ 4.4 lbs]

\* The thread lengths of the screw-in threads correspond to the respective applicable standard. The tolerances of the thread standards are matched to metal threads and cannot be applied to plastic threads.

\*\* At 180 °C [356 °F], 50 bar

Please note: NI/h and NI/min refer to the German standard DIN 1343 and are based on these standard conditions: 0 °C [32 °F], 1013 mbar.



Filter Elements	Filter Head	Filter Body	Filter Type	Part No.			
				F...-...	F...-...-D		
PTFE F-2T, 2 µm F-20T, 20 µm	universal in use	PVDF	Glass	FP-2T	/-D	01F1200	02F1000
		PVDF	Glass	FP-20T	/-D	01F1400	02F1200
		PTFE	Glass	FT-2T	/-D	01F2200	02F2000
		PTFE	Glass	FT-20T	/-D	01F2400	02F2200
		Stainl. steel 316Ti	Glass	FS-2T	/-D	01F4000	02F2650
		Stainl. steel 316Ti	Glass	FS-20T	/-D	01F4100	02F2660
		Stainl. steel 316Ti	Glass	FS-50T	/-D	01F1410	
		Stainl. steel 316Ti	Stainl. steel 316Ti	FSS-2T	/-D	01F7100	02F2665
		Stainl. steel 316Ti	Stainl. steel 316Ti	FSS-20T	/-D	01F7250	02F2670
		Glass (G) F-3G, 3 µm	universal in use	PVDF	Glass	FP-3G	/-D
PTFE	Glass			FT-3G	/-D	01F2850	02F2050
Stainl. steel 316Ti	Glass			FS-3G	/-D	01F6500	02F2692
Stainl. steel 316Ti	Stainl. steel 316Ti			FSS-3G	/-D	01F7300	02F2675
Glass fiber (GF) F-2GF, 2 µm	for high dust levels	PVDF	Glass	FP-2GF	/-D	01F1900	02F1490
		PTFE	Glass	FT-2GF	/-D	01F2900	02F2100
		Stainl. steel 316Ti	Glass	FS-2GF	/-D	01F6600	02F2715
		Stainl. steel 316Ti	Stainl. steel 316Ti	FSS-2GF	/-D	01F7200	02F2677
Glass fiber (GF) F-0, 1GF, 0,1 µm	for ultra fine filtration	PVDF	Glass	FP-0, 1GF	/-D	01F1500	02F1500
		PTFE	Glass	FT-0, 1GF	/-D	01F2950	02F2400
		Stainl. steel 316Ti	Glass	FS-0, 1GF	/-D	01F6700	02F2710
		Stainl. steel 316Ti	Stainl. steel 316Ti	FSS-0, 1GF	/-D	01F7150	02F2685
Ceramic F-2K, 2 µm F-20K, 20 µm	large separation at low differential pressure	PVDF	Glass	FP-2K	/-D	01F1000	02F1300
		PVDF	Glass	FP-20K	/-D	01F1100	02F1310
		PTFE	Glass	FT-2K	/-D	01F2000	02F2300
		PTFE	Glass	FT-20K	/-D	01F2100	02F2310
		Stainl. steel 316Ti	Glass	FS-2K	/-D	01F5000	02F2550
		Stainl. steel 316Ti	Glass	FS-20K	/-D	01F5100	02F2560
		Stainl. steel 316Ti	Stainl. steel 316Ti	FSS-2K	/-D	01F7050	02F2690
		Stainl. steel 316Ti	Stainl. steel 316Ti	FSS-20K	/-D	01F7060	02F2695
Stainless steel 316L F-3SS, 3 µm F-20SS, 20 µm	for high pressure humid and trace gas measurement	PVDF	Glass	FP-3SS	/-D	01F1600	02F1550
		PVDF	Glass	FP-20SS	/-D	01F1800	02F1560
		PTFE	Glass	FT-3SS	/-D	01F2600	02F2600
		PTFE	Glass	FT-20SS	/-D	01F2800	02F2500
		Stainl. steel 316Ti	Glass	FS-3SS	/-D	01F6000	02F2667
		Stainl. steel 316Ti	Glass	FS-20SS	/-D	01F6010	02F2680
		Stainl. steel 316Ti	Stainl. steel 316Ti	FSS-3SS	/-D	01F7000	02F2700
		Stainl. steel 316Ti	Stainl. steel 316Ti	FSS-20SS	/-D	01F7010	02F2705
Wire cloth stainless steel 316L F-100SSG, 100 µm F-250SSG, 250 µm		Stainl. steel 316Ti	Stainl. steel 316Ti	FSS-100SSG		01F7015	
		Stainl. steel 316Ti	Stainl. steel 316Ti	FSS-250SSG		01F7020	

All filter units are also available with double-sized element F-3G 150, F-2K 150 and F-0,1GF 150, and types FS, FSS with NPT thread.

To avoid damage of gas analyzers due to faulty pre-installed gas drying systems, M&C recommends a liquid alarm sensor.

Liquid alarm sensors incl. electronic controllers, upon request see data sheets "Liquid Alarm Sensors Series LA" for Conductive Media, "Electronic controllers series LA" and "Liquid Alarm Sensor KS3/KS3 EX, KS3 EX PEEK, KS3 EX PEEK SS, KS3 EX SS".

For special applications see data sheets

**Filters:** "Front-Panel Mounting Fine Filter Series FP\*", "Electrically Heated Universal Filter Series FT\*", "Universal Bypass Filter Series FP" for Liquid Filtration, "Universal Adsorption Filter Series FP\*", "Liquid Particle Filter Series CLF\*", Versions CLF-T, CLF-SS", "Liquid Particle Filter Series CLF\*", Version CLF-5, CLF-5/W"

**Separators:** "Series FP\*, FT\* Universal Condensate Separators", "Separator with Automatic Condensate Float Trap, Versions ADS-P, ADS-T, ADS-So", "Separator with Automatic Condensate Float Trap, Version ADS-SS"

**Wash bottles:** "Wash Bottle Series FP"

**Option**

**Acrylic glass cover PS and thread adaptor piece PS 1**

Acrylic glass protection cover PS for standard filter glass type F-120 G, part No. 90F0032, threaded counterpart PS 1 for mounting PS, part No. 90F0018

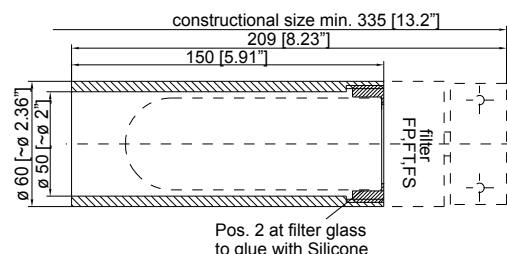

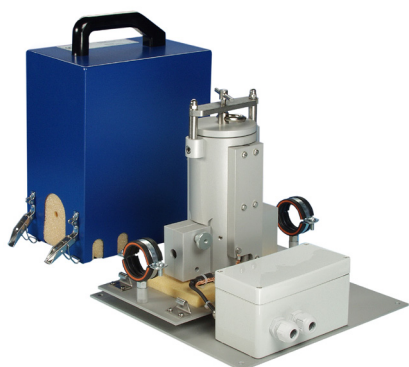

FSS-.../H350

# Electrically Heated Filter

## Type FSS-2K/H350, FSS-3SS/H350 and FSS-FW/H350

with integrated thermostat, max. 350 °C [662 °F]

### Special Features

- Electrically heated, max. 350 °C [662 °F]
- Large filter surface
- Consistent connection technique
- No cold bridges
- Integrated thermostat
- Status alarm
- Easy maintenance

### Application

The electrically heated M&C filter type FSS/H350 is used for the separation of solid contaminations in analytical technology up to an operating temperature of 350 °C [662 °F]. Filter elements with high filter porosity and great deep-acting effect are used for optimum filtration of ultrafine particles.

The overall concept guarantees reliable operation and easy maintenance. Filter cleaning or filter element replacement can be carried out without using tools, and the heated sample lines do not have to be dismantled for this purpose.

### Description

The electrically heated M&C filter FSS/H350 is mounted on a thermally insulated mounting plate. The stainless steel filter body with integrated filter element, optionally ceramic, stainless steel or glass fibre filter wool, is fully enclosed by a metallic heat-conducting jacket. Heating is provided by a high-performance heating element. The control temperature can be set from +50 °C to 350 °C [122 to 662 °F] at the integrated control thermostat with high temperature limiter at 30 °C above the setpoint and low temperature alarm contact at 30 °C below the setpoint.

To avoid cold bridges, the gas-tight welded connection fittings are also heated by means of two-part heat-conducting jaws. The filter has a thermally insulated cover. The electrical terminal box with integrated thermostat and two tube clamps are located outside the cover. These serve to fasten the electrically heated sample lines - see data sheets for electrically heated sample lines type 3/4/5-N/M/H, type 3/4M-S for permanent installation, type 3/4/5-N/M EX and type 3/4/5-5/30/50/80/100/120 (Ex).

Heated Filter Type FSS/H350

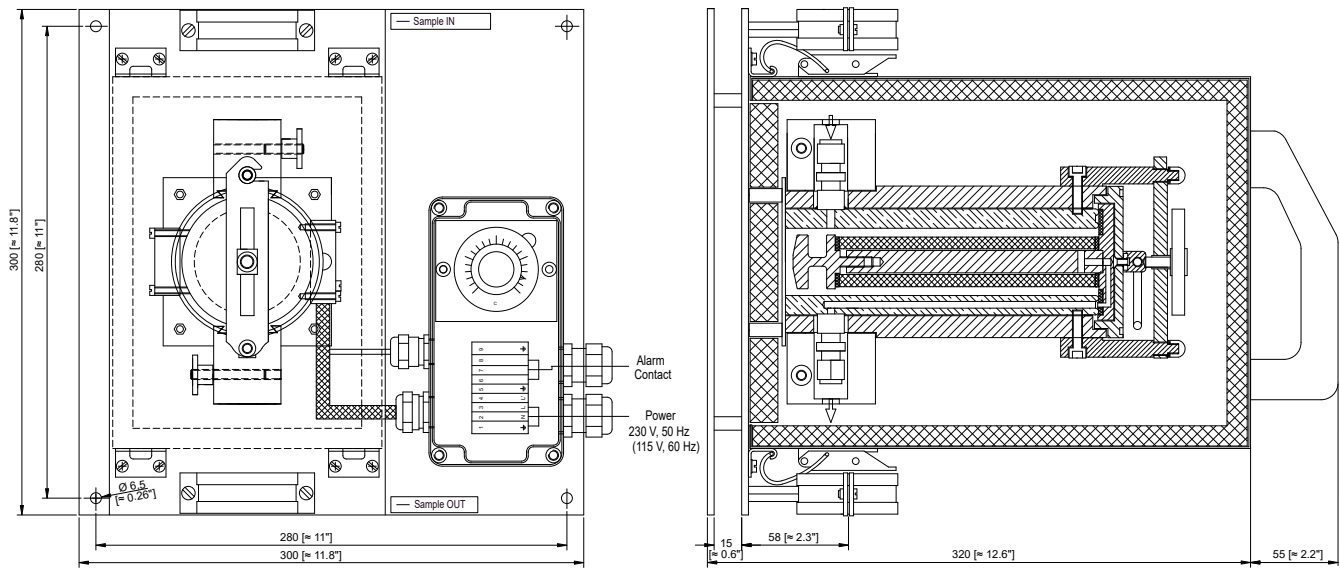

Dimensions in mm [Inches]

Technical Data

Heated filter type	FSS-2K/H350	FSS-3SS/H350	FSS-FW/H350
Part No.	01F3035(a)*	01F3030(a)*	01F3045(a)*
Filter element length 150 mm, material	Ceramic	Stainless steel SS316	Spun glass
Filter porosity	2 µm	3 µm	
Filter surface	140 cm <sup>2</sup>		
Operating pressure max.	5 bar g		
Ambient temperature/storage temperature	-20 °C to +60 °C [-4° F to 140 °F]		
Dead volume	130 cm <sup>3</sup>		
Gas connections	Swagelok tube connector ø 6 mm, optional ø 1/4"		
Temperature controller	Capillary tube thermostat integrated in electrical junction box, with high temperature limiter and low temperature alarm contact		
Operating temperature	Adjustable from +50 °C to 350 °C [122 °F to 662 °F], factory-set at 250 °C [482 °F]		
Temperature alarm contact	Alarm point at -30 °C below T <sub>SET</sub> change over contact, voltage-free, contact rating 250 V, 3 A ~0.25 A =		
Power supply	230 V 50 Hz, 800 VA or Part No. with (a)*: 115 V, 60 Hz		
Electrical connections	Terminals 4 mm <sup>2</sup> , 2 x cable glands PG13		
Method of mounting	Wall-mounting		
Protection classification/electrical standard	IP 54 EN 60529/EN 61010, EN 60519-1		
Dimensions (W x H x D)	250 x 300 x 300 mm [≈ 9.8" x 11.8" x 11.8"]		
Weight	11 kg [≈ 24.3 lbs]		
Material of sample-contacting parts	Filter chamber: stainless steel 316Ti/sealing: graphite		

\* (a) is an addition to the Part No. for 115 V versions.

Differential pressure in mbar with clean filter element

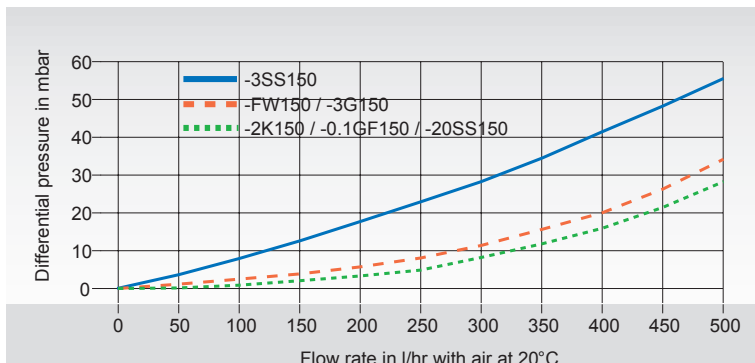

The differential pressure data of filter element FW150 are average values depending on the variable filling density.



FT...H2

# Electrically Heated Universal Filter Series FT®

Version FT-...-H2, heated at 180 °C [356 °F]

## Special Features

- Electrically heated, max. 180 °C [356 °F]
- Consistent connection technique
- No cold bridges
- Integrated thermostat
- Status alarm
- Easy maintenance

## Application

The electrically heated M&C universal filter is used for separating solid contaminations in analytical technology up to max. 180 °C [356 °F] operating temperature.

Filter elements with high filter porosity and great deep-acting effect are used for optimum filtration of ultra-fine particles.

## Description

The universal filter made of temperature-resistant PTFE with integrated filter element (porosity: 3 µm or 0.1 µm) is located in a two-part aluminium body.

Heating and temperature control are provided by a heating cartridge and an adjustable thermostat (Pt100 resistance thermometer on request) incl. high temperature limiter and low temperature alarm with 30 °C fixed to the temperature setpoint.

The switching element of the thermostat and the electrical connection terminals are arranged in a junction box. The operating temperature of the filter is indicated by a thermometer. For thermal insulation and for reasons of touch protection, the heated filter section is covered with an insulated cover.

In order to prevent cold spots at the connection fittings, these are also heated. Tube clamps on both sides are used to support the sample lines.

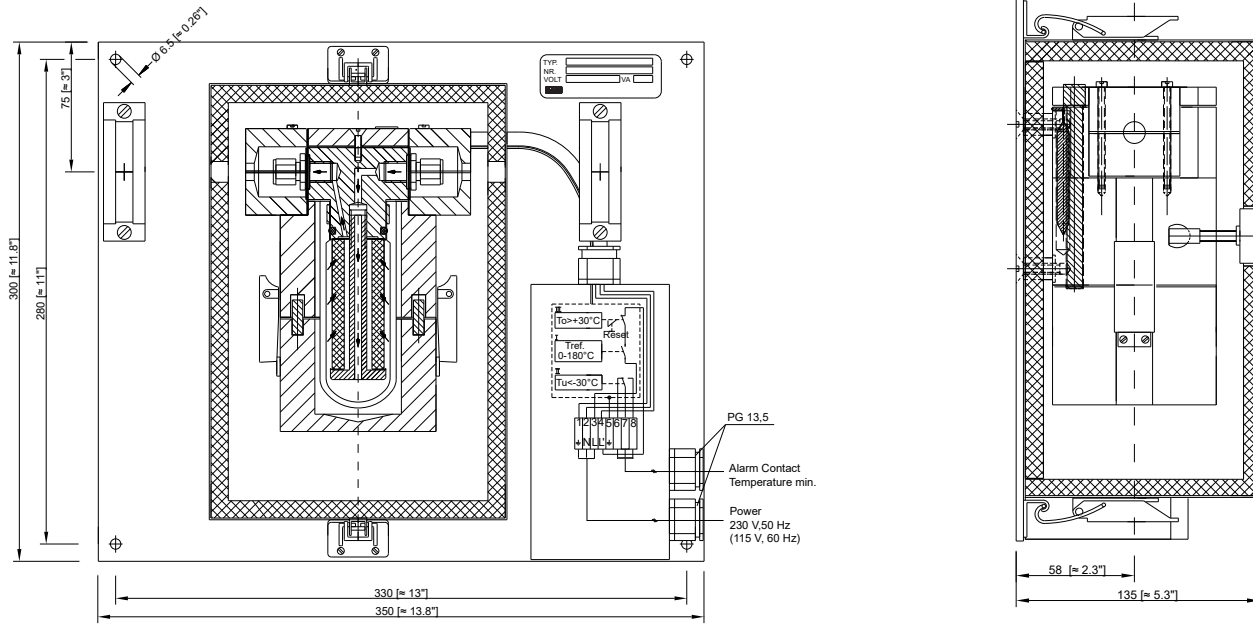

Dimensions in mm [Inches]

Technical Data

Filter series FT*	FT-3G-H2	FT-3SS-H2	FT-0,1GF-H2
Part No.	01F3006(a)*	01F3008(a)*	01F3007(a)*
Filter porosity/material of filter element	3 µm/glass	3 µm/stainless steel	0.1 µm/glass fiber
Operating pressure max.	4 bar g		
Operating temperature max.	180 °C [356 °F] (for filter up to max. 350 °C [662 °F] see data sheet "Electrically Heated Filter Type FSS-2K/H350, FSS-3SS/H350 and FSS-FW/H350")		
Ambient temperature max.	50 °C [122 °F]		
Stagnant space	65 cm <sup>3</sup>		
Filter surface	70 cm <sup>2</sup>		
Power supply	230/240 V, 50 Hz, 350 VA or Part No. with (a)*: 115 V, 60 Hz		
Electrical connection	2.5 mm <sup>2</sup> terminals, 2 x PG13.5 cable glands		
Protection classification/electrical standard	IP 44 EN 60529/EN61010, EN 60519-1		
Temperature control	Thermostat (Pt100 optionally)		
Temperature adjustment	0 to 180 °C, [32 to 356 °F] (180 °C [356 °F] factory-set)		
Temperature alarm contact	Alarm point: ΔT 30 °C at T <sub>SET</sub> , contact rating: 250 V, 3 A~, 0.25 A =		
Dimension (W x H x D)	350 x 300 x 140 mm [≈ 13.8" x 11.8" x 5.5"]		
Weight	6 kg [≈ 13.2 lbs]		
Method of mounting	Wall-mounting		
Sample connections	G 1/4" i DIN ISO 228/1**		
Material of sample-contacting parts	PTFE, glass, FKM		

\* (a) is an addition to the Part No. for 115 V versions.

\*\* The thread lengths of the screw-in threads correspond to the respective applicable standard. The tolerances of the thread standards are matched to metal threads and cannot be applied to plastic threads.

Differential pressure in mbar with clean filter elements

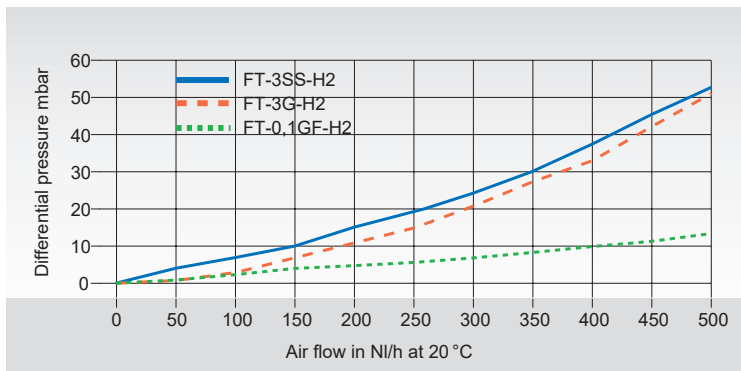

Please note: NI/h and NI/min refer to the German standard DIN 1343 and are based on these standard conditions: 0 °C [32 °F], 1013 mbar.



SP53-PP-2GF and SP52-PP-2GF

## Ambient Air Suction Filter Series SP®

Versions SP52-PP-2GF, SP52-PV-2GF, SP52-T-2GF, SP52-A/A-2GF and SP52-SS-20T without splash-proof sleeve

Versions SP53-PP-2GF and SP53-T-2GF with splash-proof sleeve

### Special Features

- **Ultra-fine filtration**
- **Large active filter surface**
- **Various materials available**
- **Easy mounting**
- **Straightforward maintenance**

### Application

M&C ambient air filters SP52/SP53 are used for filtration of ambient air in gas analyzing systems. The main applications are ambient air measurements and air conditioning systems.

### Description

The variable design of the M&C ambient air filters SP52/SP53 allows a perfect adaptation to local conditions. Filter body and filter element are available in various materials and filter porosities.

The open design allows the degree of filter contamination to be viewed at all times and ensures straightforward filter change without having to use tools.

Wall-mounting is carried out by means of 2 screws in the filter flange. The acrylic glass protective sleeve on version SP53 serves as splash water protection.

Ambient air suction filter SP52

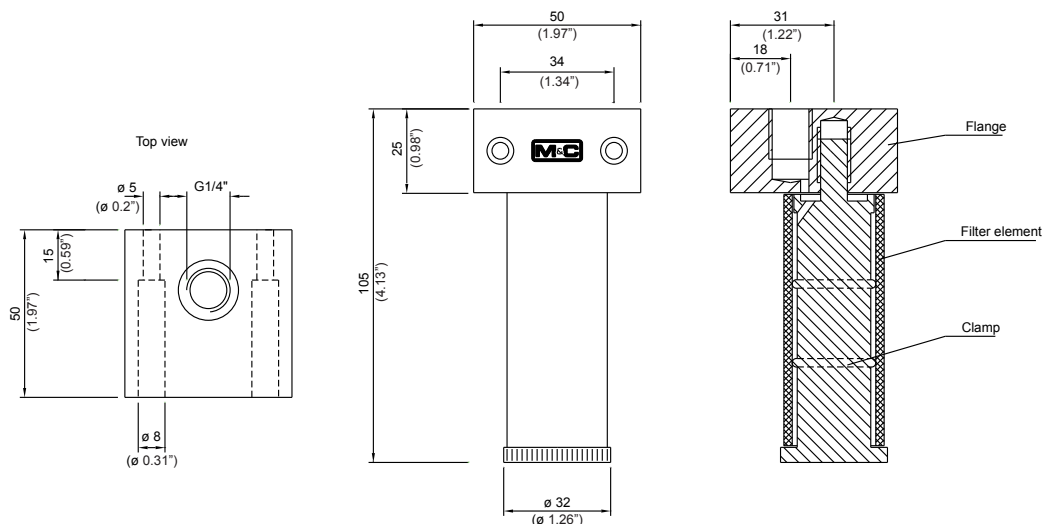

Ambient air suction filter with splash-proof sleeve SP53

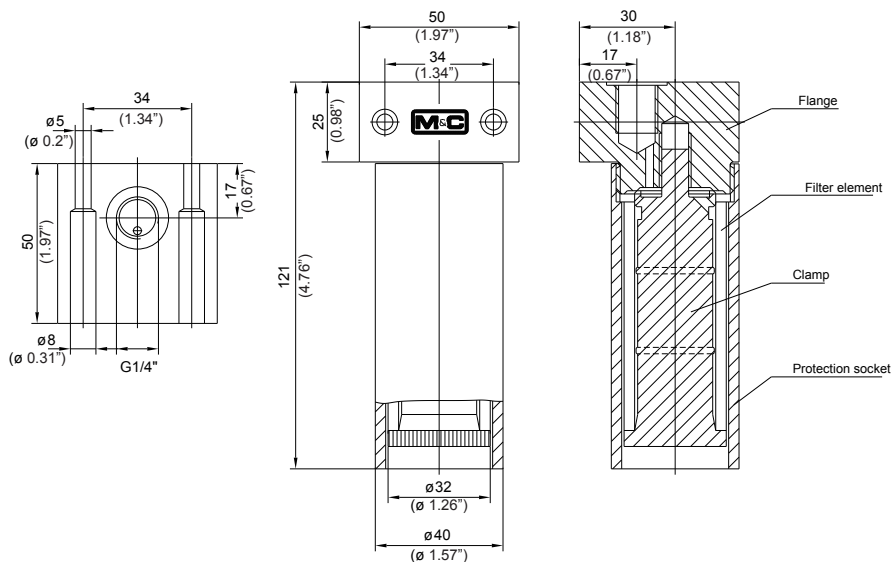

Dimensions in mm (inch)

Technical Data

Filter Type	SP52-PP-2GF	SP52-PV-2GF	SP52-T-2GF	SP52-A/A-2GF	SP52-SS-20T	SP53-PP-2GF	SP53-T-2GF
Part No.	04S1000	04S1100	04S3000	04S2000	04S4000	04S6000	04S6100
Protect. sleeve						Acrylic glass	
Filter element	F-2GF, 2 µm glass fiber				F-20T, 20 µm PTFE	F-2GF, 2 µm glass fiber	
Flange	PP	PVDF	PTFE	Al. anodized	Stainless steel 316Ti	PP	PTFE
Clamp	PP	PVDF	PTFE	Al. anodized	Stainless steel 316Ti	PP	PTFE
Temperature, max.	60 °C [140 °F]	80 °C [176 °F]	100 °C [212 °F]	180 °C [356 °F]	160 °C [320 °F]	60 °C [140 °F]	100 °C [212 °F]
Flow, max.	500 l/h [≈ 8.3 l/min]						
Diff. Pressure	35 mbar				55 mbar	35 mbar	
Connection	1 x G 1/4" i DIN ISO 228/1						
Dimensions (W x H x D)	50 x 50 x 105 mm [≈ 2.0" x 2.0" x 4.1"]					50 x 50 x 121 mm [≈ 2.0" x 2.0" x 4.8"]	
Weight	100 g [≈ 0.2 lb]	200 g [≈ 0.4 lb]	220 g [≈ 0.5 lb]	280 g [≈ 0.6 lb]	800 g [≈ 1.8 lb]	130 g [≈ 0.3 lb]	250 g [≈ 0.5 lb]

Other materials or filter porosities upon request.