

Product Group Liquid Alarm Sensors.

Product Category Process Control.





LA1S

Liquid Alarm Sensors Series LA® for Conductive Media

Version LA1S, LA25S and flow chambers LS, LS25 as well as LA1 and LA25 for use in hazardous areas

Special Features

- **Reliable detection even of minimal liquid quantities**
- **Line-break monitoring for LA1S and LA25S**
- **Integrable in M&C universal filters and flow chambers**
- **Also versions for higher pressure and temperatures**
- **No electrolytic effects on the sensor surface**
- **High chemical resistance**
- **Cable length up to 100 m [≈ 328.1 ft]**

Application

Liquid alarm sensors are used in gas conditioning systems to monitor gas cooling and condensate drains in order to protect downstream analytical instruments. This simple monitoring device reliably signals a condensate ingress in the event of a defect in cooling units or condensate drains and prevents expensive downtimes as well as high repair costs for analysis equipment.

In the event of an alarm, the sample gas pump or a shut-off solenoid valve in the conditioning system must be disconnected from the power supply.

Description

The M&C liquid alarm sensors LA...S operate according to the principle of electrical conductivity from a conductance value of 50 µS/cm. In order to prevent electrolytic effects on the sensor surface, the sensors are operated with alternating voltage.

The required evaluation electronics LA-1.1 and LA-1.4 are available in various designs and are described in the separate data sheet "Electronic controllers series LA®". For the M&C liquid sensors LA...S, only the electronic controllers as of year of construction 04/2006 described in this data sheet can be used.

The M&C liquid alarm sensors LA...S are designed in such a way that any liquid droplets in the sample gas flow reach the sensor surface directly due to gravity and even the smallest droplets trigger a safe and fast alarm.

The LA1S sensor is designed for operating pressures up to 4 bar and the LA25S sensor up to 25 bar. They comply with protection class IP65 EN 60529.

The LA1S sensor with its 12 mm ø glass body is mounted in the GL connection of a universal filter F...-D or in the LS flow chamber.

The LA25S sensor has a 1/4" special screw-in fitting for mounting in the FSS...-D universal filters or for mounting in 8 mm ø tubes using a special T-fitting LS25.

With the universal filters and the flow chamber, the gas inlet and outlet can be rotated 180° during installation.

For hazardous areas, the sensors LA1 and LA25 of the old series can be used without line-break monitoring, as these are simple components. However, these may only be used with approved evaluation electronics, e.g. ER142 Ex (Part No. 03E2009 for 230 V or 03E2009a for 115 V) for intrinsically safe supply of the sensor.

Dimensions



Liquid sensors LA1S, LA25S, LA1 and LA25

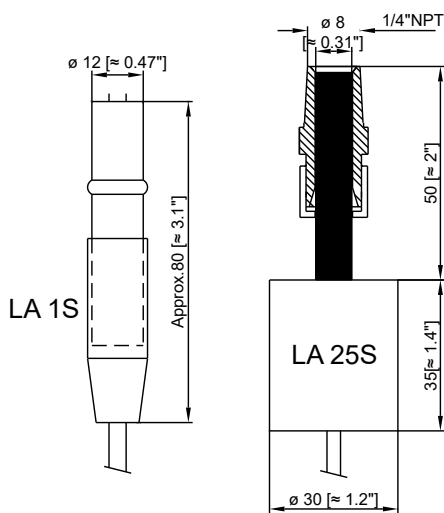

Dimensions in mm [Inches]

Liquid sensors LA1S and LA25S in universal filter F...-D and FSS...-D

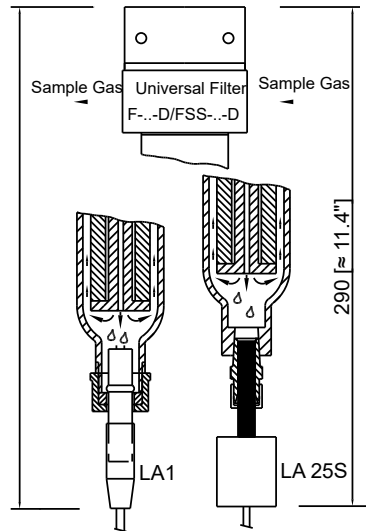

Liquid alarm sensors LA1S and LA25S with flow chamber LS and LS25

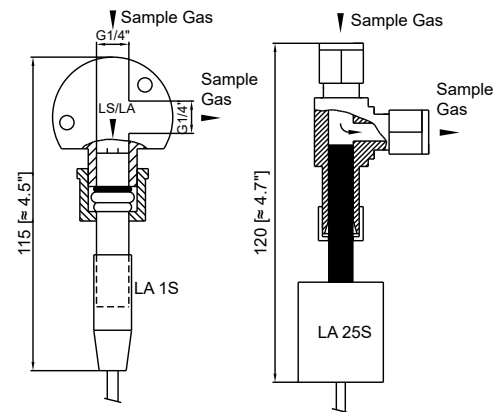

Technical Data Liquid Alarm Sensor

Sensor Series LA*	LA1S with cable break monitoring	LA1 (former version)	LA25S with cable break monitoring	LA25 (former version)
Part No.	03E1001	03E1000	03E1111	03E1110
Connection cable	4 m [≈ 13.1 ft] length, diameter: ø 4.2 mm, 2-core, each additional meter: Part No. 03E9001, total max. 100 m [≈ 328.1 ft]	4 m [≈ 13.1 ft] length, diameter: ø 2 mm, 2-core, each additional meter: Part No. 03E9000, total max. 100 m [≈ 328.1 ft]		
Pressure	2 bar g inside universal filter, 0 to 4 bar g inside flow chamber		0 to 25 bar g* (up to 100 bar g*) inside universal filter and inside flow chamber	
Operating temperature max.	+80 °C [176 °F] ***			
Installation connection	ø 12 mm for GL 25 nut and GL 25- 12 mm sealing ring		1/4" NPT a	1/4" NPT a
Material of sample-contacting parts***	Glass, platinum	Glass, platinum	SS 316Ti PVDF	SS 316Ti PVDF
Type of mounting	Clamping attachment	Clamping attachment	Screw-on	Screw-on
Mounting position	Vertical			
Electrical conductivity	> 50 µS/cm			
Weight	50 g [≈ 0.1 lb]	50 g [≈ 0.1 lb]	140 g [≈ 0.3 lb]	140 g [≈ 0.3 lb]
Cable break monitoring	Yes	No	Yes	No
Operating in Ex areas	No	Yes	No	Yes

* Other pressure ranges -, ** Other dimensions -, *** Other materials or temperatures on request

Technical Data Flow Chamber

Flow Chamber Series LS	LS for LA1S and LA1 (former version)	LS25 for LA25S and LA25 (former version)
Part No.	03E3100	03E1120
Pressure	0 to 4 bar	0 to 25 bar g* (up to 100 bar g*)
Flow rate	0 to 1000 l/h	
Operating temperature max.	+80 °C ***	
Gas connections	G 1/4" i	ø 8 mm **
Stagnant space	Approx. 3 ml	
Material of sample-contacting parts***	PVDF, FKM	SS 316Ti
Type of mounting	Wall-mounting	Tube line
Mounting position	Vertical, the mounting position of the liquid sensor is vertical	
Weight	60 g	100 g
Operating in Ex areas	Yes	Yes

* Other pressure ranges -, ** Other dimensions -, *** Other materials or temperatures on request

Part numbers for combined filters or flow chamber sets including sensor and electronic controllers can be taken from the current list of items.



LA-1.1, LA-1.4

Electronic Controllers Series LA®

Version LA-1.1, LA-1.4

Special Features

- 2 mounting types
- Cable break monitoring
- 2 potential free change-over contacts
- Configurable alarm reset
- LEDs for displaying operational and fault status
- For max. 100 m sensor cable as standard
- Switching point adjustable

Application

The LA-1.1 and LA-1.4 electronic controllers are used for power supply and signal processing of the liquid alarm sensors LA1S and LA25S.

Description

Two installation types are available: LA-1.1 for wall-mounting and LA-1.4 for rail-mounting.

Cable break monitoring is integrated for reliable operation. There are two LEDs for displaying the operational and fault status as well as two potential-free changeover contacts with "safety-first" circuit for safe alarm signaling. The electronic controllers are equipped with an alarm reset that may be activated or deactivated. Upon delivery, it is not activated.

By using one of the contacts, a pump or a solenoid valve of the gas conditioning system can be directly connected and the second contact can be used as a status alarm.

The switching point of the electronic controllers LA-1.1 and LA-1.4 is adjustable via a potentiometer. A standard adjustment is carried out at the factory.

The special electronic controller ER142 Exi (Part No: 03E2009/a) without cable break monitoring is for the intrinsically safe supply of the LA1 and LA25 sensor (old series!) located in a hazardous area.

LA-1.1 in wall-mounting housing

LA-1.4 in rail-mounting housing

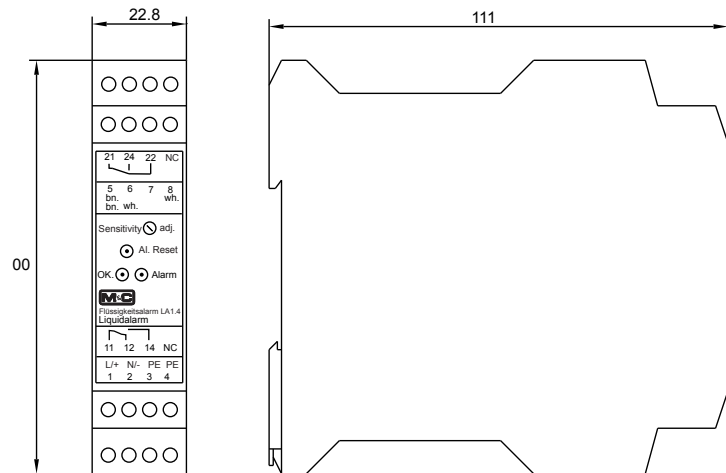
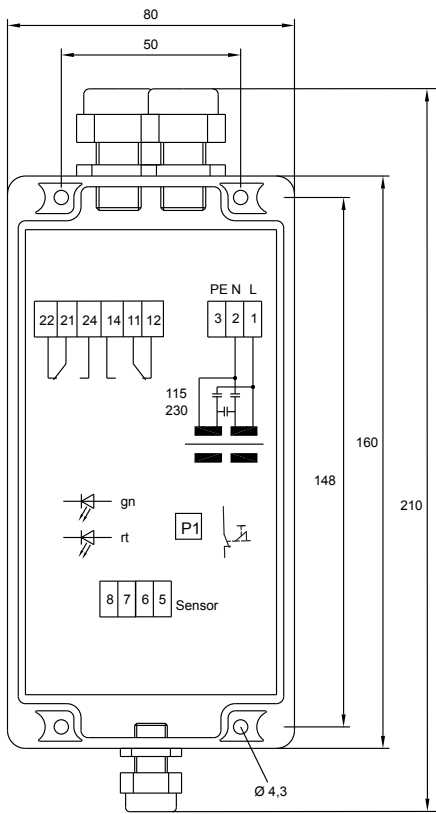

Dimensions in mm

Technical Data

Electronic controllers type	LA-1.1	LA-1.4
Part Number		
230 V 50/60 Hz	03E2001*	03E2006
115 V 50/60 Hz	03E2001*	03E2006 a
24 V DC	03E2001 d	03E2006 d
24 V AC	03E2001 b	03E2006 d
Mounting	Wall-mounting housing	Rail-mounting housing EN 50022
Sensor inlets	1	
Power consumption	2 VA	1 VA
Alarm relay (2x MC/NC/NO)	250 V DC/AC	250 V AC/DC
Contact rating	DC = 50 W, AC = 500 VA, 3 A	DC = 45 W, AC = 500 VA, 2 A
Cable inlet	1 x terminals 3 to 6.5 mm 2 x terminals 5 to 10 mm	
Electrical connection	Terminals max. 2,5 mm ²	
Adjustment of switching point	Via potentiometer after opening of housing	Via potentiometer in the housing front
Distance between sensor and electronic LA-1..	Max. 100 m [≈ 328.1 ft]	
Cable break monitoring	Yes	
Alarm reset**	Yes	
Protection type	IP65 EN 60529	IP20 EN 60529
Housing material	Polycarbonate	Polyamide PA 6.6 combustibility class VO (UL94)
Ambient temperature	-25 to +60 °C [-13 to 140 °F]	
Dimensions (W x L x H)	80 x 160 x 55 mm [≈ 3.2" x 6.3" x 2.2"]	22.8 x 100 x 111 mm [≈ 0.9" x 3.9" x 4.4"]
Weight	0,31 kg [≈ 0.7 lb]	0,23 kg [≈ 0.5 lb]

* Reversible distribution voltage 230V 50 Hz /115 V 60 Hz, at works adjusted to 230 V 50 Hz.

** deactivated at works



KS3

Liquid Alarm Sensor

KS3/KS3 EX, KS3 EX PEEK, KS3 EX PEEK SS, KS3 EX SS

for non-conductive and conductive media

Special Features

- **Reliable detection even of minimal liquid quantities**
- **Can be integrated into M&C universal filters and flow chamber**
- **ATEX certified versions for hazardous zone 1 areas**
- **Rugged aluminium enclosure**
- **Extended operating temperature range from -20 to 50 °C [-4 to 122 °F] for Ex versions**

Application

The liquid alarm sensor type KS3... is an adequate replacement for the previous KS2... model. The KS3... has a rugged aluminium enclosure. Additionally, the operating temperature range for the KS3 EX versions has been extended from -20 up to 50 °C [-4 to 122 °F] in connection with the renewed Type Examination Certificate.

Liquid alarm sensors are used in gas sample conditioning systems for monitoring gas cooling and condensate drains in order to provide protection for downstream analysis instruments. The monitoring devices KS3/KS3 EX versions reliably signal the penetration of non-conductive (e.g. alcohol) and conductive (e.g. water) liquid in the event of cooling or condensate drains being defective, thus avoiding expensive downtime as well as high repair costs for analysis instruments.

In the event of an alarm, power for the sample gas pump must be switched off or a solenoid valve must be switched idle in the sample conditioning system.

The M&C liquid alarm sensors KS3/KS3 EX versions are designed in such a way that any droplets of liquid in the sample gas are attracted directly to the active sensor surface. Even the smallest liquid droplets will trigger a reliable and rapid alarm.

The sensors are mounted with the 16 mm ø stainless steel body in the GL 25 connector of the universal filter F...-D or the condensate vessel TG1 or in the flow chamber LS/KS.

Description

The M&C liquid alarm sensors KS3/KS3 EX versions work on the principle of capacitive measurement and are suitable for non-conductive and conductive media. A pre-amplifier is integrated in the sensor housing and is connected with the necessary external electronic controller via 2- or 3-wire. For KS3, the required electronic controller is available in various versions: FA1.1 or FA1.4 and is described in the separate data sheet "Electronic Controller Series FA®".

The M&C liquid alarm sensors KS3 EX, KS3 EX PEEK, KS3 EX PEEK SS and KS3 EX SS for use in hazardous areas and media should only be used in connection with electronic controller KF8Ex1.

**KS3/KS3 EX, KS3 EX PEEK
liquid alarm sensor**

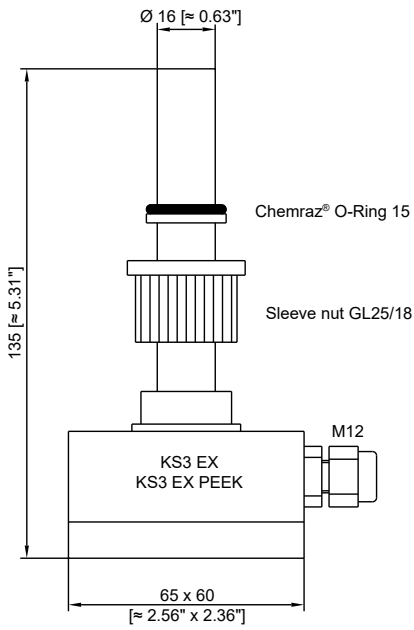

**KS3 EX PEEK SS, KS3 EX SS
liquid alarm sensor**

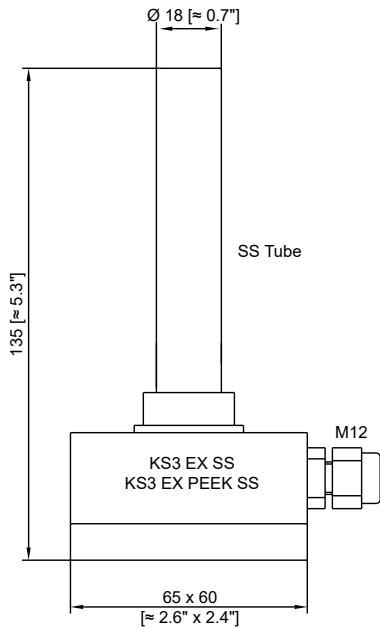

**Liquid alarm sensor KS3/KS3 EX,
KS3 EX PEEK, KS3 EX PEEK SS, KS3 EX SS
in a universal filter F...-D**

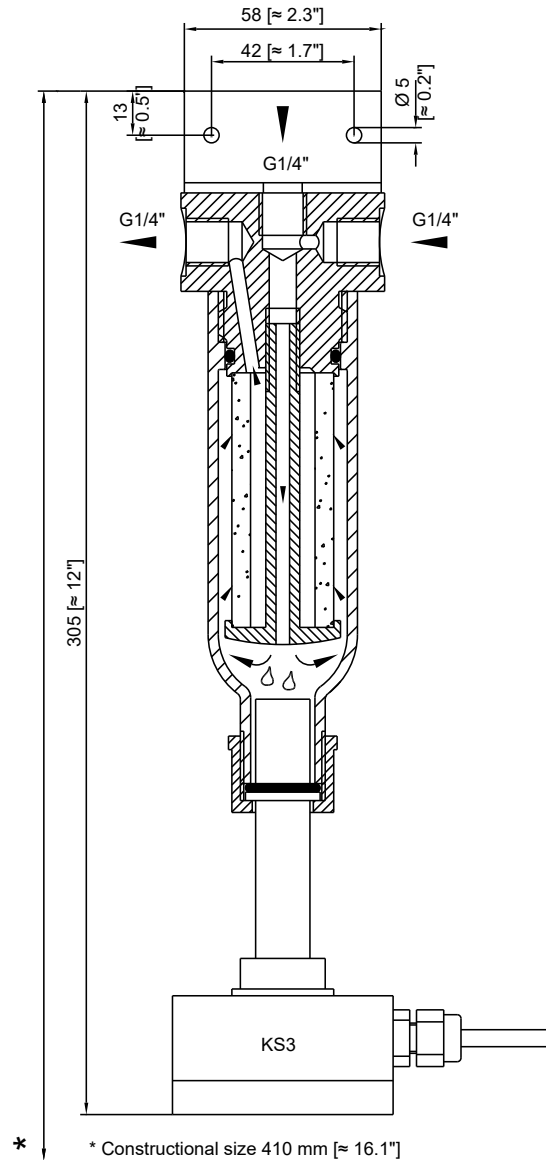

In the event of condensate penetration, the filter housing acts as a buffer vessel preventing immediate liquid ingress.

**KS3... liquid sensor for filling level
monitoring in condensate vessel TG1**

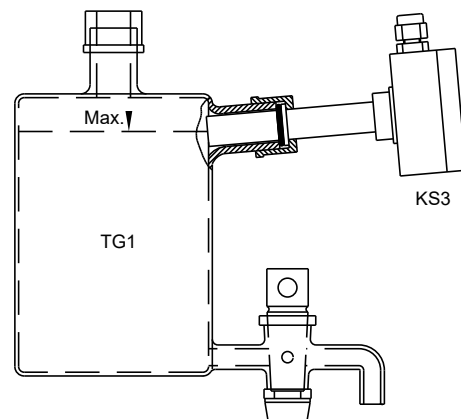

Dimensions in mm [Inches]

Sensor	KS3	KS3 Peek	KS3 SS	KS3 Peek SS
Part No.	03E4150	03E4160	03E4170	03E4180
Pressure	Max. 2 bar abs.	Max. 11 bar abs.	Max. 2 bar abs.	Max. 11 bar abs.
Max. operating temperature	-20 bis +60 °C* [-4 to 140 °F]*			
Liquid alarm limit	1.5 ml			
Material of sample-contacting parts	PTFE, Chemraz®, SS 316Ti	Peek, Chemraz®, SS 316Ti	PTFE, Chemraz®, SS 316Ti	Peek, Chemraz®, SS 316Ti
Sample connection standard (Fitting for mounting in stainless steel filter: connector GE SS ½" NPT - 18 mm Part No. 09V2317)	ø 16 mm for GL25	ø 16 mm for GL25	ø 18 mm for mounting inside stainless steel filter FSS...-D with 1/2" NPT	ø 18 mm for mounting inside stainless steel filter FSS...-D with 1/2" NPT
Method of mounting/mounting position	Clamping attachment/for liquid alarm vertical mounting position with opening facing upwards			
Power supply	8-12 V DC, feeding via FA1.1 or FA1.4			
Connection cable, length 1.5 m [≈ 4.9 ft] standard	3 x 0.34 mm ²			
Cable	Capacity Inductivity	200 pF/m 1 µH/m		
Protection	IP54 EN 60529			
Weight	230 g [≈ 0.6 lb]		260 g [≈ 0.6 lb]	
Evaluation electronic	FA1.1 or FA1.4 (see data sheet "Electronic Controller Series FA")			

* To specify the minimum operating temperature, the freezing point of the condensate needs to be considered.

Chemraz® is a registered trademark for perfluoroelastomer by Greene Tweed, USA.

Technical Data Sensors for EX Areas

Sensor	KS3 EX	KS3 EX Peek	KS3 EX SS	KS3 EX Peek SS
Part No.	03E4250	03E4260	03E4270	03E4280
Pressure	Max. 2 bar abs.	Max. 11 bar abs.	Max. 2 bar abs.	Max. 11 bar abs.
Max. operating temperature	-20 to +50 °C* [-4 to 122 °F]*			
Liquid alarm limit	1.5 ml			
Material of sample-contacting parts	PTFE, Chemraz®, SS 316Ti	Peek, Chemraz®, SS 316Ti	PTFE, Chemraz®, SS 316Ti	Peek, Chemraz®, SS 316Ti
Sample connection standard (Fitting for mounting in stainless steel filter: connector GE SS ½" NPT - 18 mm Part No. 09V2317)	ø 16 mm for GL25	ø 16 mm for GL25	ø 18 mm for mounting inside stainless steel filter FSS...-D with 1/2" NPT	ø 18 mm for mounting inside stainless steel filter FSS...-D with 1/2" NPT
Method of mounting/mounting position	Clamping attachment/for liquid alarm vertical mounting position with opening facing upwards			
Max. voltage/current/power consumption	13.5 V/31 mA/125 mW			
Internal capacity max.	150 nF			
Internal inductivity max.	0 mH			
Power supply	8 V DC/max. 2.4 mA during operation: < 1.4 mA alarm			
Connection cable, length 1.5 m [≈ 4.9 ft] standard	2 x 0.25 mm ²			
Cable	Capacity Inductivity	200 pF/m 1 µH/m		
Marking/certificate No.	Ⓔ II 2G Ex ia IIC T6 Gb (if mounted inside a filter or a condensate vessel: Ⓔ II 2G Ex ia IIB T6 Gb) BVS 16 ATEX E 127 IECEx BVS 16.0092			
Weight	230 g [≈ 0.5 lb]		260 g [≈ 0.6 lb]	
Evaluation electronic	KFU8Ex1 with broadband power supply 90-253 V AC, part No. 01U2502			

* To specify the minimum operating temperature, the freezing point of the condensate needs to be considered.

Chemraz® is a registered trademark for perfluoroelastomer by Greene Tweed, USA.