

# Product Group Oxygen Analyzers.

Product Category Gas Analysis.





PMA10

## Oxygen Analyzer Series PMA®

Portable version PMA10  
for mobile oxygen measurement

### Special Features

- Portable and rugged instrument, lightweight design
- Analog and digital display, linear measuring ranges
- Physical measuring principle
- Small dead volume, fast response time
- High accuracy and reliability
- Approved according to DIN EN 14181 as well as to 13th and 17th BImSchV and TA-Luft certificate optionally

### Application

Due to the very fast response time, the magneto-dynamic measuring cell, the small dead volume and the low cross-sensitivity to other measuring gas components, the portable M&C oxygen analyzer PMA10 has a wide range of applications.

It is an ideal and reliable instrument for oxygen measurement in flue gases, inerting plants, fruit storage facilities, protective gas packaging machines, fermentation processes, ambient air monitoring equipment, etc.

### Description

The non-heated M&C oxygen analyzer PMA10 is suitable for discontinuous and continuous oxygen measurements in dry and particle-free gases.

The PMA10 is reliable, easy to use and immediately ready for operation. It has a compact design in a portable housing. The analog display with 30- and 100 vol%-scale indicates the 4 switchable measuring ranges, the 3 1/2-digit digital display always shows the measuring range from 0 to 100 vol% O<sub>2</sub>. A signal output is available. Sample gas connections and signal output are located at the front of the analyzer, mains and optional alarm contact connection are at the rear. The sample gas enters the analyzer via the protective filter. The flow rate is adjusted at the front flow meter with a needle valve. Then, the sample gas flows through the M&C measuring cell to the gas outlet.

Optional features include O<sub>2</sub> alarm, battery for mains-independent operation and internal mini-pump.

### The Measuring Principle of the M&C Oxygen Analyzer

The PMA10 applies a physical measuring principle to measure the oxygen content and uses the magneto-dynamic M&C measuring cell. The measuring method is based on the very high paramagnetic susceptibility of oxygen, which almost exclusively possesses this feature.

The cross-flow measuring cell is characterized by robustness, extremely low drift, only 2 ml dead volume, fast response time and low cross-sensitivity to other gases. The measuring method is one of the most accurate quantitative determination methods for oxygen in the range from 0 to 100 vol%.

When used correctly, the M&C measuring cell has a very long service life. A diamagnetic dumbbell with a mirror at its pivot point is attached to band clamps and mounted in an inhomogeneous magnetic field. Due to its paramagnetism, the oxygen strives into the inhomogeneous magnetic field of the measuring cell. The O<sub>2</sub> molecules exert a torque on the dumbbell and deflect it. The optical scanning electronically induces a current which flows through a feedback coil on the dumbbell and resets it to a neutral position. The compensation current is proportional to the oxygen content of the sample gas, thus rendering the O<sub>2</sub> display absolutely linear.

# Gas flow diagram PMA10



- 1. Fine filter
- 2. Flow meter with needle valve
- 3. Oxygen measuring cell PMA
- 4. Option mini-pump

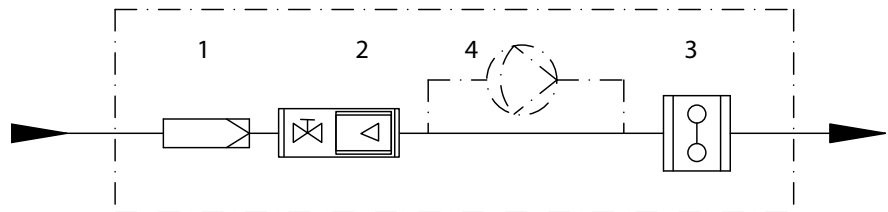

## Dimensions

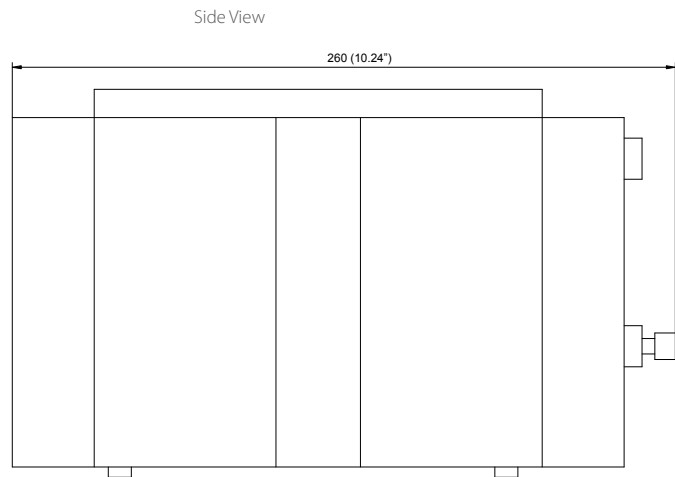
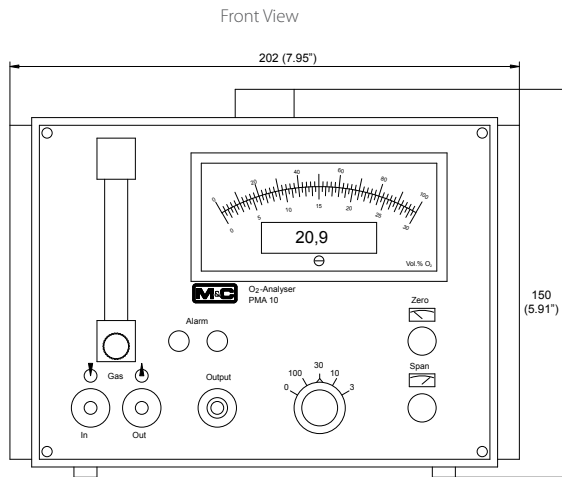

Dimensions in mm [inch]

Version PMA10 Portable Oxygen Analyzer	
Part No.	01A1000: PMA10, power supply 230 V/50 Hz, output signal 0-1 V; 01A1000a = 115 V/60 Hz
Measuring ranges	Selectable for 0-3, 0-10, 0-30 and 0-100 vol% O <sub>2</sub> , linear
Indication	Analog/digital meter: Analog meter selectable for each range with a scale of 0-30 and 0-100 vol% digital meter, 3 1/2-digit 9 mm [≈ 0.4"] high LCD for 0-100 vol% O <sub>2</sub> reading, selectivity 0.1 vol% O <sub>2</sub>
Output signal	0-1 V DC, non-isolated, load > 100 kΩ, for each selected range; option: 0-20 mA* or 4-20 mA* for each selected range, non-isolated, max. load 300 Ω, Part No. 01A9000
Response time for 90 % FSD	< 3 seconds at 60 NI/h air
Accuracy after calibration	Analog = ± 1 % of span/digital = ± 0.1 vol% O <sub>2</sub> deviation
Reproducibility	Analog = < 1 % of span/digital = ± 0.1 vol% O <sub>2</sub> deviation
Influence of ambient temperature	Zero point ± 0.02 vol% O <sub>2</sub> /°C; sensitivity ± 0.1 vol% O <sub>2</sub> /°C
Influence of barometric pressure	The oxygen reading varies in direct proportion to changes of the barometric pressure.
Influence of sample gas flow	Variation in gas flow between 0-60 NI/h air will cause a difference of < 0.1 vol% O <sub>2</sub> .
Sample gas inlet pressure	0.01 up to 1 bar g, (PMA10 required admission pressure for adequate flow rate, no pump inside) option: PMA10 with internal pump, capacity 0.9 NI/min. without pressure, Part No.: 01A9102
Sample gas outlet pressure	Outlet of analyzer must discharge freely into atmosphere.
Flow rate of sample gas	Max. 60 NI/h air, adjustable with needle valve on the flow meter 7-70 NI/h
Temperature of sample gas	-10 up to +40 °C [14 to 104 °F], dry gas
Analyzer temperature	According to ambient temperature, non-heated version
Ambient temperature	-10 up to +55 °C [14 up to 131 °F]
Storage temperature	-20 up to +60 °C [-4 up to 140 °F], relative humidity 0 to 90 % RH
Power supply	Internal power unit for 230 VAC standard or 115 VAC available (a)* +/- 10 %, 40-60 Hz, 8 VA option: rechargeable battery, recharged by the internal power unit, Part No. 01A9050 battery capacity 10 h, recharge time of battery 14 h with instrument off
Electrical connections	Power supply: 3-pole chassis plug with 2 m cable; signal: 3-pole plug
Materials in contact with sample gas	Platinum, glass, polypropylene, stainless steel 316, FPM, epoxy resin
Sample gas connection	PP hose nipple for DN 11-4 mm tube
Protection/electrical standard	IP41 EN 60529/EN 61010
Housing/color	Portable plastic housing out of Makrolon®/gray
Dimension (H x W x D)	150 x 202 x 260 mm [≈ 5.9 x 8.0 x 10.2"]
Weight	Approx. 3 kg [≈ 6.6 lbs]
Alarms	Option: O <sub>2</sub> alarm low* or high* adjustable 0 to 100 vol% O <sub>2</sub> , relay contact NC/NO, Part No. 01A9150 additional with acoustic signal and auto-reset after 30 sec., Part No.: 01A9155 additional with acoustic signal and manual reset, Part No.: 01A9156
Certificate	Option: approved according to DIN EN 14181 as well as the 13th and 17th BImSchV and TA-Luft, Part No.: <b>01A9160</b>

\* Please specify with order.

The simultaneous installation of pump and alarm module is only possible in conjunction with a rechargeable battery.

The option "acoustic alarm" is only possible with the option "O<sub>2</sub> alarm".

Option "TÜV-approved" includes 0\*/4\*-20 mA signal output; in this case, only rechargeable battery and internal pump are available as options.

Please note: NI/h and NI/min refer to the German standard DIN 1343 and are based on these standard conditions: 0 °C [32 °F], 1013 mbar.

Makrolon® is a registered trademark for polycarbonates by Bayer AG, Germany.

**WARNING!**

**IMPORTANT!**

An external fine filter must always be used at the gas inlet of the analyzer. Depending on the composition of the sample gas, it may be necessary to use a sample conditioning system. Without precautions, the analyzer is only suitable for measuring non-flammable gases or gas mixtures in non-hazardous areas.



PMA20

## Oxygen Analyzer Series PMA®

Heated version PMA20  
in a wall-mount housing

### Special Features

- **Thermostated, in a wall-mounting housing**
- **Small space requirements**
- **Accurate and reliable**
- **Analog indicator, linear measuring ranges**
- **Physical measuring principle**
- **Small dead volume, fast response time**
- **Maximum operating reliability**
- **Approved according to DIN EN 14181 as well as to 13th and 17th BImSchV and TA-Luft certificate optionally**

### Application

Due to the very fast response time of the M&C magneto-dynamic measuring cell, the small dead volume and the low cross-sensitivity to other sample gas components, the M&C oxygen analyzer PMA20 is used in a wide variety of applications.

The analyzer is a suitable and reliable instrument for monitoring oxygen concentrations in various analytical gas control applications including flue gas-, inert gas-, ambient air-, fermentation processes or laboratory measurements.

### Description

The heated M&C oxygen analyzer PMA20 is suitable for continuous oxygen measurements in dry and particle-free gases.

The PMA20 is reliable and easy to use. It is compactly designed in a wall-mounted housing with lockable door. The transducer unit maintains a constant temperature of 50 °C [122 °F] which is indicated by a flashing LED at the front. The analog meter with 30- and 100-vol%-scale shows the 4 switchable measuring ranges. Two signal outputs are also available. Sample gas connections and terminals for mains connection and signal outputs are in the lower connection section of the housing.

The sample gas enters the analyzer via the external ultra-fine filter. The required flow rate is adjusted at the flow meter with a needle valve at the front. Then, the sample gas flows through the M&C measuring cell to the gas outlet.

Optionally available: certificate according to DIN EN 14181 or 13th and 17th BImSchV as well as TA-Luft or chlorine-resistant version.

### The Measuring Principle of the M&C Oxygen Analyzer

The PMA20 applies a physical measuring principle to measure the oxygen content and uses the magneto-dynamic M&C measuring cell. The measuring method is based on the very high paramagnetic susceptibility of the oxygen, which has this property almost exclusively.

The cross-flow measuring cell is characterized by robustness, extremely low drift, only 2 ml dead volume, fast response time and low cross-sensitivity to other gases. The measurement method is one of the most accurate quantitative determination methods for oxygen in the range from 0 to 100 vol%.

When used correctly, the M&C measuring cell has a very long service life. A diamagnetic dumbbell with a mirror at its pivot point is attached to band clamps and mounted in an inhomogeneous magnetic field. Due to its paramagnetism, the oxygen strives into the inhomogeneous magnetic field of the measuring cell. The O<sub>2</sub> molecules exert a torque on the dumbbell and deflect it. The optical scanning electronically induces a current which flows through a feedback coil on the dumbbell and resets it to the neutral position.

The compensation current is proportional to the oxygen content of the sample gas, rendering the O<sub>2</sub> display absolutely linear.

# Gas Flow Diagram PMA20



- 1. External fine filter
- 2. Flow meter with needle valve
- 3. Oxygen measuring cell PMA

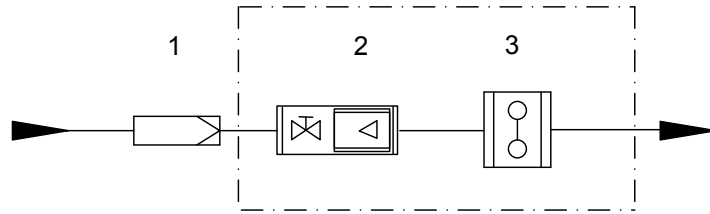

## Dimensions

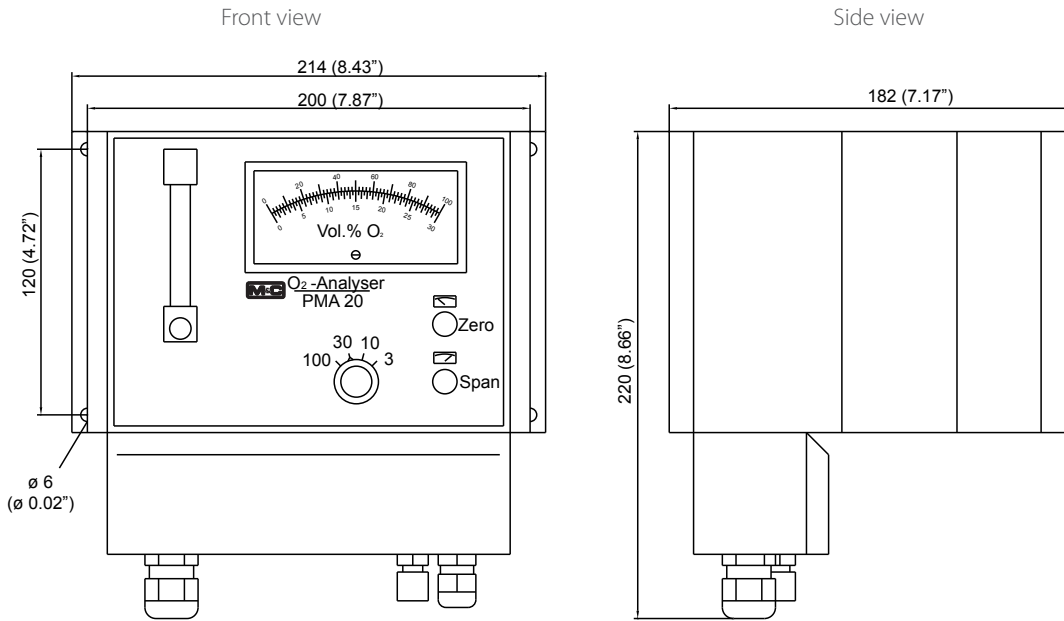

Dimensions in mm [inch]

Version PMA20 Heated Oxygen Analyzer in a Wall-Mounting Housing	
Part No.	02A1000: PMA20, power supply 230 V/50 Hz, signal 0-1 V + 0-20 mA; 02A1000a = 115 V/60 Hz
Measuring ranges	Selectable for 0-3, 0-10, 0-30 and 0-100 vol% O <sub>2</sub> , linear
Indication	Analog meter with a scale of 0-30 and 0-100 vol% for each selected range option: combined analog/digital meter: analog meter with a scale of 0-30 and 0-100 vol% for each selected range, digital meter, 3 1/2-digit 9 mm high LCD-indicator for 0-100 vol% O <sub>2</sub> reading, selectivity 0.1 vol% O <sub>2</sub> or digital meter 3 1/2-digit 18 mm high LCD for 0-100 vol% O <sub>2</sub> reading, selectivity 0.1 vol% O <sub>2</sub> , Part No.: 02A9000
Output signals	0-1 V DC non-isolated, load > 100 kΩ, for the range of 100 vol%, and 0-20 mA or 4-20 mA* for the chosen range, non-isolated, max. load 300 Ω
Response time for 90 % FSD	< 3 seconds at 60 NI/h air
Accuracy after calibration	Deviation: analog = ±1 % of span/digital = ±0.1 vol% O <sub>2</sub>
Reproducibility	Deviation: analog = < 1 % of span/digital = ±0.1 vol% O <sub>2</sub>
Influence of ambient temperature	No influence up to 45 °C [113 °F]
Influence of barometric pressure	The oxygen reading varies in direct proportion to changes of the barometric pressure.
Influence of sample gas flow	Variation in gas flow between 0-60 NI/h air will cause a difference of < 0.1 vol% O <sub>2</sub>
Sample gas inlet pressure	0.01 up to 1 bar g, (PMA20 required admission pressure for adequate flow rate, no pump inside)
Sample gas outlet pressure	Outlet of analyzer must discharge freely into atmosphere
Flow rate of sample gas	Max. 60 NI/h air, adjustable with needle valve on the flow meter 7-70 NI/h
Temperature of sample gas	-10 up to +40 °C [14 to 104 °F] dry gas
O <sub>2</sub> transducer temperature	Set to +50 °C [122 °F] at the factory
Ambient temperature	-10 up to +45 °C [14 °F up to 113 °F]
Storage temperature	-20 up to +60 °C [-4 °F up to 140 °F], relative humidity 0 to 90 % RH
Power supply	Internal power unit for 230 V <sub>AC</sub> standard or 115 V <sub>AC</sub> available (a)* +/-10 %, 40-60 Hz, 26.5 VA
Electrical connections	Terminals 2.5 mm <sup>2</sup> ; 1 x PG11, 1 x PG13.5 cable gland
Materials in contact with sample gas	Platinum, glass, polypropylene, stainless steel 316Ti, FPM, epoxy resin
Sample gas connection	PP hose connectors DN 4/6 for 4 mm i.d. and 6 mm o.d. tube
Protection/electrical standard	IP53 EN 60529/EN 61010
Housing/front color	Plastic wall-mounting housing out of Makrolon®/blue-grey
Dimensions (H x W x L)	220 x 214 x 182 mm [≈ 8.7 x 8.4 x 7.2"]
Weight	Approx. 3 kg [≈ 6.6 lbs]
Certificate	Option: approved according to DIN EN 14181 resp. to 13th and 17th BImSchV and TA-Luft, Part No.: <b>02A9010</b>

\* Please specify with order.

Please note: NI/h and NI/min refer to the German standard DIN 1343 and are based on these standard conditions: 0 °C [32 °F], 1013 mbar. Makrolon® is a registered trademark for polycarbonates produced by Bayer AG, Germany.

## WARNING! IMPORTANT!

An external fine filter must always be used at the gas inlet of the analyzer. Depending on the composition of the sample gas, it may be necessary to use a sample conditioning system. Without precautions, the analyzer is only suitable for measuring non-flammable gases or gas mixtures in non-hazardous areas.



PMA50 EX

## Oxygen Analyzer Series PMA®

Version PMA 50 EX

Heated, in an explosion-proof wall-mount housing



### Special Features

- ATEX certified versions for hazardous zone 1 areas
- SIL approval according to DIN EN 61508
- Thermostated, in an explosion-proof housing
- Accurate and reliable, small space requirements
- Analog/digital indicator, linear measuring ranges
- Physical measuring principle
- Small dead volume, fast response time
- Remote measuring range indication and selection
- Flow alarm sensor in the outlet
- Status alarm, maximum operating reliability

### Application

Due to the extremely fast response time, the small dead volume, the paramagnetic M&C measuring cell as well as the negligible cross-sensitivity to other sample gas components, the M&C oxygen analyzer PMA 50 EX is a reliable instrument for measuring oxygen concentrations in a wide range of applications.

### Description

The heated M&C Oxygen Analyzer PMA 50 EX is suitable for continuous oxygen measurements in dry and particle-free gases with a flow rate from 0 to 60 NI/h.

The PMA50 EX is reliable and easy to operate. It is designed in a pressure-resistant, explosion-proof wall-mounted housing EX d IIC T4 with stainless steel tubing and certified breathing and draining devices at the sample gas inlet and outlet.

The thermostat is set to 55 °C [131 °F] which is indicated by a flashing LED on the front panel. The analog meter with the 30- and 100- vol%-scale shows the 5 switchable measuring ranges, the digital display shows the 100-vol%-range. The pre-selected measuring range is indicated at the front via LED. The connection terminals for mains, 2 output signals, remote measuring range switching and remote detection as well as for the status contact are located in the EX e terminal box. The sample gas enters the analyzer via the breathing and draining devices downstream the gas conditioning with at least one ultra-fine filter and a flow meter with needle valve for adjusting the sample gas quantity (also available from M&C). It then flows through the M&C measuring cell, the flow sensor, to the breathing and draining device in the gas outlet.

### The Measuring Principle of the M&C Oxygen Analyzer

The PMA 50 EX applies a physical measuring principle to determine the oxygen concentration and uses the paramagnetic M&C measuring cell. The measuring method is based on the very high paramagnetic susceptibility of oxygen, which almost exclusively possesses this feature.

The flow-through measuring cell is characterized by robustness, extremely low drift, only 2 ml dead volume, fast response time and low cross-sensitivity to other gases. The measuring method is one of the most accurate quantitative determination methods for oxygen in the range from 0 to 100 vol%.

When used correctly, the M&C measuring cell has a very long service life. A diamagnetic dumbbell with a mirror at its pivot point is attached to suspension wires and mounted in an inhomogenous magnetic field. Due to its paramagnetism, the oxygen strives into the inhomogenous magnetic field of the measuring cell. The O<sub>2</sub> molecules exert a torque on the dumbbell and cause the dumbbell to rotate. The optical scanning electronically induces a current which flows through the wire loop around the dumbbell and rotates the dumbbell back to its neutral position.

The compensation current is proportional to the oxygen content of the sample gas, thus rendering the O<sub>2</sub> display absolutely linear.



# Gas Flow Diagram PMA 50 EX



1. External fine filter
2. External flow meter with needle valve
3. Breathing and draining device
4. Oxygen measuring cell PMA
5. Flow alarm sensor  
(and with option 05A9000 or 05A9005:  
with pressure sensor)

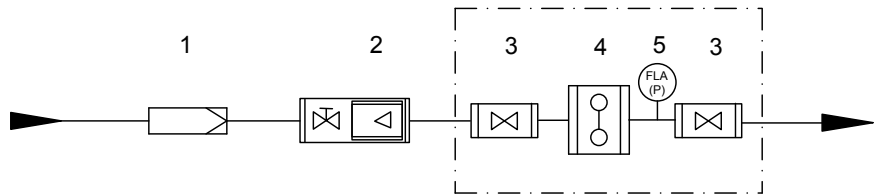

## Dimensions

1. Sample gas IN/OUT with certified breathing and draining devices
2. Cable glands 2 x M20 1 x M25
3. Zero-point control
4. Measuring range selection
5. Span control
6. Optional purging with certified breathing and draining devices

Side view

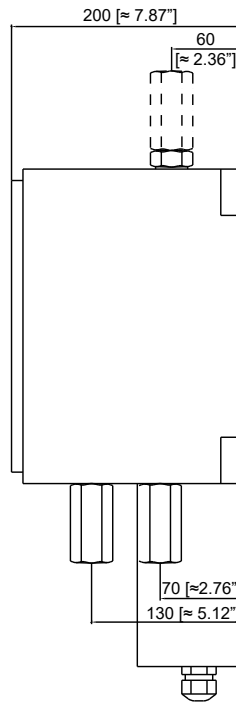

Front view

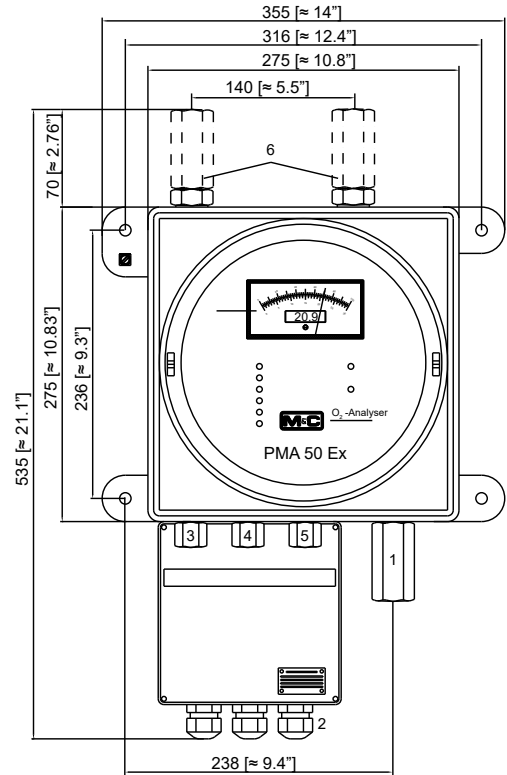

Dimensions in mm [inch]

Version PMA50 EX Thermostated Oxygen Analyzer in Explosion-Proof Housing		
Part No.	<b>05A1000:</b> <b>05A1000a:</b> <b>05A2500:</b>	<b>PMA50 EX</b> , power supply 230 V, pressure range 0.6 to 1.1 bar abs. <b>PMA50 EX</b> , power supply 115 V, pressure range 0.6 to 1.1 bar abs. <b>PMA50 EX/P/PD-1-50</b> , power 230 V (not with SIL certification) pressure compensation 0.6 to 1.5 bar abs. with purging the enclosure via breathing and draining devices in the in- and outlet NPT 1/4" i
	<b>05A2500a:</b>	<b>PMA50 EX/P/PD-1-50</b> , power 115 V (not with SIL certification) pressure compensation 0.6 to 1.5 bar abs. with purging the enclosure via breathing and draining devices in the in- and outlet NPT 1/4" i
	<b>05A2505:</b> <b>05A2505a:</b>	<b>PMA50 EX/P/PD</b> , power 230 V (not with SIL certification), pressure compensation 0.6 to 1.1 bar abs. <b>PMA50 EX/P/PD</b> , power 115 V (not with SIL certification), pressure compensation 0.6 to 1.1 bar abs.
	Power supply	230 V AC (standard) or 115 V AC (a)* -15 % to +10 %, 40 - 60 Hz, 35.5 VA
Electrical connections	Via Ex e connection box 3 x cable gland, cable diameter : 7 mm to 13 mm (M20), 14 mm to 18 mm (M25) terminals 0.5 to 2.5 mm <sup>2</sup> , tightening torque 0.6 Nm, (power, signals, range position and remote selection, status signal)	
Measuring ranges	Selectable for 0 to 1, 0 to 3, 0 to 10, 0 to 30 and 0 to 100 vol% O <sub>2</sub> linear, selection via turning selection switch at PMA50 EX or remote switching	
External range indication	One potential-free contact for each measuring range, switching capacity 48 V DC, 200 mA DC, minimum contact rating 5 V/1 mA	
Remote range selection	Measuring ranges selectable via potential-free contacts max. 30 V DC, 3 mA DC, the function is displayed at the PMA50 EX via LED	
Combined analog/digital indicator	Analog meter with 0 to 30 and 0 to 100 vol% scales for each selected range. Digital meter 4 1/2-digit 9 mm high LCD-indicator for 0 to 100 vol% O <sub>2</sub> measuring range, selectivity 0.01 vol% O <sub>2</sub>	
Output signals	0/4 to 20 mA, electrically isolated, burden 270 Ω for every measuring range; output voltage max. 15 V (factory setting), switchable max. burden 800 Ω, output voltage max. 30 V, output current limiting adjustable 20 mA to 22 mA, <b>factory setting: 20.5 mA</b> , 0 to 10 V DC, burden >100 KΩ for range 0 to 100 vol% electrically isolated.	
Response time for 90 % FSD	< 5 seconds at 60 NI/h air	
Accuracy after calibration	±1 % of of full scale value or ±0.02 vol% O <sub>2</sub> depending on which value is higher	
Reproducibility deviation	Analog output = < 1 % of measuring range/digital indication = ±0.1 vol% O <sub>2</sub>	
Influence of ambient temperature	No influence up to 50 °C [122 °F]	
Influence of barometric pressure	The oxygen reading varies in direct proportion to changes of the barometric pressure. With option 05A9000 or 05A9005 no influence from 0.6 to 1.5 bar abs. for version PMA 50 EX/P/PD(-1-50) with process pressure compensation	
Influence of sample gas flow	fluctuations of the sample gas flow in a range from 10 to 60 NI/h nitrogen (N <sub>2</sub> ) cause a change of the oxygen reading which is smaller than 0.1 vol% O <sub>2</sub>	
Sample gas inlet pressure	Standard max. 1.1 bar abs. or with option 05A9000 or 05A9005 up to 1.5 bar abs. for version with enclosure venting or purging. (minimum inlet pressure is required for necessary gas flow, PMA50 EX has no integrated pump)	
Sample gas outlet pressure	Outlet of analyzer must discharge freely into atmosphere or 0.6 - 1.5 bar abs. with version PMA 50 EX/P/PD(-1-50) with process pressure compensation	
Flow rate of sample gas	Min. 10 NI/h up to max. 60 NI/h adjustable externally via flow meter (PMA50 EX has no flow meter inside)	
Temperature of sample gas	-10 to +50 °C [14 to 122 °F] dry gas	
O <sub>2</sub> transmitter temperature	Set to at +55 °C [131 °F] at the factory	
Temperature cutoff	At 72 °C [161.6 °F] via thermal fuse, non-reversible	
Ambient temperature	0 to +50 °C [14 to 122 °F]	
Storage temperature	-20 to +60 °C [-4 to 140 °F] , relative humidity 0 to 90 % RH	
Sample-contacting parts	Platinum, glass, PTFE, PVDF, stainl. steel 316Ti, epoxy resin	
Sample gas connection	NPT 1/4" i	
Flow alarm	Thermo-conductive flow sensor downstream mounted after measuring cell	
Status alarm	Change-over contact, potential-free, switching capacity 250 V AC 2 A AC, 48 V DC, 200 mA DC minimum contact rating 50 mW for temperature < +45 °C [113 °F] / > +60 °C [140 °F], defect light beam, measuring cell not coupled, flow alarm < 5 NI/h/ > 80 NI/h, power supply error control, mains voltage breakdown	
Classification	II 2G Ex db eb IIC T4 Gb	
Protection class	IP54 EN 60529	
Housing/color	EX-d e explosion-proof wall-mounted housing/white	
Dimensions (H x W x D)	475 (535 with enclosure venting or purging) x 355 x 200 mm [≈ 18.7" (21.1" with enclosure venting or purging) x 14" x 7.9"]	
Weight	Approx. 22 kg [≈ 48.5 lbs]	
Certificate No.	IBExU 16 ATEX 1192 IECEx IBE 16.0041	

\* Please specify with order.

Please note: NI/h and NI/min refer to the German standard DIN 1343 and are based on these standard conditions: 0 °C [32 °F], 1013 mbar.



**WARNING!**

**IMPORTANT!**

An external fine filter must always be used at the gas inlet of the analyzer. Depending on the composition of the sample gas, it may be necessary to use a sample conditioning system.

Options	
Part No. 05A9005	Extra charge for one breathing and draining device for PMA50 EX enclosure, for sample gas pressures up to max. 1.5 bar abs. and non-corrosive gases
Part No. 05A9000	Purging the enclosure via 2 breathing and draining devices in the gas inlet and outlet, connection NPT 1/4" i, for sample gas pressures up to max. 1.5 bar abs. and/or corrosive gases, purge gas flow rate 10 to 60 NI/h, purge gas inlet pressure max. 1.1 bar abs.
Part No. 90A0009	Measuring cell type PMC-1LB, solvent-resistant
Part No. 90A0006	Measuring cell PMC-1G with glass solder. O-ring made of Chemraz®

Chemraz® is a registered trademark for perfluoroelastomer by Greene Tweed, USA.



PMA1000 V2.2 O<sub>2</sub> Analyzer

## PMA1000(L)V2.2 O<sub>2</sub> Analyzer

Oxygen Analyzer from the M&C premium series GENTWO® in a modular concept

### Special Features

- Visualization of measured values of one year directly on the analyzer
- Modular concept
- Multi-sensor capable
- Innovative operation via 7" touch color screen
- Pressure compensation 0.6 to 1.6 bar abs.
- Four O<sub>2</sub> measuring ranges: Two of those are user programmable
- Electrically isolated signal output 0-20 mA/4-20 mA
- Modbus TCP/IP and AK protocol TCP/IP
- Ethernet/USB interface
- Two user programmable operating parameter outputs
- Automated calibration with 24 V driver output (PMA1000 V2.2 only)

### Application

The oxygen analyzer PMA1000(L) V2.2, a device of the GENTWO® series, is suitable for the continuous measurement of the oxygen content in gases. Directly streaming the measurement cell with a small gas volume of just 2 ml [≈ 0.122 in<sup>3</sup>] provides a very fast response time of the analyzer.

The M&C oxygen analyzer can be used for non-flammable sample gases and setups in non-hazardous areas like combustion control, process optimization, inertization monitoring, fermentation processes, environment monitoring or for laboratory applications.

### Description

A modular concept and an innovative human machine interface (HMI) are outstanding features of the PMA1000. These enable an intuitive understanding of the operating concept and an adaptation to several applications.

It comes basically in a 19" built-in enclosure by using a FKM (Viton®) tubing. A wide-range power supply, a 7" colored touch screen and a thermostated paramagnetic transducer are included as well as the dedicated sensor electronics and signal output boards. In addition, a pressure sensor has been included for process pressure correction, a temperature monitor and a sample flow indicator.

The measured values are provided via a 0-20 mA/4-20 mA output signal. Further outputs for status alarm and for relay switching are available.

Two operating parameters, which drive a switching output each, can be programmed by the user.

The data logging functionality represents a special feature of the analyzer. The measured values, warning and alarm messages of an entire year can be stored in the analyzer's memory and displayed in a diagram chart precisely time-wise resolved. The setup of a second oxygen PMA transmitter is an option.

The PMA1000 V2.2 provides a state-of-the-art manual as well as automated calibration functionality for the zero point and span including outputs for controlling and switching the status alarm, a sample pump and four solenoid valves.

### Measuring principle of the M&C O<sub>2</sub> analyzers

The O<sub>2</sub> analyzer PMA1000(L)V2.2 of the GENTWO® series utilizes the paramagnetic dumb-bell principle of operation to measure the oxygen concentration. This physical measuring principle is characterized by its accuracy, absolute linearity and low-drift, long-term stable measurement in the range of 0 to 100 vol% oxygen without consuming sensor material or auxiliary materials. The paramagnetic function of the temperature-stabilized measuring cell uses the paramagnetic susceptibility of oxygen and is therefore very selective and is almost free of cross-sensitivity.

The analyzer has a long service life if used as intended, and if suitable gas sampling and conditioning components are provided.

# Gas connections and pin assignment diagram PMA1000 V2.2 and PMA1000L V2.2

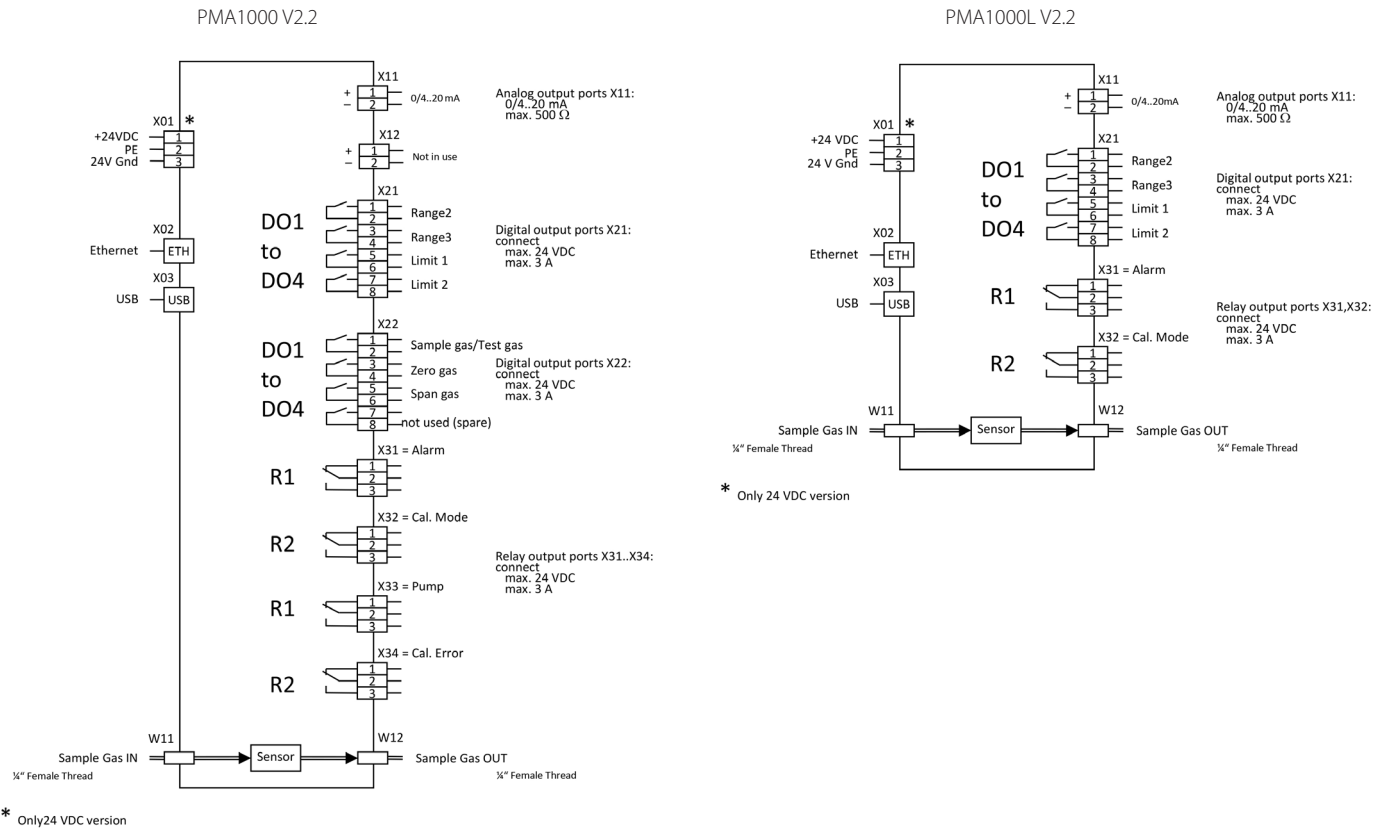

## Dimensions

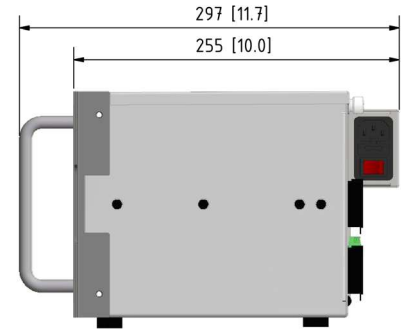
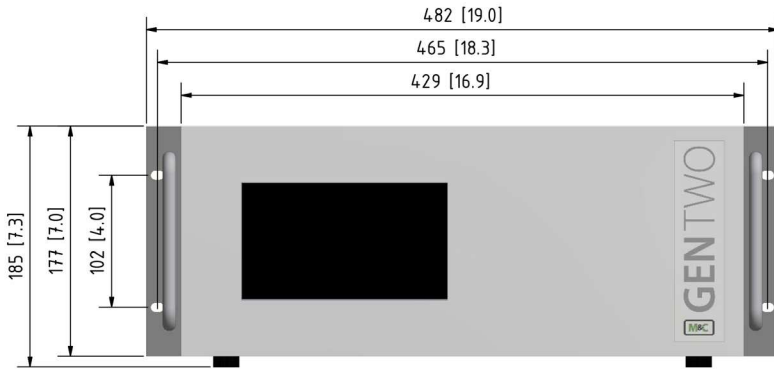

Short enclosure side view with power supply

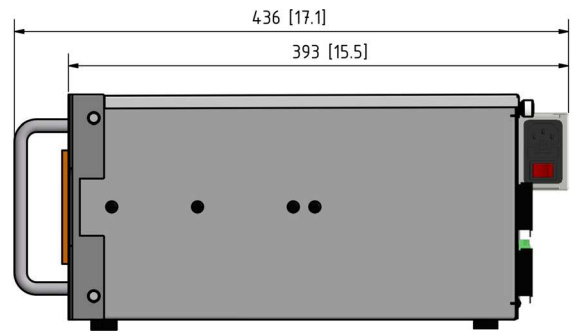

Long enclosure side view with power supply

Dimensions in mm [Inches]

## Technical Data

O <sub>2</sub> Analyzer - GENTWO series	PMA1000 V2.2	PMA1000L V2.2
Long enclosure Part No.	<b>08A2000</b>	<b>08A2005</b>
Short enclosure Part No.	<b>08A2010</b>	<b>08A2015</b>
Sample gas	O <sub>2</sub>	
Measuring ranges	4 linear measuring ranges, 2 of those freely selectable, lowest span 1 %, factory default 0-1, 0-10, 0-30 and 0-100 vol% O <sub>2</sub> , zero suppression applicable	
Limit of detection (LOD)**	0.02 vol%	
Response time* for 90 % FSD	< 3 seconds at 60 NI/h air	
Zero-point offset (drift)**	< 0.06 vol% O <sub>2</sub> in 72 hours	
Linearity error	< ±0.1 vol% O <sub>2</sub>	
Accuracy after calibration**	Deviation ±1 % of full scale or 0.02 vol% O <sub>2</sub> , whichever value is greater.	
Reproducibility**	< ±0.01 vol%	
Flow rate of sample gas	25 to 60 NI/h air	
Influence of sample gas flow	Variation in gas flow between 25 - 60 NI/h air will cause a deviation of < 0.1 vol% O <sub>2</sub>	
Sample gas inlet pressure	0.6 - 1.6 bar	
Sample gas outlet pressure	Recommendation: discharge freely into atmosphere (requires higher pressure at the analyzer inlet compared to the outlet)	
Influence of sample gas pressure	< 1 % of full scale within the range of 0.6 to 1.6 bar abs. with activated pressure compensation	
Sample gas temperature and characteristics	0 to 50 °C [32 to 122 °F]; dry, oil- and dust free gas, avoid temperature dropping below dew point	
O <sub>2</sub> transducer temperature	Fixed at 55 °C [131 °F]	
Ambient temperature	0 to 50 °C [32 to 122 °F], avoid temperature dropping below dew point	
Influence of ambient temperature	< 1 % of full scale	
Display	7" resistive touchscreen	
Output signals	Adjustable 0-20 mA / 4-20 mA, max. 500 Ohms burden, short-circuit proof, electrically isolated, Modbus TCP/IP, AK protocol TCP/IP	
Relay outputs	4 x relay output (1 x status, 1 x Cal-mode, 1 x pump control, 1 x Cal-error), contacts: 24 V DC / 3 A, 1 x change-over contact, potential-free	2 x relay output (1 x status, 1 x Cal-mode), contacts: 24 V DC / 3 A, 1 x change-over contact, potential-free
Digital outputs (DO)	8 x DO 24 V DC, max. 3 A (2 x operating parameters, 2 x measuring range feedback, 4 x valve control)	4 x DO 24 V DC, max. 3 A (2 x operating parameters, 2 x measuring range feedback)
AutoCal-Function	Yes	No
Interfaces	Ethernet / USB	
Communication protocol	Modbus TCP/IP, AK protocol TCP/IP	
Storage temperature	-20 to +60 °C [-4 to +140 °F], avoid temperature dropping below dew point	
Power supply	115 to 230 V AC, 50 to 60 Hz power supply or 24 V DC connector plug	
Power consumption	Max. 150 VA	Max. 100 VA
Wetted materials	Platinum, Epoxy resin, glass, FKM (Viton®), Stainless Steel 316Ti, PVDF, PPS	
Sample gas connection	Screw-on bulkhead fitting with 1/4" internal thread, PVDF	
Case protection	IP40, EN 60529	
Electrical standard	EN 61010	
Housing/front color	19 inch rack mounting (4RU)/white RAL 9003	
Maximum installation altitude	2000 m [≈ 6561.7 ft]	
Dimensions long enclosure (W x H x D)	Long enclosure with 230 V power supply (dimensions include front handles and power supply): 482 x 185 x 436 mm [≈ 19" x 7.3" x 17.1"] + approx. 60 mm [≈ 2.4"] connection depth	
Dimensions short enclosure (W x H x D)	Short enclosure with power supply (dimensions include front handles and power supply): 482 x 185 x 297 mm [≈ 19" x 7.3" x 11.7"] + approx. 60 mm [≈ 2.4"] connection depth	
Weight long enclosure	Approx.13 kg [≈ 29 lbs]	
Weight short enclosure	Approx.11 kg [≈ 24 lbs]	

\* Depends on sample gas input pressure, density and flow rate at the analyzer input.

\*\* At constant pressure, temperature and sample gas flow rate.

Viton® is a registered trademark for fluoropolymer elastomer by DuPont Performance Elastomers, USA.

Please note: NI/h and NI/min refer to the German standard DIN 1343 and are based on these standard conditions: 0 °C [32 °F], 1013 mbar.