

Gas Sample Probe Series SP[®]

SP2020-H/C/I/BB, SP2020-H/C/I/BB/F SP2020-H220/C/I/BB, SP2020-H220/C/I/BB/F

Instruction Manual
Version 1.00.02



Contents

1	General information	4
2	Declaration of conformity	4
3	Safety instructions	5
4	Warranty	5
5	Used terms and signal indications	6
6	Introduction	7
6.1	Serial numbers	7
7	Technical Data	8
8	Applications	8
9	Description	9
9.1	Probe Structure	10
10	Receipt of goods and storage	13
11	Preparation and Installation	13
12	Mounting	14
12.1	Pneumatic connexions.....	15
12.2	New filter housing lid from Serial Nos. 10283	16
13	Electrical connections	17
13.1	Standard Version with Internal Capillary Tube Thermostat	18
13.2	Version with External Temperature Control	19
14	Starting	19
14.1	Calibration gas feed and backflushing	20
15	Maintenance	21
16	Switching Off	21
17	Spare parts list	22
18	Appendix	23

List of illustrations

Figure 1	Probe mounting with adapter flange or R2" adapter.....	14
Figure 2	Connexions SP2020-H/C/I/BB and SP2020-H/C/I/BB/F.....	15
Figure 3	New filter housing lid ex serial number 10283.....	16
Figure 4	Removing the new filter housing lid	17
Figure 5	Electrical connection at the capillary tube thermostat.....	18
Figure 6	Electrical connexions at the electronic controller 70304G	19
Figure 7	Electrical connexions for SP2020-H.. with thermostate controller	24
Figure 8	Electrical connexions for SP2020-H.. with electronic controller 70304G	25
Figure 9	Possible filter elements.....	26
Figure 10	Sample tubes and pre filter.....	27
Figure 11	High temperature sample tube out of aluminium oxide	28
Figure 12	Heated sample tubes SP30.....	29
Figure 13	Solenoid valve unit 2	30



Dear customer,

Thank you for buying our product. In this instruction manual you will find all necessary information about this M&C product. The information in the instruction manual is fast and easy to find, so you can start using your M&C product right after you have read the manual.

If you have any question regarding the product or the application, please don't hesitate to contact M&C or your M&C authorized distributor. You will find all the addresses in the appendix of this manual.

For additional information about our products and our company, please go to M&C's website www.mc-techgroup.com. There you will find the data sheets and manuals of all our products in German and English.

This Operating Manual does not claim completeness and may be subject to technical modifications.

© 09/2019 **M&C TechGroup** Germany GmbH. Reproduction of this document or its content is not allowed without permission from **M&C**.

SP® is a registered trade mark.

Version: 1.00.02

Head Office

M&C TechGroup Germany GmbH ♦ Rehhecke 79 ♦ 40885 Ratingen ♦ Germany

Telephone: 02102 / 935 - 0

Fax: 02102 / 935 - 111

E - mail: info@mc-techgroup.com

www.mc-techgroup.com

1 GENERAL INFORMATION

The product described in this manual has been built and tested in our production facility.

All M&C products are packed to be shipped safely. To ensure the safe operation and to maintain the safe condition, all instructions and regulations stated in this manual need to be followed. This manual includes all information regarding proper transportation, storage, installation, operation and maintenance of this product by qualified personnel.

Follow all instructions and warnings closely.

Read this manual carefully before commissioning and operating the device. If you have any questions regarding the product or the application, please don't hesitate to contact M&C or your M&C authorized distributor.

2 DECLARATION OF CONFORMITY



The product described in this operating manual complies with the following EU directives:

EMV-Instruction

The requirements of the EU directive 2014/30/EU "Electromagnetic compatibility" are met.

Low Voltage Directive

The requirement of the EU directive 2014/35/EU "Low Voltage Directive" are met.

The compliance with this EU directive has been examined according to DIN EN 61010.

Declaration of conformity

The EU Declaration of conformity can be downloaded from the **M&C** homepage or directly requested from **M&C**.

3 SAFETY INSTRUCTIONS

Please take care of the following basic safety procedures when mounting, starting up or operating this equipment:

Read this operating manual before starting up and use of the equipment. The information and warnings given in this operating manual must be heeded.

Any work on electrical equipment is only to be carried out by trained specialists as per the regulations currently in force.

Attention must be paid to the requirements of VDE 0100 (IEC 364) when setting high-power electrical units with nominal voltages of up to 1000 V, together with the associated standards and stipulations.

Check the details on the type plate to ensure that the equipment is connected to the correct mains voltage.

Protection against touching dangerously high electrical voltages:

Before opening the equipment, it must be switched off and hold no voltages. This also applies to any external control circuits that are connected.

The device is only to be used within the permitted range of temperatures and pressures.

Check that the location is weather-protected. It should not be subject to either direct rain or moisture.

The equipment must not be used in hazardous areas.

Installation, maintenance, monitoring and any repairs may only be done by authorized personnel with respect to the relevant stipulations.

4 WARRANTY

In case of a device failure, please contact immediately M&C or your M&C authorized distributor.

We have a warranty period of 12 months from the delivery date. The warranty covers only appropriately used products and does not cover the consumable parts. Please find the complete warranty conditions in our terms and conditions.

The warranty includes a free-of-charge repair in our production facility or the free replacement of the device. If you return a device to M&C, please be sure that it is properly packaged and shipped with protective packaging. The repaired or replaced device will be shipped free of delivery charges to the point of use.

5 USED TERMS AND SIGNAL INDICATIONS



DANGER!

This means that death, severe physical injuries and/or important material damages **will occur** in case the respective safety measures are not fulfilled.



WARNING!

This means that death, severe physical injuries and/or important material damages **may occur** in case the respective safety measures are not fulfilled.



CARE!

This means that minor physical injuries **may occur** in case the respective safety measures are not fulfilled.

CARE!

Without the warning triangle means that a material damage may occur in case the respective safety measures are not met.

ATTENTION!

This means that an unintentional situation or an unintentional status may occur in case the respective note is not respected.



NOTE!

These are important information about the product or parts of the operating manual which require user's attention.

SKILLED STAFF

These are persons with necessary qualification who are familiar with installation, use and maintenance of the product.



High voltages!

Protect yourself and others against damages which might be caused by high voltages.



Corrosive!

These substances destroy living tissue and equipment upon contact.

Do not breathe vapors; avoid contact with skin and eyes.



Hot surface!

Contact may cause burn! Do not touch!



Wear protective gloves!

Working with chemicals, sharpe objects or extremely high temperatures requires wearing protective gloves.



Wear safety glasses!

Protect your eyes while working with chemicals or sharpe objects. Wear safety glasses to avoid getting something in your eyes.



Wear protective clothes!
Working with chemicals, sharpe objects or extremely high temperatures requires wearing protective clothes.

6 INTRODUCTION

M&C gas sample probes provide direct insitu ultra-fine filtration during continuous gas sampling for analytic measurements. In this way, part of the necessary maintenance work for a system is concentrated on a single point. This filter technology has the major advantage that dust mixtures consisting of ultra-fine and coarse dusts can be optimally retained with the least possible maintenance work.

Optimal adaptation of the sample probe to processing conditions and to measurement work is a necessary condition for a measurement system to work smoothly. Basically, the gas sample should be kept to a necessary minimum. This is made possible thanks to optimised downstream gas processing using **M&C** components. Only in this way is it possible to reduce maintenance to a minimum while ensuring maximum availability.

6.1 SERIAL NUMBERS

The nameplates bearing the serial number are located on the side of the electrical connection box.



NOTE!

Always quote the device's serial number when making enquiries and ordering replacement parts.

7 TECHNICAL DATA

Mains supply	115 V 60 Hz 800 W
Flange	SS316Ti, 3" 150 lbs
Electrical connection	Terminals; max 4 mm ² , 2 x PG13,5 cable gland
Protective type	IP54 (EN 60529)*
Ambient temperature	Thermostat: -20 to 60 °C [-4 to 140 °F] PT100, thermocouple: -20 to 80°C [-4 to 176 °F]
Operating temperature	SP2020-H... : 0 to 180°C [32 to 356 °F] SP2020-H220... : 0 to 220°C [32 to 428 °F]
Ready for operation	After 2 hours
Temperature status alarm point	±30 °C [±54 °F] to T _{Set} *
Alarm contact rating	250 V 3 A AC, 0.25 A DC
Connection sample outlet	1/4"-NPT i., for max. 10 mm tube connectors
Connection backflush	Tube fitting 3/8" O.D.
Connection calibration gas	Tube fitting 1/4" O.D.
Filter chamber volume	120 ml
Sample pressure	0.4 to 6 bar abs.
Material of sample conducting parts	SS316Ti, Viton* alternative = SS316Ti, PTFE

* = Standard

Differential pressure and T ₉₀ -time at different flow rates:						
ΔP and T ₉₀ at flow of	100	200	500	1000	1500	Nl/h
ΔP with new filter element S-2K 150 or F-0,1GF150:	0.007	0.011	0.020	0.035	0.04	bar
T ₉₀ -time without sample tube/pre filter:	6.0	3.5	1.0	<0.5	<0.5	sec.

8 APPLICATIONS

The **SP2020...** gas sample probes are used for continuous extraction of gases from dust loaded, high-temperature or humid processes.

A host of different variations in sampling technology as well as some built-in accessories offer a wide range of possible applications for nearly all problems encountered in taking gas samples from processes with high dust content where an effective backflush is necessary. Sampling from processes up to a maximum of 1900 °C [3452 °F] are possible with this probe.

9 DESCRIPTION

The sample probes are designed for easy installation, reliable and flexible operation and trouble-free maintenance.

Filter elements can be changed without the need for tools and without disconnecting the sample line, the filter chamber can be cleaned easily, the probe tube can be cleaned without removing the probe: these are just a few of the many advantages offered by this probe.

The filter element, which has a large surface, is located in a stainless steel filter housing.

The following filter elements are available:

Filter element type S-2K-150*	2 micron	Ceramic
Filter element type S-3G-150	3 micron	Glass
Filter element type S-3SS-150	3 micron	Stainless steel 316
Filter element type S-0,1GF-150	0.1 micron	Glass fiber

The following sealing materials are used:

Viton*	Standard	Max. 180 °C [356 °F]
PTFE	Type /7aT	Max. 180 °C [356 °F]

The following types of filter heating and adjustment are possible:

Electrical heating and adjustment with internal capillary tube thermostat*	Type /H(220)*
Electrical heating and adjustment with external electronic controller	Type /PT100
Electrical heating and adjustment with external electronic controller	Type /Fe-CuNi

*Standard

9.1 PROBE STRUCTURE

The filter housing with its all-round heating element forms a unit with the standard mounting flange DN65 PN6 and the laterally mounted electrical connection box.

The heat-insulated shield is mounted on the stainless steel angle sheet which is mounted on the mounting flange. It is secured with 2 pressure clamps. The cover ensures a uniform distribution of heat over the probe heater and at the same time serves as protection against weather and accidental contact.

The connecting clamp for attaching heated **M&C** sample lines with external dimensions of between 40 mm and 50 mm is located at the aperture on the underside of the angle sheet, which is closed with a silicon lid. The clamp is mounted on an adjustable mounting bracket which allows adjustment for various sample line diameters.

The standard probe's sample gas outlet connection has a ¼" NPT internal thread to which the customer must connect a suitable size of temperature resistant and threaded connector to connect the sample line in a gas tight manner. These connectors can be supplied by **M&C**.

After the threaded pipe connector and sample line have been mounted, the sample gas outlet connection is enclosed in special heat-conducting jaws in order to avoid temperature failures in the critical connection areas. The size of the heat-conducting jaws allows connection joints up to an external pipe dimension of 10 mm.

In the standard version, temperature control is ensured by way of the capillary tube thermostat which is built into the connection box and which has a regulation range between 0°C to 180 °C [32 to 356 °F]. Rated values can be set to a maximum 180 °C [356 °F]. The temperature has an excess temperature limiter which permanently switches off the heating if the set temperature is exceeded by 30 °C [$\Delta T = 54$ °F]. The heating can be switched back on again by pressing the **RESET button** which is located below the aperture in the thermostats mounting and which is marked **RESET**.

The thermostat has a temperature failure alarm which activates a contact if the temperature falls 30 °C [$\Delta T = 54$ °F] below the set temperature. This status alarm is located on the terminal strip as a potential-free switch over contact.

If temperature control is to be achieved using external electronic equipment, a PT100 (a max. of two can be built in) or an Fe-CuNi thermoelement is provided as a temperature sensor.

For test gas feeding and back purging, check valves are integrated in the gas sample probe. To prevent a flow of test gas back to the process while test gas feeding, a pneumatic isolation valve is mounted in the sample gas outlet.

To prevent the analyzer from a pressure surge while back flushing the pneumatic isolation valve has to be used as well.

The gas sample probe **SP2020-H/C//BB** is designed for back flushing via the filter chamber. The design of the **SP2020-H/C//BB/F** allows back flushing via the filter element (see Fig.2).

Depending on the process gas temperature and composition, probe tubes made of different materials are used with 3/4" connections:

Material	Type	Process temperature	max. length	Pipe (nipple) o.d.
Stainless steel 316	SS	up to max. 600 °C [1112 °F]	2.5 m	25 (37) mm ø
Titan	Ti	up to max. 400 °C [752 °F]	2.5 m *	25 (37) mm ø
Hastelloy	Ha	up to max. 900 °C [1652 °F]	2.5 m *	25 (37) mm ø
Incolloy 956	In	up to max. 1200 °C [2192 °F]	2.0 m *	25 (37) mm ø
Kanthal	Ka	up to max. 1300 °C [2372 °F]	2.5 m *	25 (37) mm ø
Alu. oxide	AO	up to max. 1800 °C [3267 °F]	1.5 m *	25 (55) mm ø
PVDF	PV	up to max. 90 °C [194 °F]	1.5 m *	25 (37) mm ø
PTFE	T	up to max. 160 °C [320 °F]	0.5 m	33 mm ø

1 m standard *

Depending on the process gas temperature and composition or critical set up situations, heated probe elements made of stainless steel with flange connection DN65 PN6 are used:

Type	Process temperature	Max. length	Pipe o.d.
SP30H1, heating max. 320 °C [608 °F]	up to max. 550 °C [1022 °F]	2.0 m *	40 mm ø
SP30H2, heating max. 200 °C [392 °F]	up to max. 200 °C [392 °F]	2.0 m *	40 mm ø
SP35H, heating max. 320 °C [608 °F]	up to max. 550 °C [1022 °F]	0.175 m	40 mm ø

1 m Standard *

In case of higher dust loadings of the process gas, by all means we recommend using a prefilter in order to prolong service life. This can be supplied with or without dead volume displacer depending on the response times required. These filters can be screwed directly into the probe flange or via extension tubes fitted with volume displacers (see Fig.10).

We recommend the following prefilters with 3/4" connection:

Dust loading	Prefilter Type	Process Temperature	Prefilter o.d.
< 2 g/m ³	no filter, only probe tube	see above	
2-10 g/m ³	/V20, /V20-0	up to max. 600 °C [1112 °F]	ø 46 mm
	/V20-3, /V20-4	up to max. 600 °C [1112 °F]	ø 31 mm
	/V20/HC, /V20-0/HC	up to max. 900 °C [1652 °F]	ø 46 mm
	/V20-5	up to max. 500 °C [932 °F]	ø 50 mm
	with deflector for high flow speed		60 mm ø
> 10 g/m ³	/V20-1, /V20-2	up to max. 600 °C [1112 °F]	ø 60mm
	/V20-1/HC, /V20-2/HC	up to max. 900 °C [1652 °F]	ø 60mm
	/V20-T	up to max. 200 °C [392 °F]	ø 65mm
	/V20-6	up to max. 500 °C [932 °F]	ø 60mm
	with deflector for high flow speed		65mm ø
	/V12-1	up to max. 600 °C [1112 °F]	ø 40 mm
	/V12-2, /V12-3	up to max. 600 °C [1112 °F]	ø 60 mm
	/V12-1/SS	up to max. 600 °C [1112 °F]	ø 40 mm
	/V12-2/SS, /V12-3/SS	up to max. 600 °C [1112 °F]	ø 60 mm
	/V12-1/IC	up to max. 1000 °C [1832 °F]	ø 40 mm
	/V12-2/IC, /V12-3/IC	up to max. 1000 °C [1832 °F]	ø 60 mm

10 RECEIPT OF GOODS AND STORAGE

- The gas sample probe and any special accessories should be removed carefully from the packaging and checked immediately for completeness against the delivery note.
- Check the goods for any damage incurred during transport and if necessary inform your transport insurer of any damage.

The gas sample probe is normally delivered in two packaging units:

1. The gas sample probe with the screws, nuts and flange seal required for mounting.
2. Sample tube or prefilter, if applicable with extension tube.



NOTE!

The equipment should be stored in a protected, frost-free room!

11 PREPARATION AND INSTALLATION

Select the optimal sampling point in accordance with the generally applicable guidelines or consult the competent persons.

Locate the sampling point in such a way that there is adequate space for inserting and removing the probe and pay attention to the insertion length of the probe tube.

Make certain that the probe is easily accessible so that you can carry out any subsequent maintenance work without trouble.

Locate the probe connections in such a way that the connections' temperature is always above the acid dew point in order to avoid corrosion and blockage problems. If this is not possible, a heated **SP35/SP30** probe tube is recommended for cold connections.

If the ambient temperature in the area of the connections is $> 80\text{ }^{\circ}\text{C}$ [$176\text{ }^{\circ}\text{F}$] as a result of radiated heat, then a radiated-heat deflector must be mounted to protect the probe.

The connection's mounting flange connection should comply with DN65 PN6. If other connection sizes are required, a special adapter flange **/S010** can be supplied as an option.

Instead of flange connection mounting, the probe can also be mounted using an R2" adapter **/S01** on a corresponding threaded sleeve connection. This adapter can be supplied.

The necessary minimum flange size and the minimum connection diameter depends on the diameter of the probe tube or prefilter used.

Before mounting, the probe must be adjusted to the existing operating conditions.

The existing operational parameters are to be checked accordingly prior to commencing mounting work.

Under / over pressure situation	mbar	bar	
Process temperature	$^{\circ}\text{C}$	$^{\circ}\text{C}$	
	Min.	Max.	
Dust loading	g/m^3		
Dust composition - grain size	μm		
Gas composition	corrosive	toxic	explosive
Which parameters should be measured, e.g. O_2 , CO , SO_2 , NO_x , ...	Vol. %	mg/Nm^3	ppm
Required amount of gas	l/h	l/h	
	Min.	Max.	
Necessary T_{90} -time	sec.		

12 MOUNTING

M&C **SP2020**.. probes are designed for stationary use and if properly selected and mounted a long service life and minimum maintenance are guaranteed.

- Remove the probe's protection shield after opening the two clamping devices.
- Turn the U-bolt at the front end of the filter receptacle several times to the left until the retaining bolt can also be turned sideways to the left.
- Remove the filter receptacle from the probe and check whether the filter element is screwed on tightly.
- Then replace the filter receptacle, place the retaining bolt in its original position and tighten the U-bolt.
- Remove the heat-conducting jaws at the sample gas outlet after loosening the knurled-head screw.
- In order to connect the sample line, screw in a suitably sized threaded connector with a ¼"-NPT connecting thread using PTFE sealing tape.



NOTE!

Make sure that the connection is leakproof!

- Screw either the probe tube or prefilter supplied directly or using an extension tube into the ¾" inner thread in the flange of the probe with the ¾" flat gasket and tighten.
- If the heated probe tube type **SP30/35** or the ceramic prefilter type **V12** is used, then the probe is to be screwed to their flange (with welded threaded bolt). First insert the flange seal between the two flanges.
- If the probe connection does not correspond to the standard flange connection, then the optionally supplied adapter flange should be mounted to the probe in the same way.

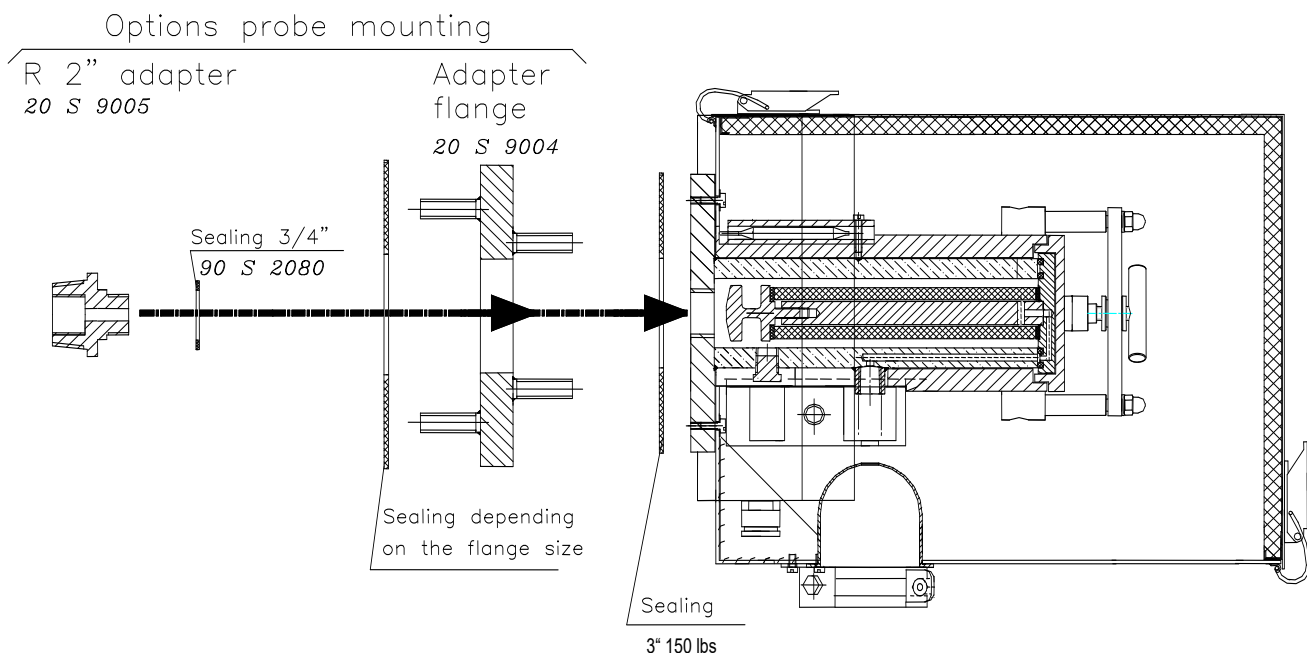

Figure 1 Probe mounting with adapter flange or R2" adapter

- Now insert the process-internal probe section of the complete probe unit into the probe connection, but first attach the flange seal to the probe connection and screw using the screws and nuts supplied.

**NOTE!**

A preferred mounting position is to have the probe with its sample gas outlet pointing downwards, although this is not absolutely necessary for perfect functioning. An advantage as well is mounting the probe with an angle (10°) downwards.

12.1 PNEUMATIC CONNEXIONS

- Remove the upper part of the sample line's mounting bracket and insert the sample line through the silicon lid into the threaded pipe joint and connect it.
- The temperature-resistant, stainless steel connectors supplied by **M&C** have a double ferrule system to ensure reliable sealing. After tightening the nuts of these connectors by hand, they should then be tightened exactly $1\frac{1}{4}$ of a turn using a flat spanner and are then properly mounted.
- If a PTFE tube is used as sample line, an insert must under all circumstances be inserted in the end of the tube in order to prevent the tube being pressed together.
- Screw on the upper part of the mounting bracket.
- In the case of larger sample line diameters, it may be necessary for the central mounting of the sample line to loosen the two screws and move the small mounting bracket of the mounting bracket and then re-tighten them. Now place the heat conducting jaws around the sample gas connection in the retaining slot and fix with the knurled nuts.
- Connect a tube $\frac{1}{4}$ " at the check valve /C for calibration gas feeding and a tube $\frac{3}{8}$ " at the backflush valve /BB or /BBF
- Screw a suitable stainless steel connector into the $\frac{1}{8}$ " NPT thread of the isolation valve /I with pneumatic drive. The control line for operating the pneumatic drive has to be connected to this stainless steel connector.
- Now replace the protection shield and fasten using the pressure clamps.

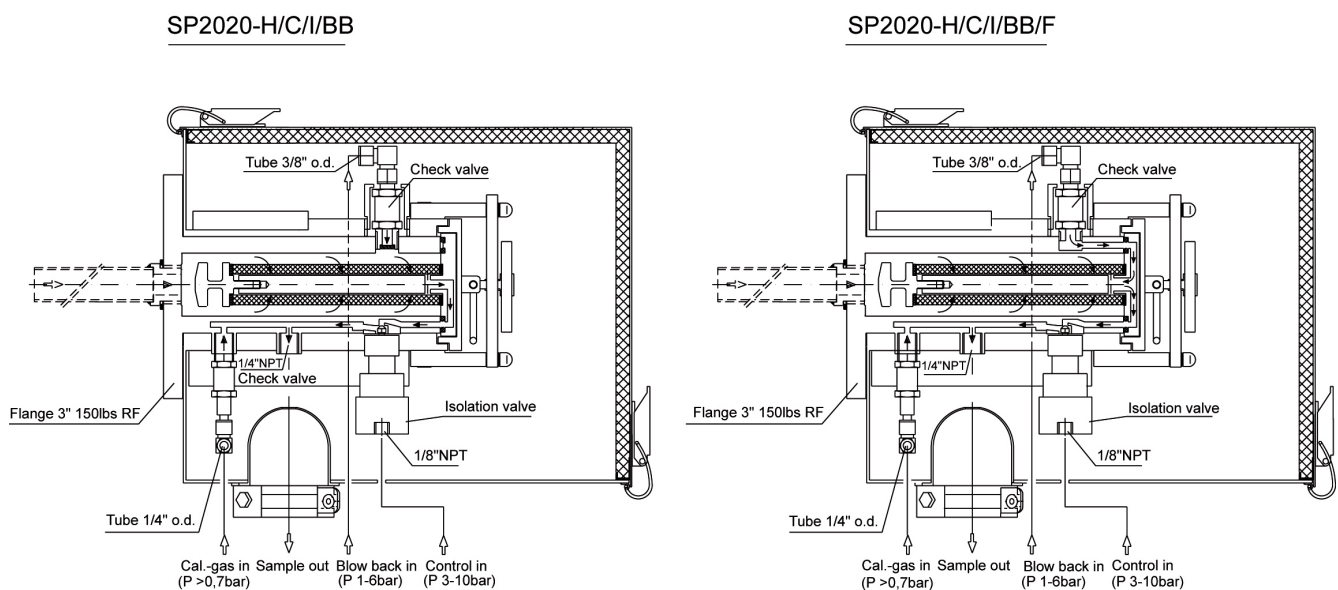

Figure 2 Connexions SP2020-H/C//BB and SP2020-H/C//BB/F

12.2 NEW FILTER HOUSING LID FROM SERIAL NOS. 10283

The sample probe series SP2000 will be delivered, starting with the serial number 10283, with a new filter housing lid lock, to make filter replacement easier.

The modification consists of a toggle screw „A“, which allows to fasten the filter housing lid by turning the screw clockwise and lifting up the lid by turning it anti-clockwise. After turning the clamp „B“ to the left hand side, the filter housing lid can be removed.

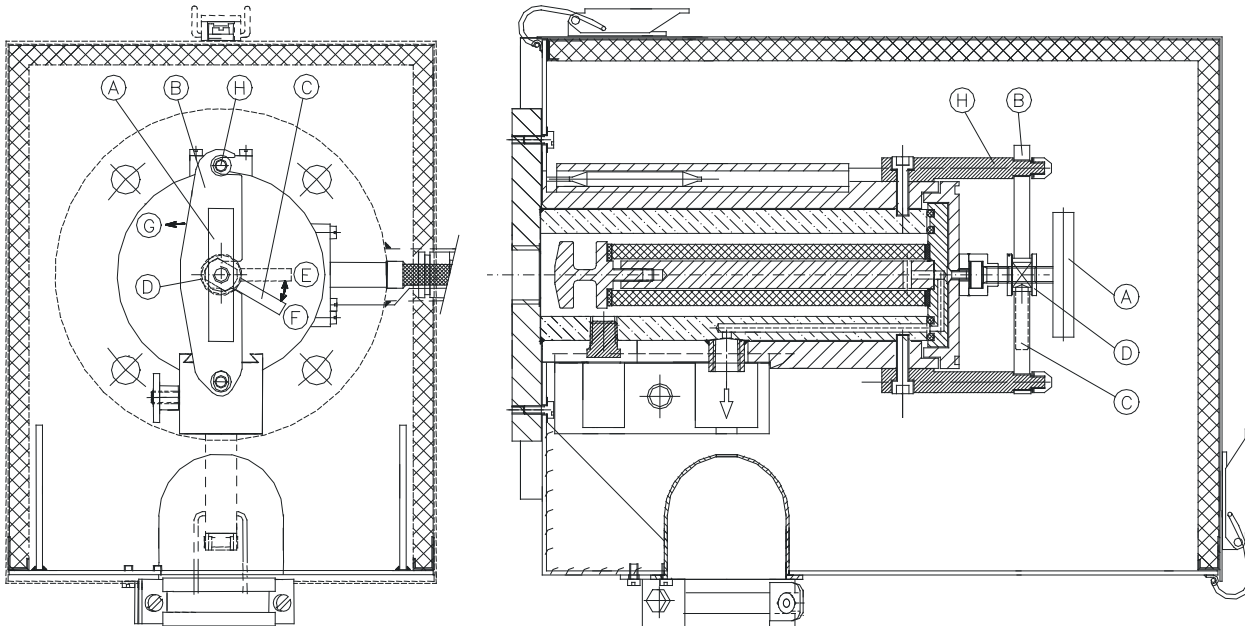

Figure 3 New filter housing lid ex serial number 10283

The following steps are recommended removing the filter housing lid:

- Turn toggle screw „A“ approx. 1 turn counter-clockwise, that the filter housing lid will lift up;
- Turn handle „C“ in position „E“;
- Turn clamp „B“ counter-clockwise in direction „G“;
- Take toggle screw „A“ and pull out the filter housing lid;
- Change filter element and possibly the lids;
- Push in the filter housing lid into the filter area;
- Turn clamp „B“ clockwise and turn with the handle „C“ the ring screw „D“ in position „E“, that the clamp „B“ will latch into the ring screw „D“ and the threaded bolt „H“. It could be necessary to move the filter housing lid a little bit forward and backward;
- Turn handle „C“ in position „F“ and fasten the filter housing lid by turning the toggle screw „A“ clockwise by hand.

The following pictures should explain the above mentioned steps.

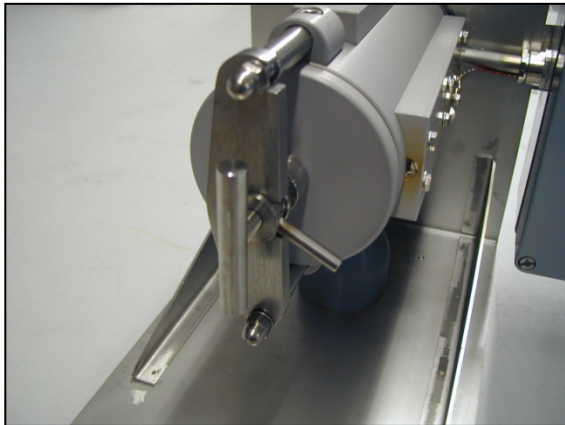
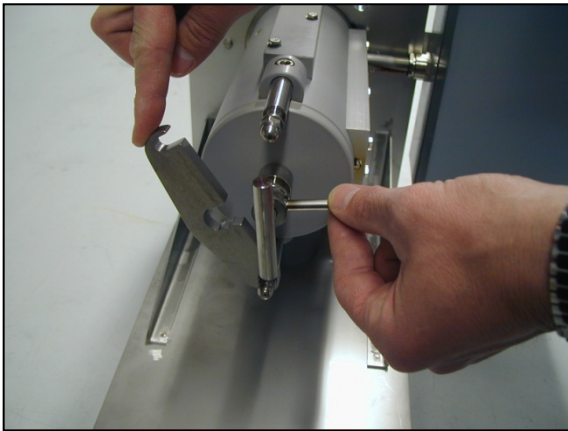

Figure 4 Removing the new filter housing lid

The new locking is available as a complete set for sample probes older than serial number 10283 (part no.: 93S0081).

13 ELECTRICAL CONNECTIONS



WARNING!

When connecting the equipment, please ensure that the supply voltage is identical with the information provided on the model type plate.



WARNING!

Use always the low temperature alarm. In case of an alarm the flow can be stopped and the components downstream the probe are safe for damage.



Attention must be paid to the requirements of IEC 364 (DIN VDE 0100) when setting high-power electrical units with nominal voltages of up to 1000 V, together with the associated standards and stipulations.

In any case we recommend the use of temperature resistant cable !

A main switch and matching fuse must be provided externally!

The main circuit must be equipped with a fuse corresponding to the nominal current (over current protection); for electrical details see technical data.

13.1 STANDARD VERSION WITH INTERNAL CAPILLARY TUBE THERMOSTAT

- Remove the lid of the connection box. The electrical connection layout is located in the lid.
- Insert the mains cable (min. 3 x 1.5 mm²) through the treaded cable gland and connect to the appropriate terminals.
- Insert the signal cable through the treaded cable connection and connect to the appropriate terminals.
- Screw lid back on.

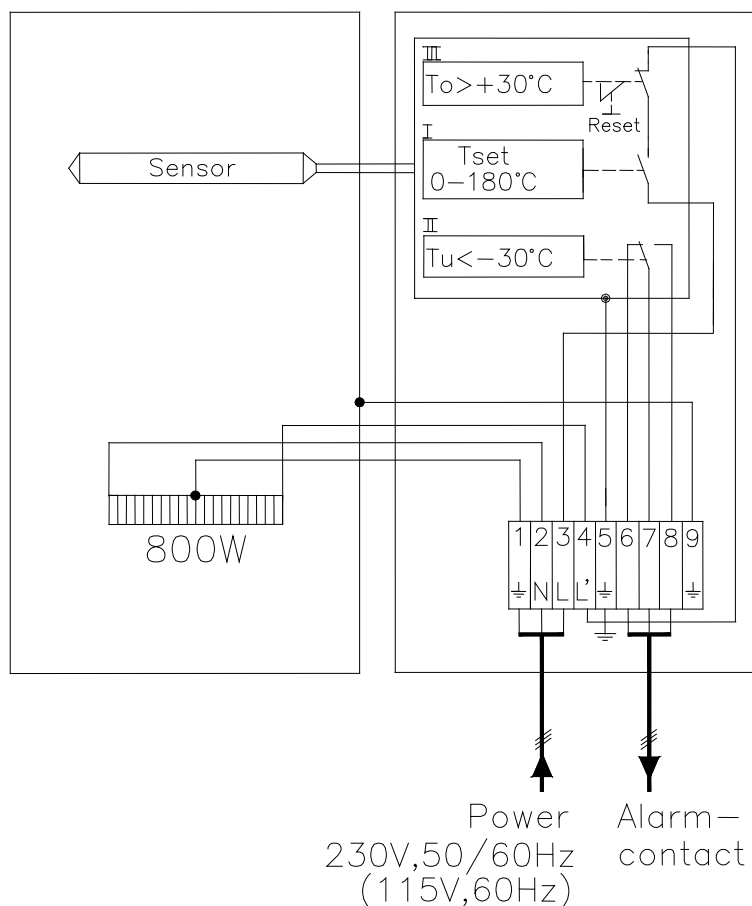

Figure 5 Electrical connection at the capillary tube thermostat

13.2 VERSION WITH EXTERNAL TEMPERATURE CONTROL

- Remove the lid of the connection box. The electrical connection layout is located in the lid.
- Insert the mains cable coming from the external temperature controller (min. 3 x 1.5 mm²) through the threaded cable gland and connect to the appropriate terminals.
- Insert the temperature sensor cable through the threaded cable gland and connect to the appropriate terminals.
- Screw lid back on.

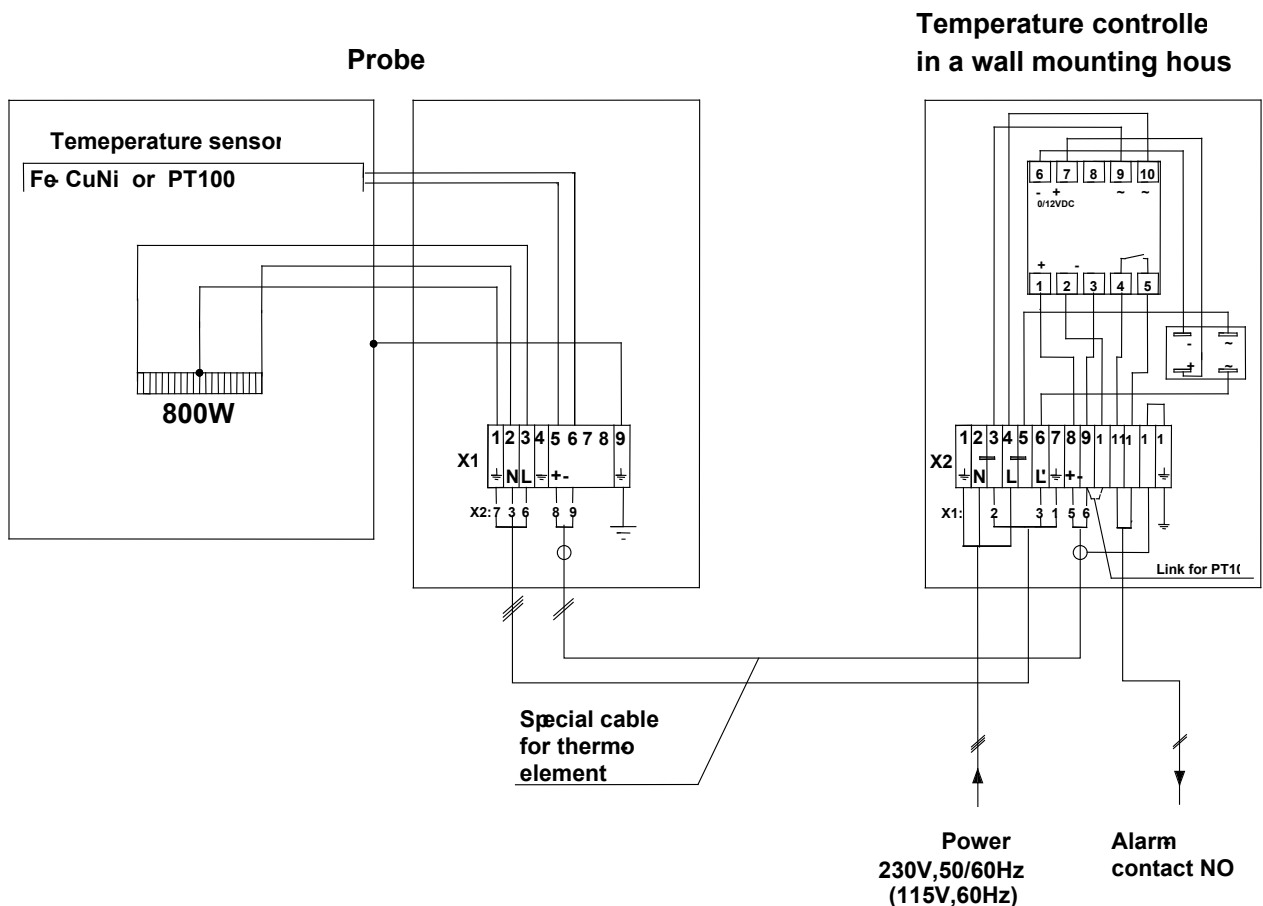

Figure 6 Electrical connexions at the electronic controller 70304G

14 STARTING

- Before starting up check whether the mains power supply voltage corresponds with the information stated on the probe's nameplate.
- Check the rated value setting on the built-in thermostat or on the external controller.
- Switch on mains power supply. The total heating-up time is approximately 2 hours. After about 1 hour the probe is already sufficiently heated for the temperature to have exceeded the temperature failure alarm value (30 °C [$\Delta T = 54$ °F] below rated value), but it still takes about another hour until operating temperature is reached.
- The sample gas can now be extracted via the probe after this minimum heating-up time of 2 hours.

**NOTE!**

If the rated value temperature needs to be lowered more than 30°C [$\Delta T = 54$ °F] in one step during operation, the thermostat's excess temperature switch-off is triggered!

**WARNING!**

Be careful when you get in contact with the probe's surface during operation. The high surface temperatures may cause burnings. Protective gloves are to be worn and any unauthorized access to the probe must be made impossible !



14.1 CALIBRATION GAS FEED AND BACKFLUSHING

In order to backflush the probe tube or the prefilter, flush gas is fed via the backflush valve. The downstream system has to be disconnected with the isolation valve from the probe before back flushing in order to avoid pressure shocks on the system. The check valve's opening pressure is 0.7 bar. To drive the isolation valve a pressure of 3 to 10 bar is necessary.

**NOTE!**

In order to prevent the probe's interior from cooling down, back-flushing should as far as possible only be carried out for a short time (< 1 s).

The analysis system remains closed while calibration gas is being fed in. The amount of calibration gas should be at least 25 % greater than the amount of sample gas drawn into the analysis system in order to avoid mixing with the sample gas. This type of calibration gas feeding is not to be used in the case of processes with over pressure. A built-in ball valve in the probe entrance is recommended here.

Basically, a smaller amount of calibration gas is needed in probes with a built-in ball valve as the probe is separated from the system on activating the ball valve and thus there is no danger of mixing with the process gas. In order to close the probe the control grip is to be turned by hand to the right until it reaches the stop.

**NOTE!**

In the case of low pressure care should be taken that no infiltrated air is drawn in via the unclosed check valve from 300 mbar upwards.

15 MAINTENANCE

The safety instructions specific to the plant and process are to be consulted prior to any maintenance work! It is difficult to give any recommendations as to a particular maintenance cycle. Depending on your process conditions, a meaningful maintenance cycle must be elaborated for the specific application.

An indication that probe-maintenance may be necessary could be shown by a constant decline in the amount of sample gas in the analysis system.

Probe maintenance is restricted essentially to replacing filter elements and checking seals.



WARNING!



**Aggressive condensate is possible.
Wear protective glasses and proper protective clothing!
High surface temperatures may cause serious burns!
Wear protective gloves!
Prevent the probe of unauthorized access!**



- Changing the filter element see chapter 12.2
- Additionally check O-rings in the lid (PTFE rings for **17aT**) and change if necessary.
- Clean filter chamber.
- It is now also possible to rod through the probe tube in order to remove deposits. Take care to avoid breakages when handling probe tubes made of alu-oxide.



NOTE!

In order to change prefilters, the entire probe unit must be removed from the process. The prefilters can be cleaned to an extent depending on the manner of soiling mechanically or in a ultra sonic bath and can used again.



WARNING!



**Prior carrying out maintenance work on electrical parts, mains voltage should be disconnected from all poles!
This also applies to any external control circuits which may be connected.**

16 SWITCHING OFF

Before switching off, i.e. switching off the heating, the probe be flushed with inert gas or air in order to avoid condensation of aggressive components from the process gas.

17 SPARE PARTS LIST

Wear, tear and replacement part requirements depend on specific operating conditions. The recommended quantities are based on experience and they are not binding.

Gas sample probe SP2020-H..					
(C) Consumable parts					
(R) Recommended spare parts					
(S) Spare parts					
		Recommended quantity being in operation [years]			
Part No.	Indication	C/R/S	1	2	3
90S0020	Filter element S-2K150 , ceramic, 2 µm, 150 mm	C	6	12	18
90F0125	Filter element F-0,1GF150 , glass fiber, 0.1 µm, 150 mm	C	6	12	18
93S0045	Gasket (30) for filter element. Material: Viton.	R	4	8	12
93S0051	Adaptor for probe filter element F-0,1GF. Material: PTFE	R	4	8	12
93S0020	O-ring (39) for lid. Material : Viton	R	2	4	8
93S0025	O-Ring (55) for lid. Material : Viton	R	2	4	8
93S0035	Sealing spiral o-ring (39) for lid SP2000/7aT Material : PTFE	R	1	2	3
93S0040	Sealing spiral o-ring (55) for lid SP2000/7aT Material : PTFE	R	1	2	3
90S2080	Gasket 3/4" (blue), max. 600 °C [1112 °F] for sample tube. Material Novapress	R	1	2	3
90S2077	Flange gasket DN65 PN6 (67 mm i.) Material : Novapress	R	1	1	1
90S2075	Flange gasket set DN65 PN6 B, consisting of gasket (67) and a set of screws 12 x 60.	S	1	1	1
93S0010	Thermostat (0 to 180 °C [32 to 356 °F]), with over-temperature limiter and low-temperature alarm for probe series SP.	R	-	-	1
93S0015	Heating cartridge 230 V AC/800 W, length 160 mm	R	-	-	1
93S0017	Heating cartridge 115 V AC/800 W, length 160 mm	R	-	-	1
93S0059	PT100 sensor	R	-	-	1
93S0060	Spare thermoelement Fe-CuNi with clamping ring and screw	R	-	-	1
93S0061	Spare thermoelement Ni-CrNi with clamping ring and screw	R	-	-	1

18 APPENDIX

- Electrical plans
- Filter elements – spare parts
- Sample tubes and pre filters
- Solenoid unit 2



More product documentation is available on our Internet catalogue:
www.mc-techgroup.com

- Sample tubes series **SP**
Document: **2.14**
- Prefilter series **SP**
Document: **2.17**

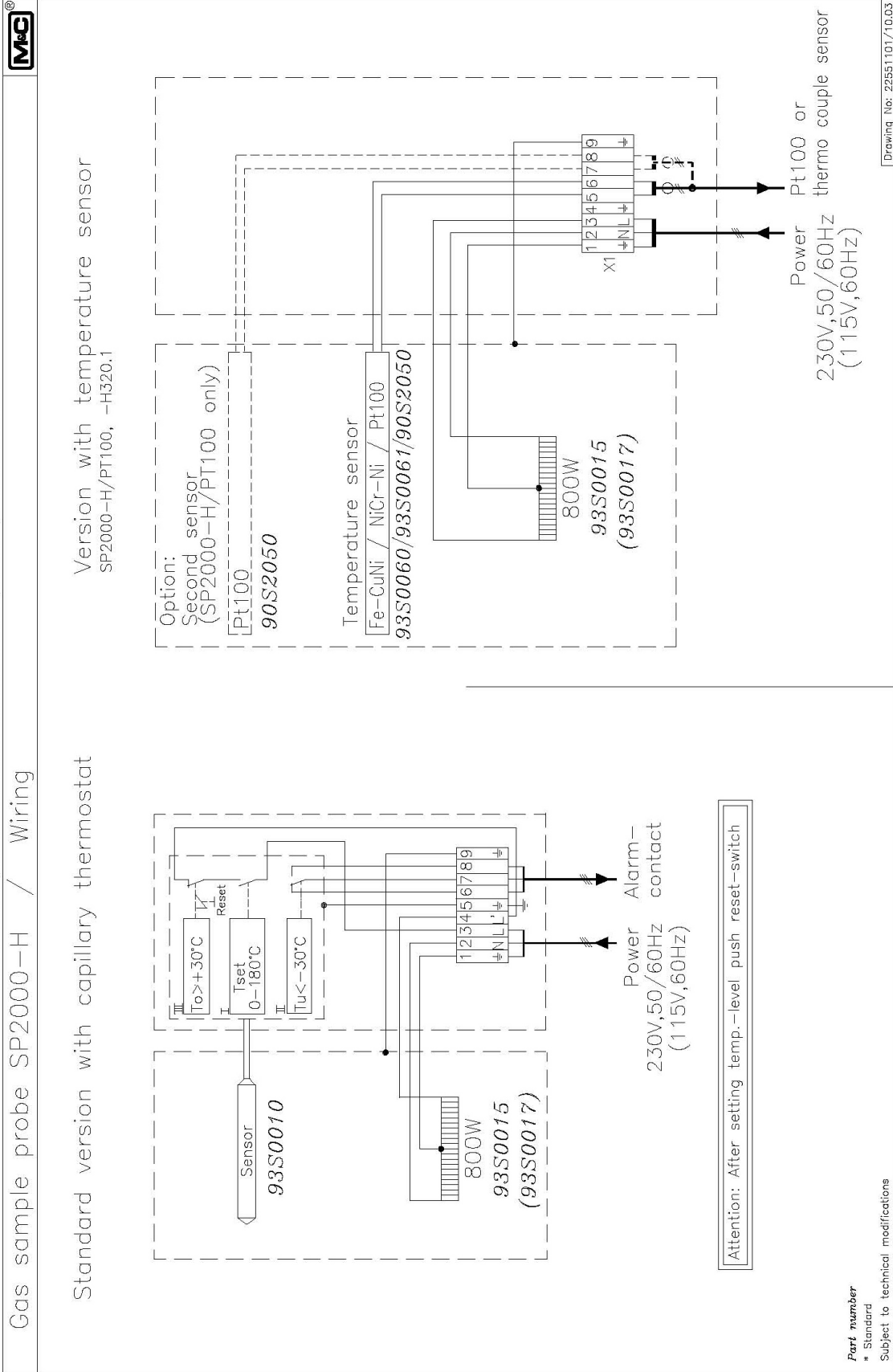

Figure 7 Electrical connexions for SP2020-H.. with thermostate controller

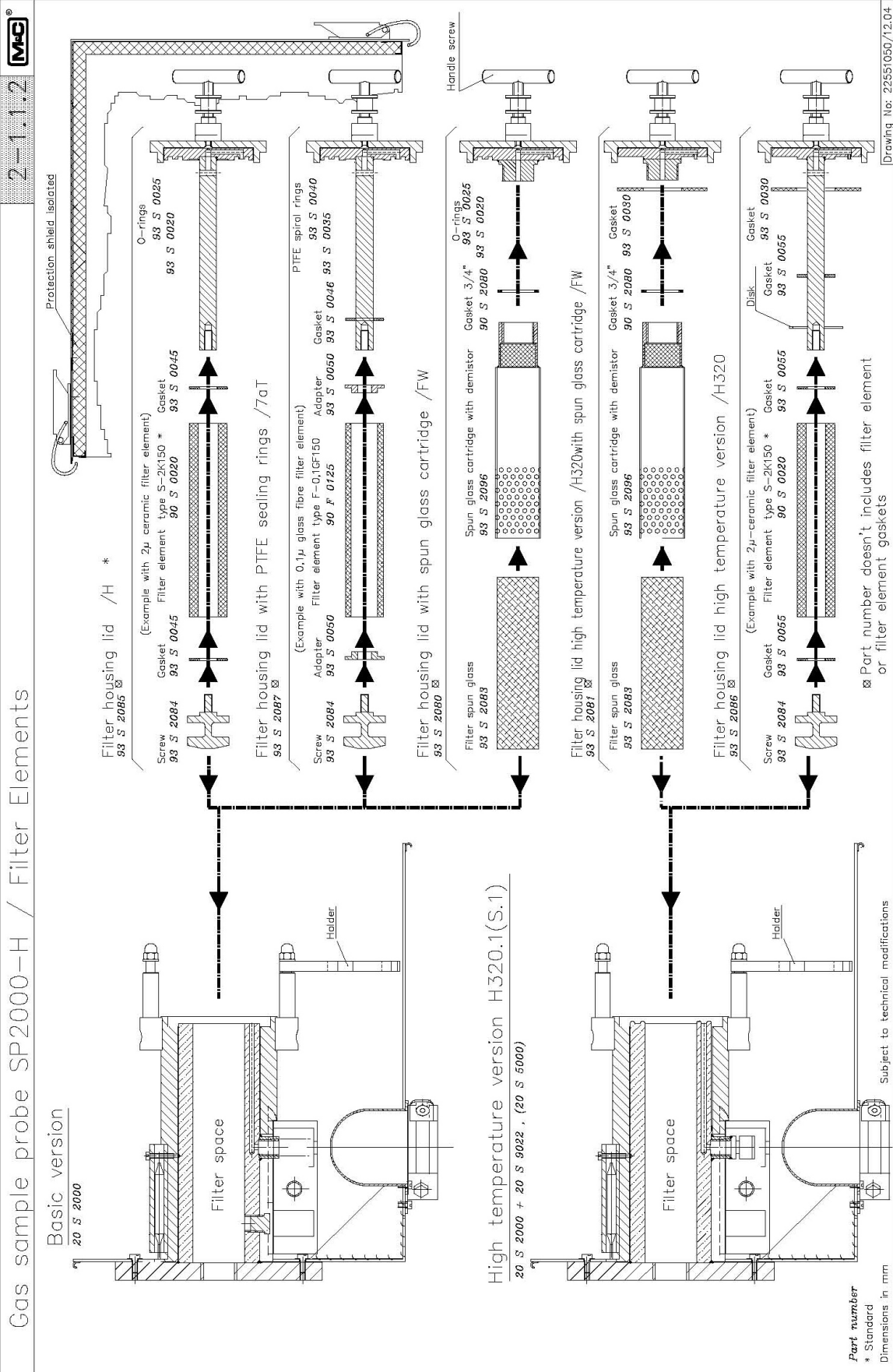

Figure 9 Possible filter elements

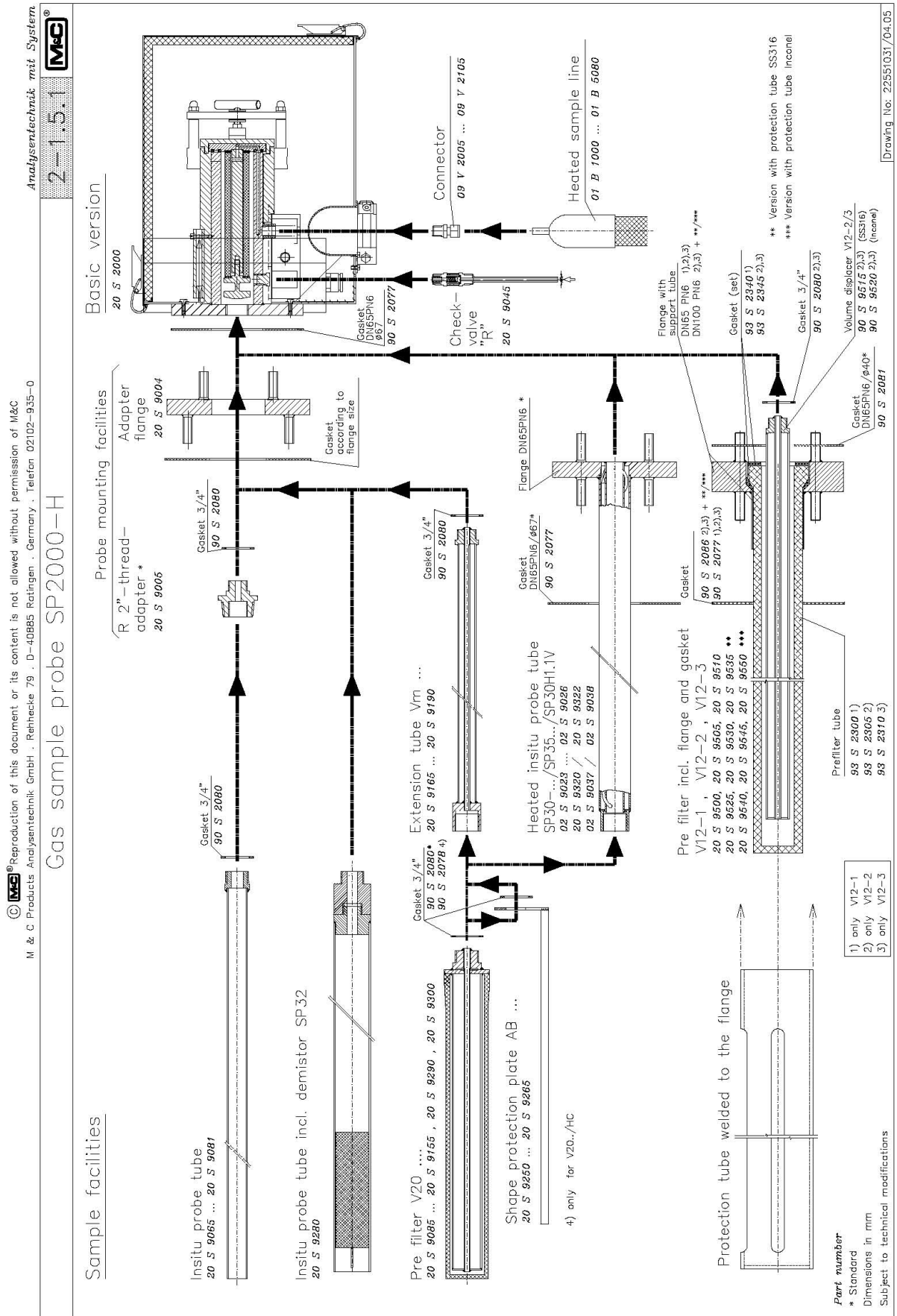
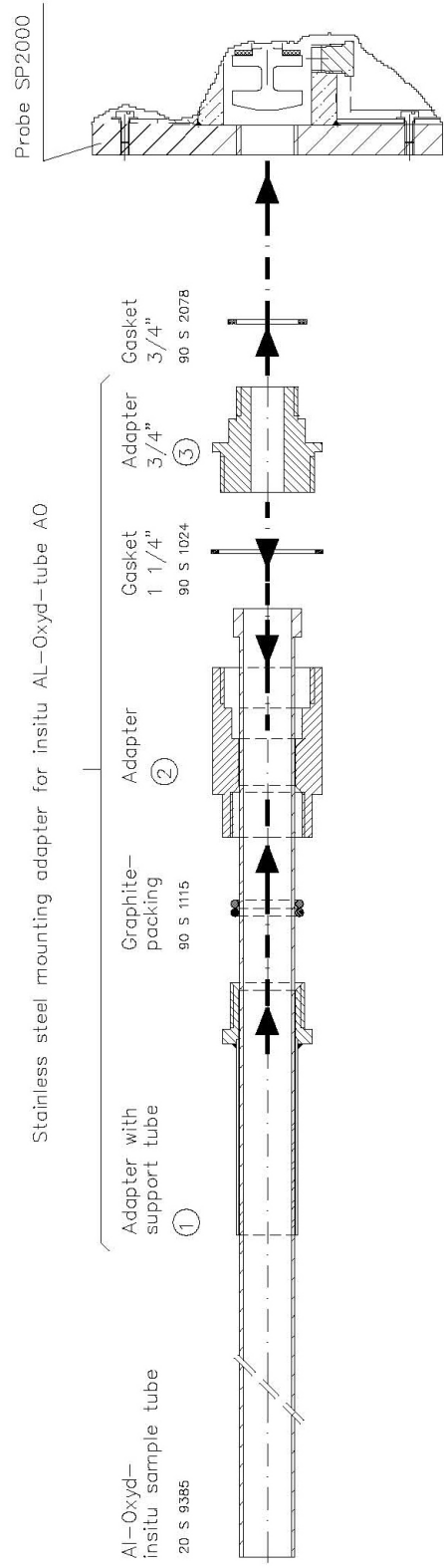

Figure 10 Sample tubes and pre filter

© M&C[®] Reproduction of this document or its content is not allowed without permission of M&C
 M & C Products Analysetechnik GmbH · Rehbecke 79 · D-40885 Ratingen · Germany · Telefon 02102-935-0
 Gas sample probe SP2000-H / High temperature insitu probe max 1800°C
 2-1.6.1



Part number
 Dimensions in mm
 Subject to technical modifications

Drawing No.: 22551046/03.96

Figure 11 High temperature sample tube out of aluminium oxide

Electr. heated sample tube SP30-H1.1/-H2

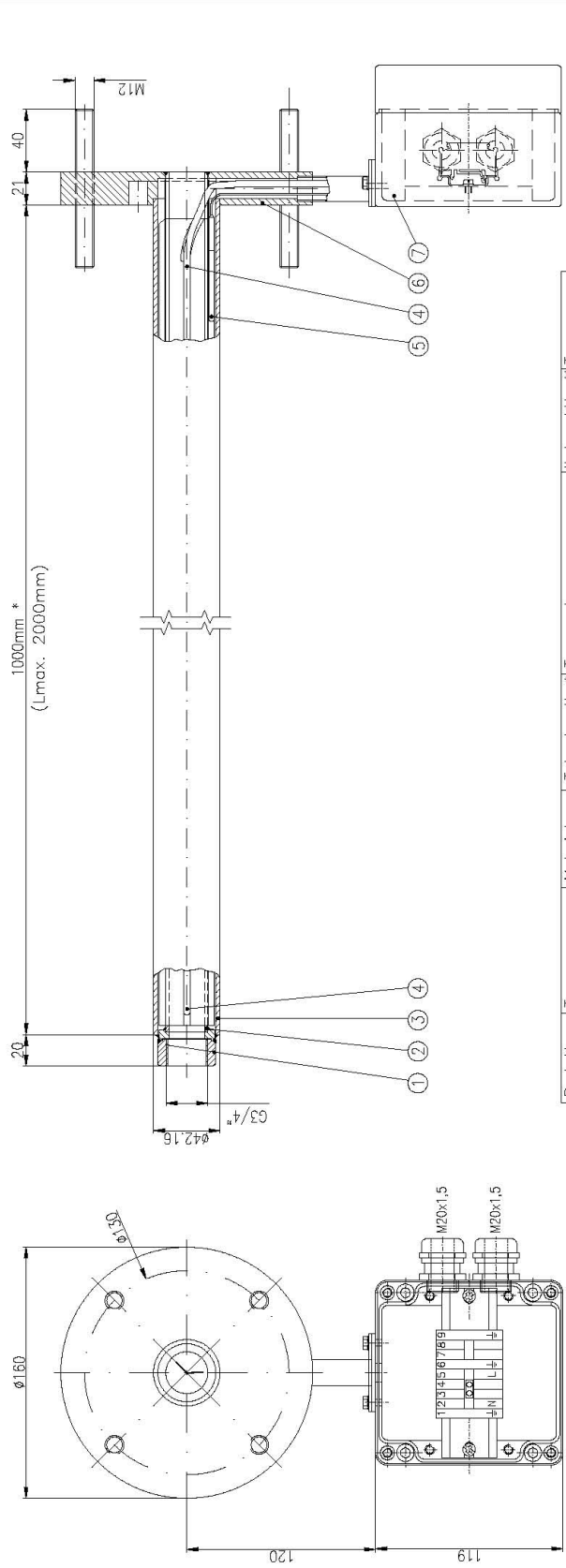

Part No.	Type	Material	Tube length *	Temperature sensor	Heater cartridge **	Temp. max.
02S9023	SP30-H1.1		600mm		2x300W	320°C
02S9025	SP30-H1.1		1000mm		2x400W	320°C
02S9026	SP30-H1.1	1.4539	1500mm	Thermo couple Fe-CuNi	2x600W	320°C
02S9027	SP30-H1.1	1.4539	2000mm	Thermo couple Fe-CuNi	2x600W	320°C
02S9096	SP30-H1.1/HC	1.4539	600mm	Thermo couple Fe-CuNi	2x300W	320°C
02S9092	SP30-H1.1/HC	1.4539	1000mm	Thermo couple Fe-CuNi	2x400W	320°C
02S9094	SP30-H1.1/HC	Hastelloy C	1500mm	Thermo couple Fe-CuNi	2x600W	320°C
02S9099	SP30-H1.1/HC	Hastelloy C	2000mm	Thermo couple Fe-CuNi	2x600W	320°C
02S9023P	SP30-H2	Hastelloy C	600mm	Thermo couple Fe-CuNi	2x300W	200°C
02S9025P	SP30-H2	Hastelloy C	1000mm	Thermo couple Fe-CuNi	2x400W	200°C
02S9026P	SP30-H2	1.4539	1500mm	Thermo couple Fe-CuNi	2x600W	200°C
02S9027P	SP30-H2	1.4539	2000mm	PT100	2x600W	200°C

*Standard		Part No.		Material	
Item	Description	Type	Part-No.	Material	Material
1	Muffe G3/4"				
2	Tube 42.16x2.77				
3	Tube 26.67x2.11				
4	Heater cartridge				
5	Thermo couple				
5.1	Sensor				
6	Flange DN65 PN6				
7	Terminal box				
8		DN65 PN6			
9				Al, painted	
10					
11					
12					

Dimensions in mm
Power 230V/50Hz (115V/60Hz)
Thermo couple/PT100
Power 230V: terminal 3-4
Power 115V: terminal 2-3/4-5

Part No.
Subject to technical modifications

Figure 12 Heated sample tubes SP30..

Solenoid valve unit 2 for gas sample probe SP2000/3VA/MS-B or /MS-C

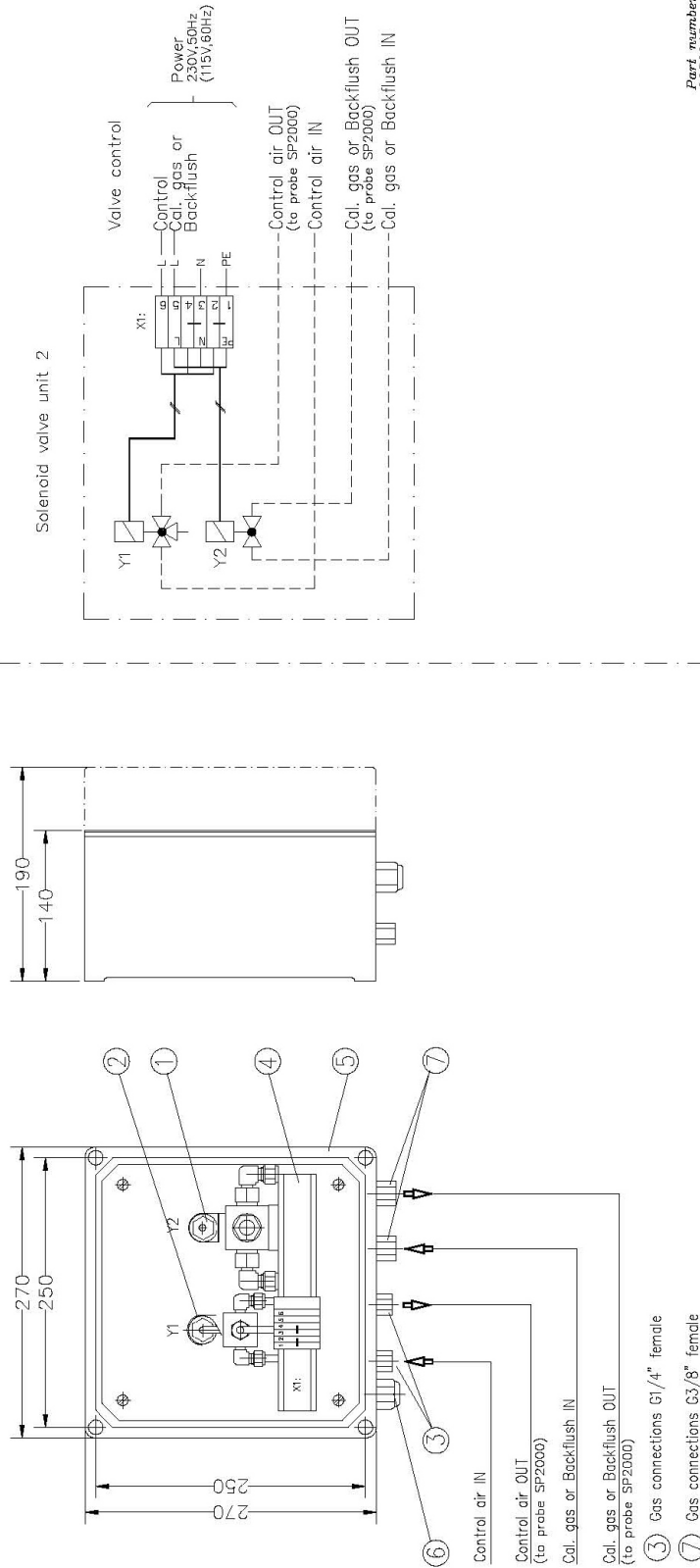

Part number 2059345

Item		Description		Type	Part-No	Material	Subject to technical modifications	
Item	Description	Type	Part-No	Material	Item	Description	Type	Material
8					15			
9					16			
10					17			
11					18			
12					19			
13					20			
14					21			

Drawing No: 22551060/01.03

Figure 13 Solenoid valve unit 2